

1999 Chevrolet Corvette

1998-99 ENGINES 5.7L V8 - Corvette

1998-99 ENGINES

5.7L V8 - Corvette

ENGINE IDENTIFICATION

NOTE: For repair procedures not covered in this article, see **ENGINE OVERHAUL PROCEDURES** article in **GENERAL INFORMATION**.

VEHICLE IDENTIFICATION NUMBER (VIN)

Engine can be identified by eighth character of VIN which is stamped on a metal pad located near lower left corner of windshield. A "G" in eighth character of VIN indicates 5.7L V-8 (LS1). A "W" in tenth character of VIN indicates 1998 model year. A "X" in tenth character of VIN indicates 1999 model year. Engine can also be identified by a 3-character engine code (RPO code). This code may be stamped on engine, at flange where engine and transmission meet.

ADJUSTMENTS

VALVE CLEARANCE ADJUSTMENT

NOTE: Engine is equipped with non-adjustable hydraulic valve lifters.

TROUBLE SHOOTING

NOTE: For trouble shooting engine components, see appropriate table in **TROUBLE SHOOTING** article in **GENERAL INFORMATION**.

REMOVAL & INSTALLATION

WARNING: To avoid injury from accidental air bag deployment, read and carefully follow all **SERVICE PRECAUTIONS** and **DISABLING & ACTIVATING AIR BAG SYSTEM** procedures. For 1998 models, see **AIR BAG DEACTIVATION PROCEDURES** article in **GENERAL INFORMATION**. For 1999 models, see **AIR BAG DEACTIVATION PROCEDURES** article in **GENERAL INFORMATION**.

CAUTION: When battery is disconnected, vehicle computer and memory systems may lose memory data. Driveability problems may exist until computer systems have completed a relearn cycle. For 1998 models, see

COMPUTER RELEARN PROCEDURES - GENERAL MOTORS article in **GENERAL INFORMATION** before disconnecting battery. For 1999 models, see **COMPUTER RELEARN PROCEDURES - GENERAL MOTORS** article in **GENERAL INFORMATION** before disconnecting battery.

NOTE: For reassembly reference, label all electrical connectors, vacuum hoses and fuel lines before removal. Also place mating marks onto engine hood and other major assemblies before removal.

FUEL PRESSURE RELEASE

Disconnect negative battery cable. Loosen fuel tank filler cap. Connect Fuel Gauge (J 34730-1) to fuel pressure connection (wrap shop towel around fitting to avoid spillage). Install bleed hose. Turn gauge valve, and drain fuel into an appropriate container.

COOLING SYSTEM BLEEDING

CAUTION: When removing radiator surge tank fill cap on a hot engine, slowly rotate the cap counterclockwise approximately 1/4 turn. Stop and allow the hissing to stop. After all hissing stops, continue turning counterclockwise to remove the cap.

1. Fill system through radiator surge tank opening up to base of fill neck. Start engine and idle for one minute. Install radiator surge tank cap. Cycle RPM from idle to 3000 in 30 second intervals until engine coolant reaches 210°F (99°C). Shut off engine.
2. Loosen radiator surge tank cap. After all hissing stops, remove cap. Start engine. Idle engine for one minute and fill surge tank to between FULL COLD and FULL HOT. Install radiator surge tank cap. Cycle RPM from idle to 3000 in 30 second intervals until engine coolant reaches 210°F (99°C). Shut off engine. Top off coolant as necessary.

ENGINE

Removal

1. Disconnect negative battery cable. Discharge A/C system using approved refrigerant recovery/recycling equipment. Plug openings. Raise and support vehicle. Drain coolant. Lower vehicle. Disconnect IAT and MAF sensor connectors. Disconnect fuel regulator purge line from air intake duct. Remove air intake duct and air cleaner assembly. Remove accessory drive belt. Remove fuel rail covers. Relieve fuel system pressure. See **FUEL PRESSURE RELEASE** .

NOTE: Cap fittings and plug holes when separating fuel system components in order to prevent leakage and/or dirt and other contaminants from entering fuel system.

2. Disconnect fuel lines at fuel rail. Disconnect radiator and heater hoses from water pump. Disconnect the following electrical connectors:
 - Fuel Injectors
 - Ignition Coil Main Connectors
 - Evaporative Purge Solenoid
 - Electric Throttle Motor
 - Throttle Position Sensor
 - ECT Sensor
 - A/C Compressor
3. Disconnect generator electrical connectors. Remove generator rear bracket bolts and bracket. Remove generator mounting bolts and generator. Disconnect brake booster vacuum hose at brake booster. Remove intermediate shaft-to-steering shaft bolt. Disconnect intermediate steering shaft from steering gear, and wire aside. Disconnect Air Injection Reactor (AIR) hose from left exhaust manifold.

NOTE: DO NOT remove engine flywheel housing-to-driveline support assembly bolts at this time.

4. Raise vehicle. Remove front wheels. Remove intermediate exhaust pipe. Remove close-out panel bolts and panel to access lower engine components. Remove starter electrical connectors. Remove all grounds from right side of engine block. Remove starter bolts and starter. Disconnect oil level sensor connector. Disconnect crank position sensor connector. Disconnect right front HO₂S connector. Remove A/C compressor hose retaining bolt. Remove A/C compressor hose from compressor, and plug openings. Disconnect engine oil temperature sensor connector. Disconnect all grounds from left side of engine block. Disconnect left front HO₂S connector.
5. Remove front stabilizer bar bolts and straps. Disconnect front stabilizer bar from cradle. Disconnect electrical connectors and harness from electric cooling fans. Remove electric cooling fan bolts and cooling fans. Using Spring Compressor (J 33432-A), compress front transverse spring. See **Fig. 1**.
6. Remove tie rod end nuts. Remove tie rod ends from steering knuckles using Ball Joint Separator (J 42188). Disconnect all electrical connectors at cradle. Remove lower shock absorber mounting bolts. Separate lower ball joints using ball joint separator. Remove spring compressor from front transverse spring.

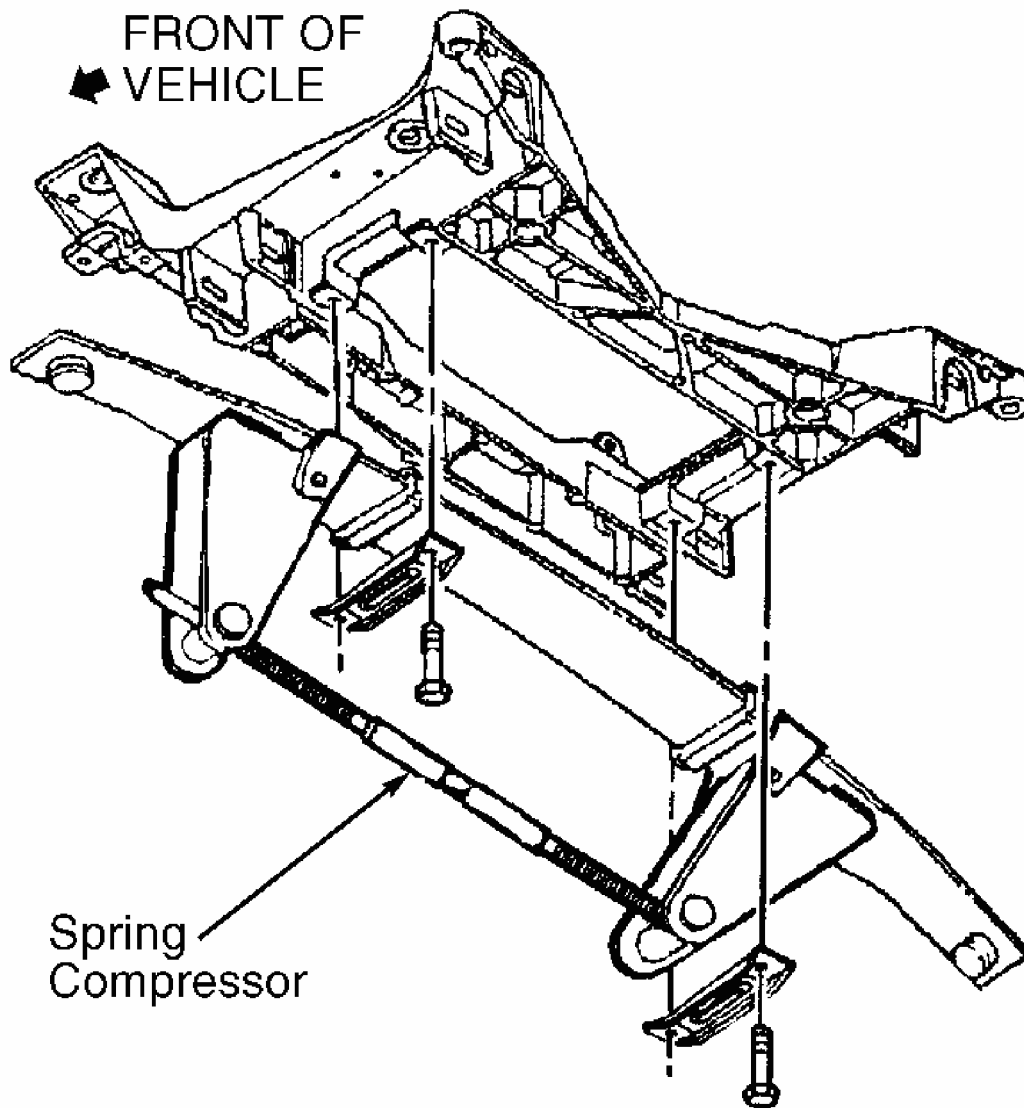

G98E12322

Fig. 1: Compressing Front Transverse Spring.
Courtesy of GENERAL MOTORS CORP.

7. On automatic transmission equipped vehicles, disconnect automatic transmission cooler lines at engine flywheel housing junction and at radiator. Remove the 2 plugs in driveline support assembly. See **Fig. 2** . Install a 55 millimeter or longer 10 X 1.5 bolt in each location. Tighten bearing support bolts to 26 ft. lbs. (35 N.m). Remove engine flywheel housing access plug. Rotate flywheel hub collar to access bolt, and loosen bolt. See **Fig. 3** .

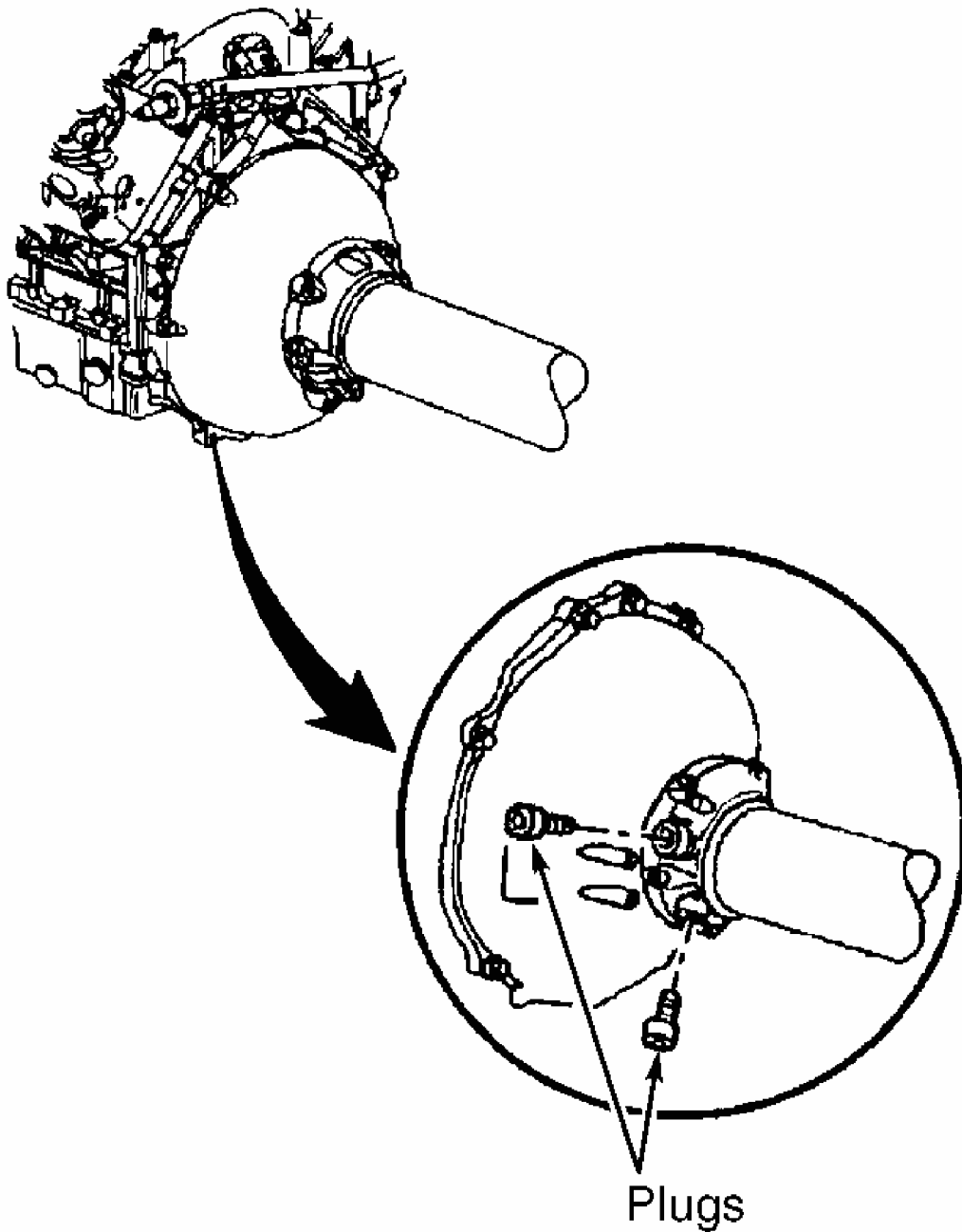

G98F12323

Fig. 2: Identifying The 2 Plugs In Driveline Support Assembly.
Courtesy of GENERAL MOTORS CORP.

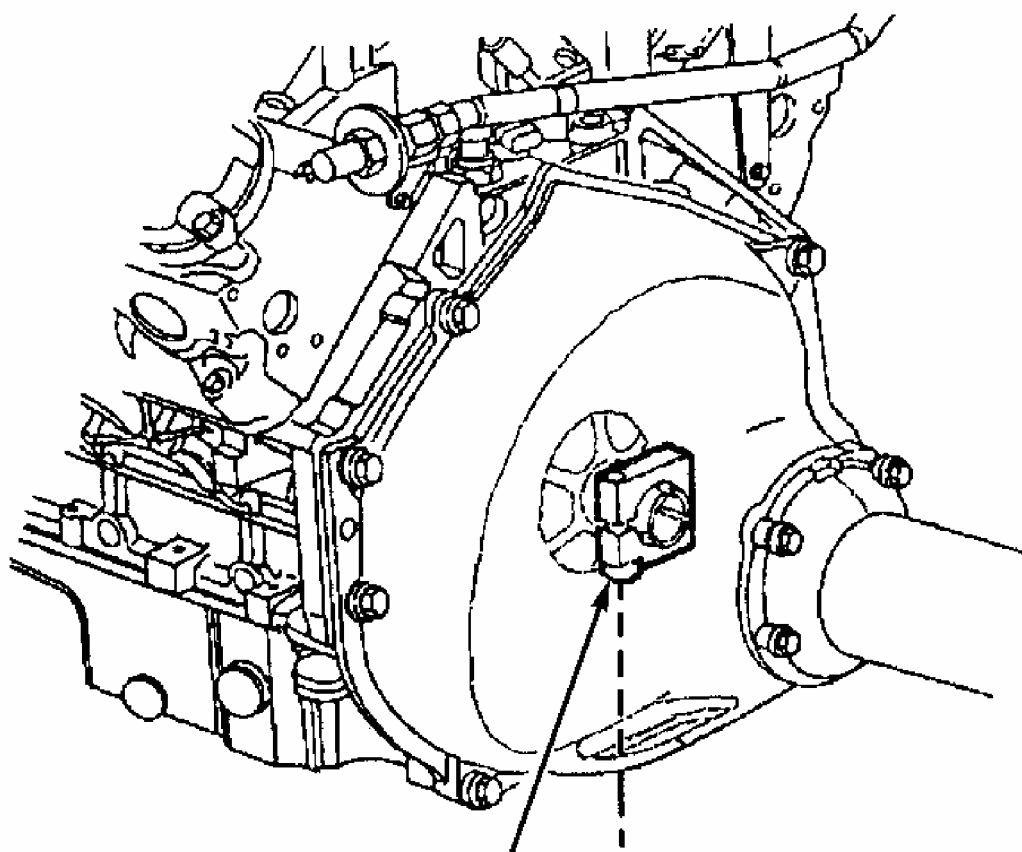

Flywheel
Hub Collar Bolt

G98G12324

Fig. 3: Loosening Flywheel Hub Collar Bolt.
Courtesy of GENERAL MOTORS CORP.

8. On all models, install Driveline Support (J 42203) to close-out panel flange. Partially lower vehicle. Support engine and front cradle on Engine Support Table (J 39580). Remove front cradle nuts. Partially lower engine and cradle.
9. Label and disconnect the following electrical connectors:
 - Engine Oil Pressure Gauge
 - Camshaft Position Sensor
 - MAP Sensor
 - Knock Sensor
 - Ground On Rear Of Left Head
 - All Remaining Electrical Connections

1999 Chevrolet Corvette

1998-99 ENGINES 5.7L V8 - Corvette

10. Remove front driveline support assembly bolts. Slide engine and cradle assembly forward to clear drive shaft splines. Raise vehicle completely off of engine and cradle assembly.

NOTE: It is not necessary to open power steering system during engine removal.

11. Remove P/S pump and reservoir and wire to cradle. Remove engine mount-to-cradle nuts. Remove engine from cradle.

Installation

To install, reverse removal procedure. Fill crankcase. Fill and bleed cooling system. See **COOLING SYSTEM BLEEDING** . Evacuate and recharge A/C system. On automatic transmission equipped vehicles, leave flywheel hub collar bolt out on initial start-up. Idle or drive vehicle for at least 10 minutes. Look for coolant or oil leaks. Shut off engine and allow to cool to room temperature. Install hub collar bolt and tighten to 96 ft. lbs. (130 N.m).

INTAKE MANIFOLD

NOTE: Ensure injector connectors are marked for installation reference prior to removal. Performance and emissions will be affected if injector connectors are not positioned correctly.

Removal

1. Disconnect negative battery cable. Drain cooling system. Disconnect IAT and MAF sensor connectors. Disconnect fuel regulator purge line from air intake duct. Remove air intake duct and air cleaner assembly.
2. Remove fuel rail covers. Relieve fuel pressure. See **FUEL PRESSURE RELEASE** . Disconnect fuel lines from fuel rail. Remove vacuum and crankcase vent hoses. Remove throttle body coolant outlet hose from throttle body. Disconnect fuel injector connectors. Label and disconnect all remaining electrical connectors. Remove intake manifold bolts. Remove intake manifold.

Installation

To install, reverse removal procedure. Tighten bolts to specification. See **TORQUE SPECIFICATIONS** . See **Fig. 4** . Fill and bleed cooling system. See **COOLING SYSTEM BLEEDING** .

1999 Chevrolet Corvette

1998-99 ENGINES 5.7L V8 - Corvette

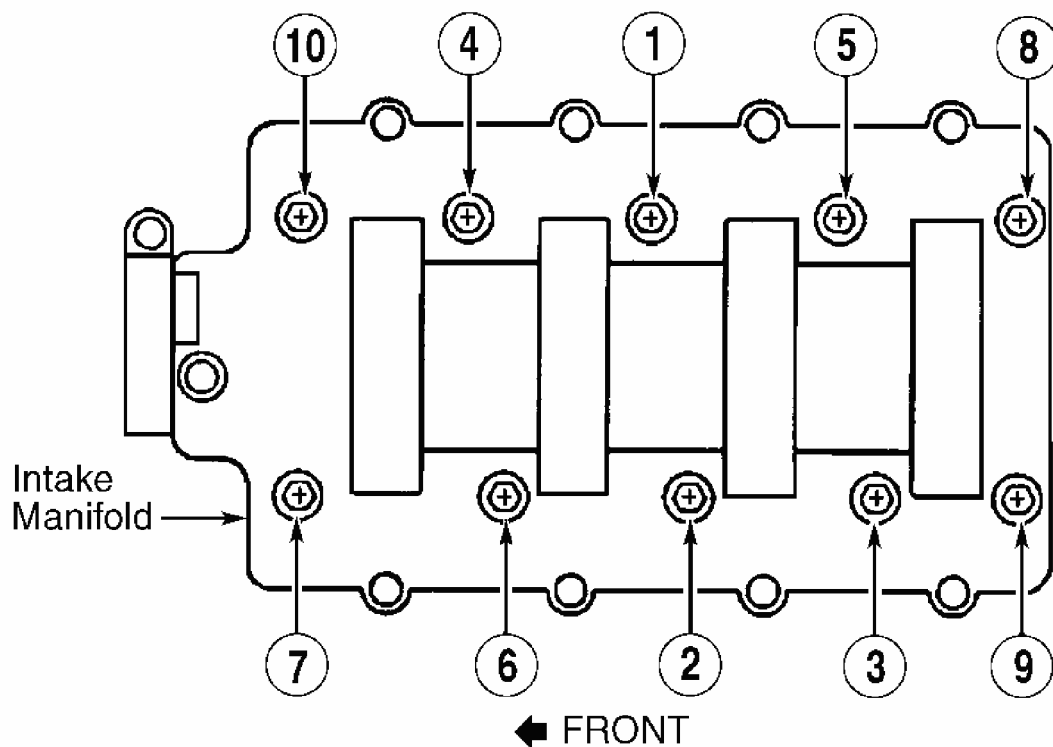

G97C03684

Fig. 4: Intake Manifold Bolt Tightening Sequence
Courtesy of GENERAL MOTORS CORP.

EXHAUST MANIFOLD

Removal (Left)

1. Disconnect negative battery cable. Raise and support vehicle. Remove left side intermediate pipe flange nuts from exhaust manifold studs. Remove oxygen sensor. Lower vehicle. Remove left side fuel rail cover. Relieve fuel pressure. See **FUEL PRESSURE RELEASE**. Disconnect fuel lines from fuel rail. Remove the generator rear bracket and bolts. Disconnect generator and coolant temperature sensor connectors.
2. Remove drive belt. Remove generator mounting bolts and generator. Remove air injection hose at air injection pipe. Remove air injection pipe bolts and gaskets from exhaust manifold, and position pipe aside. Remove spark plug wires from spark plugs and coils. Remove spark plugs. Remove No. 5 coil bolts, and position coil aside. Remove exhaust manifold bolts, exhaust manifold and gasket.

Removal (Right)

Raise and support vehicle. Remove flange nuts from exhaust manifold studs. Disconnect

1999 Chevrolet Corvette

1998-99 ENGINES 5.7L V8 - Corvette

oxygen sensor. Lower vehicle. Remove air injection pipe bracket bolt from rear of left cylinder head. Remove air injection pipe (with check valve) from right exhaust manifold. Remove spark plug wires at spark plugs. Remove exhaust manifold bolts, exhaust manifold and gasket.

Installation (Left & Right)

1. To install exhaust manifold(s), reverse removal procedure. Apply sealant to bolt threads.

NOTE: DO NOT apply sealant to the first 3 threads of the exhaust manifold bolts. Apply a 1/4 inch wide band of Threadlock (12345493) or equivalent to bolt threads.

2. Tighten nuts and bolts to specification. See TORQUE SPECIFICATIONS table.

VAPOR VENT PIPE

Removal & Installation

Remove intake manifold. See INTAKE MANIFOLD . Disconnect knock sensor wire harness retaining clips and position harness aside. Remove vapor vent pipe bolts, vent pipe and gaskets. To install, reverse removal procedure.

ENGINE VALLEY COVER

Removal & Installation

Remove intake manifold. See INTAKE MANIFOLD . Remove vapor vent pipe. See VAPOR VENT PIPE . Unplug knock sensor connectors, and position knock sensor harness aside. Remove engine valley cover bolts and valley cover. To install, reverse removal procedure.

CYLINDER HEADS

CAUTION: Remove cylinder head when engine is completely cold.

Removal (Right)

1. Disconnect negative battery cable. Remove intake manifold, exhaust manifold and valve cover. See INTAKE MANIFOLD , EXHAUST MANIFOLD and VALVE COVERS .
2. Remove rocker arms, and pushrods. See ROCKER ARMS & PUSHRODS. Remove vapor vent pipe. See VAPOR VENT PIPE . Remove cylinder head bolts and cylinder head.

1999 Chevrolet Corvette

1998-99 ENGINES 5.7L V8 - Corvette

Removal (Left)

1. Disconnect negative battery cable. Remove intake manifold, exhaust manifold and valve cover. See procedures in **INTAKE MANIFOLD** , **EXHAUST MANIFOLD** and **VALVE COVERS** .
2. Remove rocker arms, and pushrods. See **ROCKER ARMS & PUSHRODS** . Remove vapor vent pipe. See **VAPOR VENT PIPE** . Remove ground wires and bolts from rear of head. Remove power steering pump pulley using Pump Pulley Remover (J 25034-B). Remove power steering pump mounting bolts.
3. Remove power steering pump assembly, and set aside. Remove power steering pump mounting bracket bolts and bracket. Remove cylinder head bolts and cylinder head.

Inspection

See **CYLINDER HEAD** under OVERHAUL.

Installation

1. Clean cylinder head bolt holes and threads. DO NOT coat composition-type head gaskets with sealer. Install head gasket onto cylinder block. Install cylinder head.

CAUTION: DO NOT reuse the M11 cylinder head bolts. Install NEW M11 cylinder head bolts during reassembly. See Fig. 5 .

2. Install NEW M11 cylinder head bolts. Apply a 1/4 inch band of Threadlock (12345493) to threads of the M8 cylinder head bolts. Tighten M11 bolts to 22 ft. lbs. in sequence. Tighten M11 bolts an additional 76 degrees in sequence. Tighten M11 bolts 1-8 an additional 76 degrees in sequence, and M11 bolts 9 and 10 an additional 34 degrees. Tighten M8 bolts 11-15 in sequence to 22 ft. lbs. See **Fig. 5** . To complete installation, reverse removal procedure. See **TORQUE SPECIFICATIONS** . Fill and bleed cooling system. See **COOLING SYSTEM BLEEDING** .

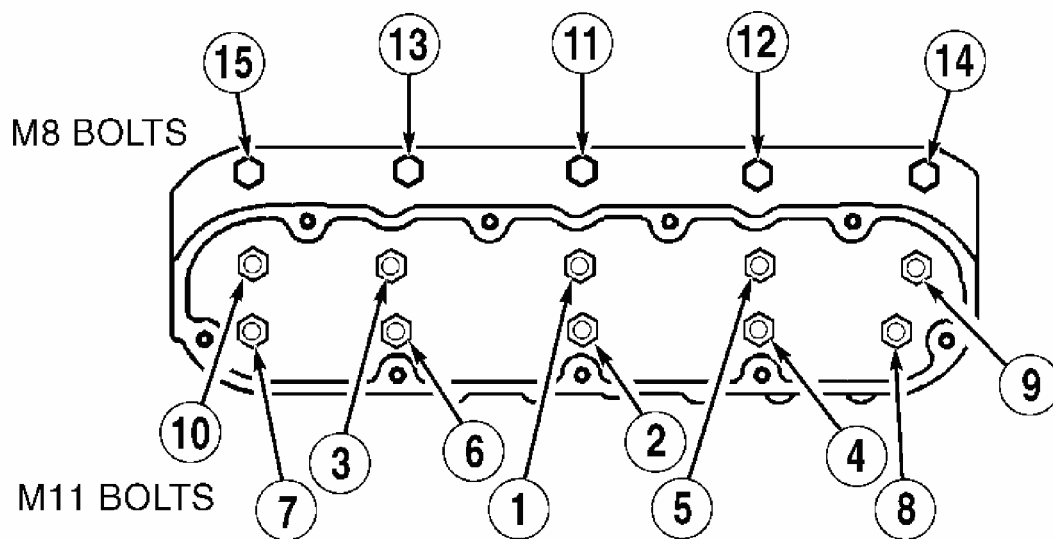

G97H03686

Fig. 5: Cylinder Head Bolt Tightening Sequence
 Courtesy of GENERAL MOTORS CORP.

CRANKSHAFT FRONT OIL SEAL

NOTE: Front oil seal can be replaced without removing front cover.

Removal

1. Disconnect negative battery cable. Release accessory drive belt tensioner. Remove drive belt. Remove rack and pinion assembly. See appropriate POWER RACK & PINION article in STEERING. Remove starter. Remove power steering cooler from front crossmember, and position aside.
2. Release A/C belt tensioner, and remove belt. Note position of crankshaft balancer before removal. Mark or scribe end of balancer and crankshaft for proper re-installation. Remove crankshaft balancer. Carefully pry seal from timing cover.

Installation

Install front oil seal into timing cover using Front Cover Seal Installer (J 41478). See **Fig. 6**. Reverse removal procedure.

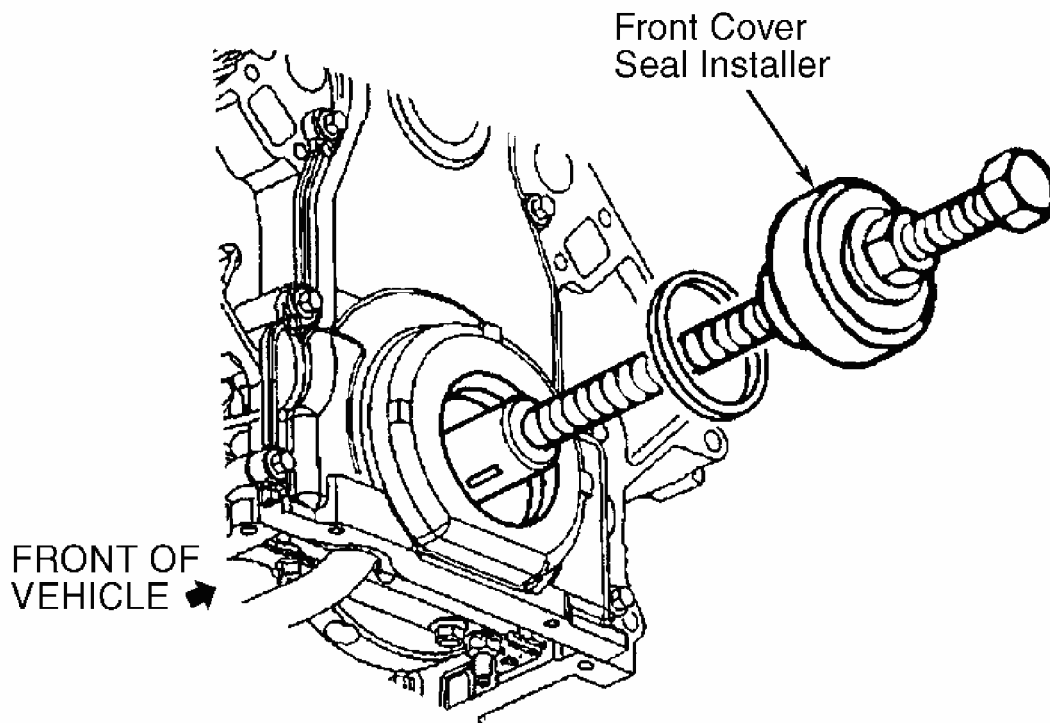

G98112326

Fig. 6: Installing Timing Cover Oil Seal
Courtesy of GENERAL MOTORS CORP.

FRONT COVER

Removal

Disconnect fuel regulator purge line from air intake duct. Remove air intake duct and air cleaner assembly. Drain coolant. Remove water pump. See **WATER PUMP** . Note position of crankshaft balancer before removal. Mark or scribe end of balancer and crankshaft for proper reinstallation. Remove crankshaft balancer. Loosen oil pan bolts. Remove front cover bolts, front cover and gasket.

Installation

1. Apply a 1/4 inch bead of Sealer (12378190) to corners where oil pan meets block. Install front cover, leaving bolts finger tight.

NOTE: Align tapered legs of Front/Rear Cover Alignment Tool (J 41476) with machined alignment surfaces on front cover. See Fig. 7 .

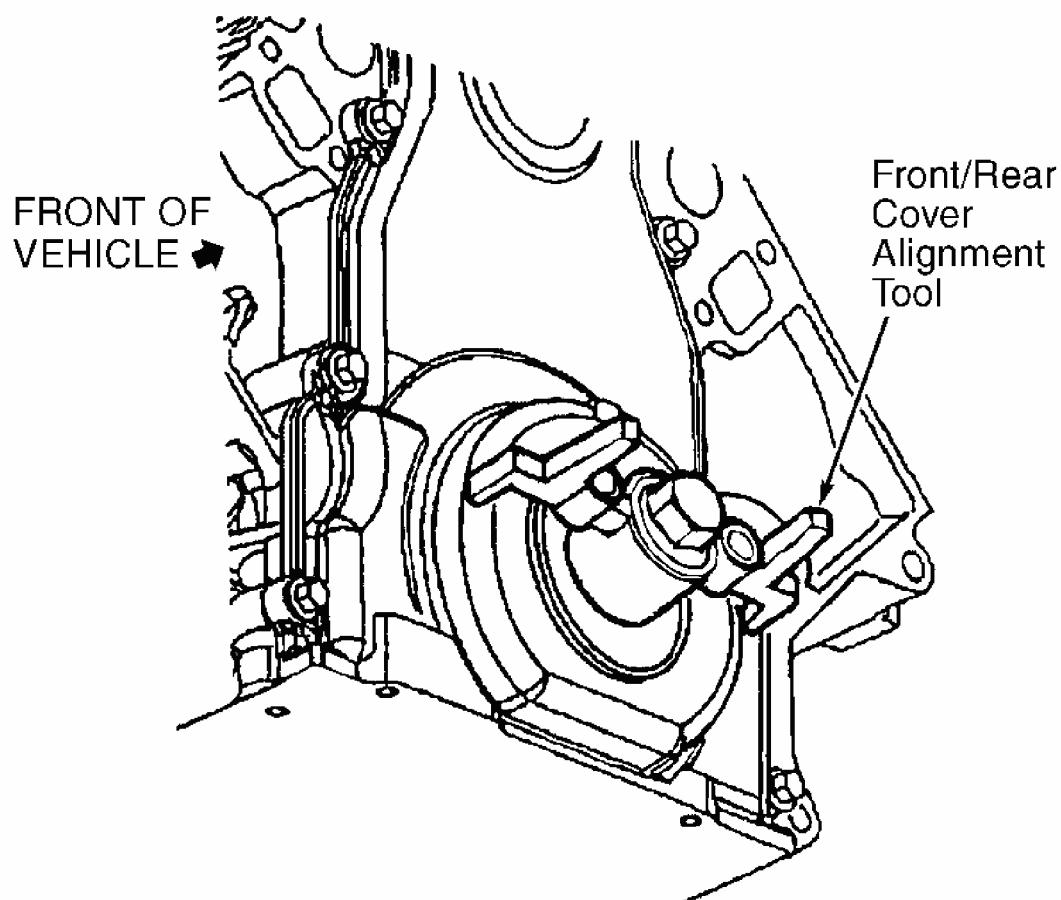

G98J12327

Fig. 7: Installing Front Cover & Alignment Tool
 Courtesy of GENERAL MOTORS CORP.

2. Install Front/Rear Cover Alignment Tool (J 41476) onto front of crankshaft. Install and hand tighten crankshaft balancer bolt. Tighten front cover bolts. Tighten oil pan-to-front cover and oil pan-to-block bolts. Tighten oil pan-to-rear cover bolts. See **TORQUE SPECIFICATIONS** . Remove tool from front of crankshaft. Install NEW front seal into cover using Front Crankshaft Oil Seal Installer (J 41478). To complete installation, reverse removal procedure. Fill crankcase. Fill and bleed cooling system. See **COOLING SYSTEM BLEEDING** .

CRANKSHAFT REAR OIL SEAL

NOTE: Rear oil seal can be replaced without removing rear oil seal cover.

Removal

Remove transmission. For A/T, see appropriate TRANSMISSION REMOVAL & INSTALLATION article in TRANSMISSION SERVICING. For M/T, see appropriate article in CLUTCHES. Note position of flywheel before removal. Mark or scribe end of flywheel for proper reinstallation. Remove flywheel. Remove rear crankshaft oil seal and discard.

Installation

Install rear seal using Rear Seal Installer (J 41479). See **Fig. 8** . Reinstall flywheel and transmission. Tighten bolts to specification. See **TORQUE SPECIFICATIONS** .

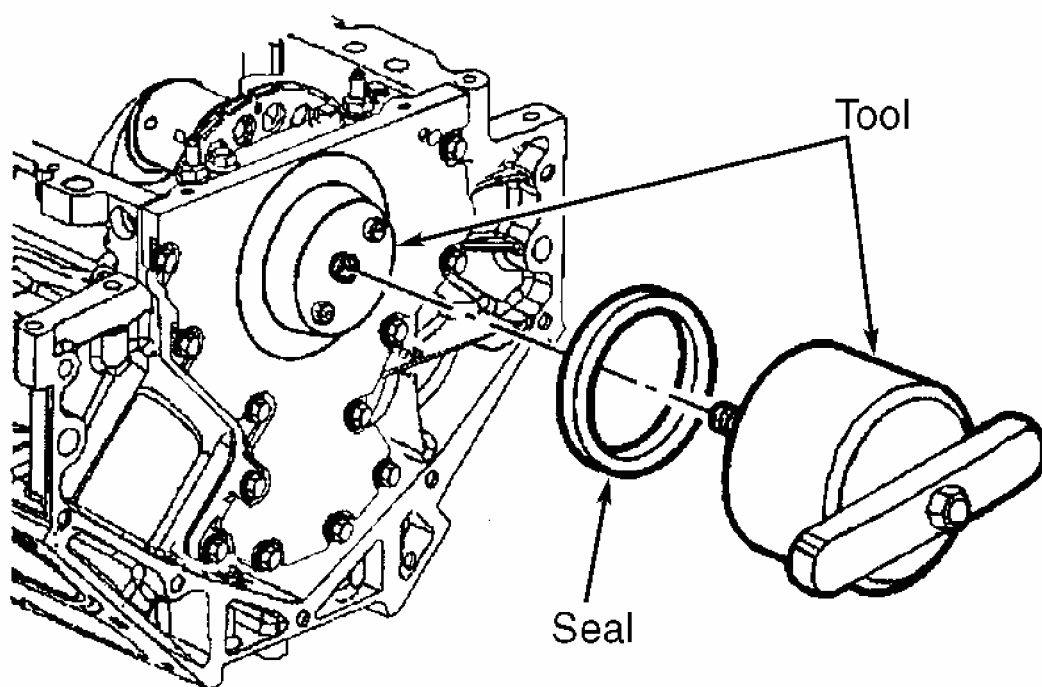

G97F03690

Fig. 8: Installing Crankshaft Rear Oil Seal.
Courtesy of GENERAL MOTORS CORP.

REAR COVER

Removal

Remove transmission and flywheel. See **CRANKSHAFT REAR OIL SEAL** . Remove rear cover-to-block bolts. Loosen oil pan bolts. Remove rear cover and gasket. Remove rear seal from cover, and discard.

Installation

1999 Chevrolet Corvette

1998-99 ENGINES 5.7L V8 - Corvette

1. Apply a 1/4 inch bead of Sealer (12378190) to corners where oil pan meets block. Install rear cover and NEW gasket, leaving bolts finger tight. Rotate the crankshaft until the 2 opposing flywheel bolts are parallel to oil pan surface. See **Fig. 9** .
2. Install Front/Rear Cover Alignment Tool (J 41476) onto rear of crankshaft. Tighten tool retaining bolts until snug. Tighten rear cover-to-block bolts to 18 ft. lbs. (25 N.m). Tighten oil pan-to-rear cover bolts to 106 INCH lbs. (12 N.m). Tighten oil pan-to-front cover and oil pan-to-block bolts to 18 ft. lbs. (25 N.m). Remove front/rear cover alignment tool from crankshaft. Install NEW rear seal using Rear Oil Seal Installer (J 41479). Reinstall flywheel and transmission. Tighten bolts to specification. See **TORQUE SPECIFICATIONS** .

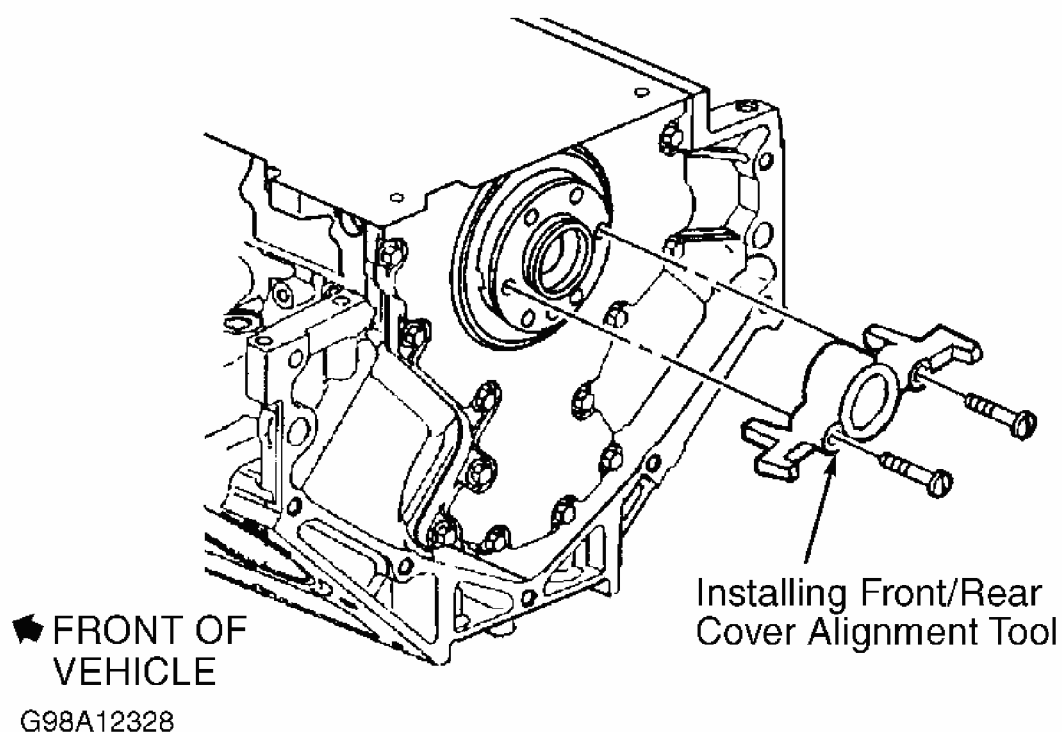

Fig. 9: Installing Front/Rear Cover Alignment Tool
Courtesy of GENERAL MOTORS CORP.

TIMING CHAIN

Removal & Installation

1. Disconnect negative battery cable. Remove crankshaft balancer and front cover. See **FRONT COVER** . Remove oil pan. See **OIL PAN** . Remove oil pump. Rotate crankshaft until camshaft sprocket and crankshaft sprocket timing marks line up with shaft centers. See **Fig. 10** .

2. Remove timing chain and camshaft sprocket. If replacing crankshaft sprocket, use Sprocket Remover (J 41558), and Sprocket Installer (J 41665). Ensure timing marks on crankshaft sprocket and camshaft sprocket are as close together as possible, and lined up with shaft centers.
3. To complete installation, reverse removal procedure. Fill crankcase. Fill and bleed cooling system. See **COOLING SYSTEM BLEEDING** .

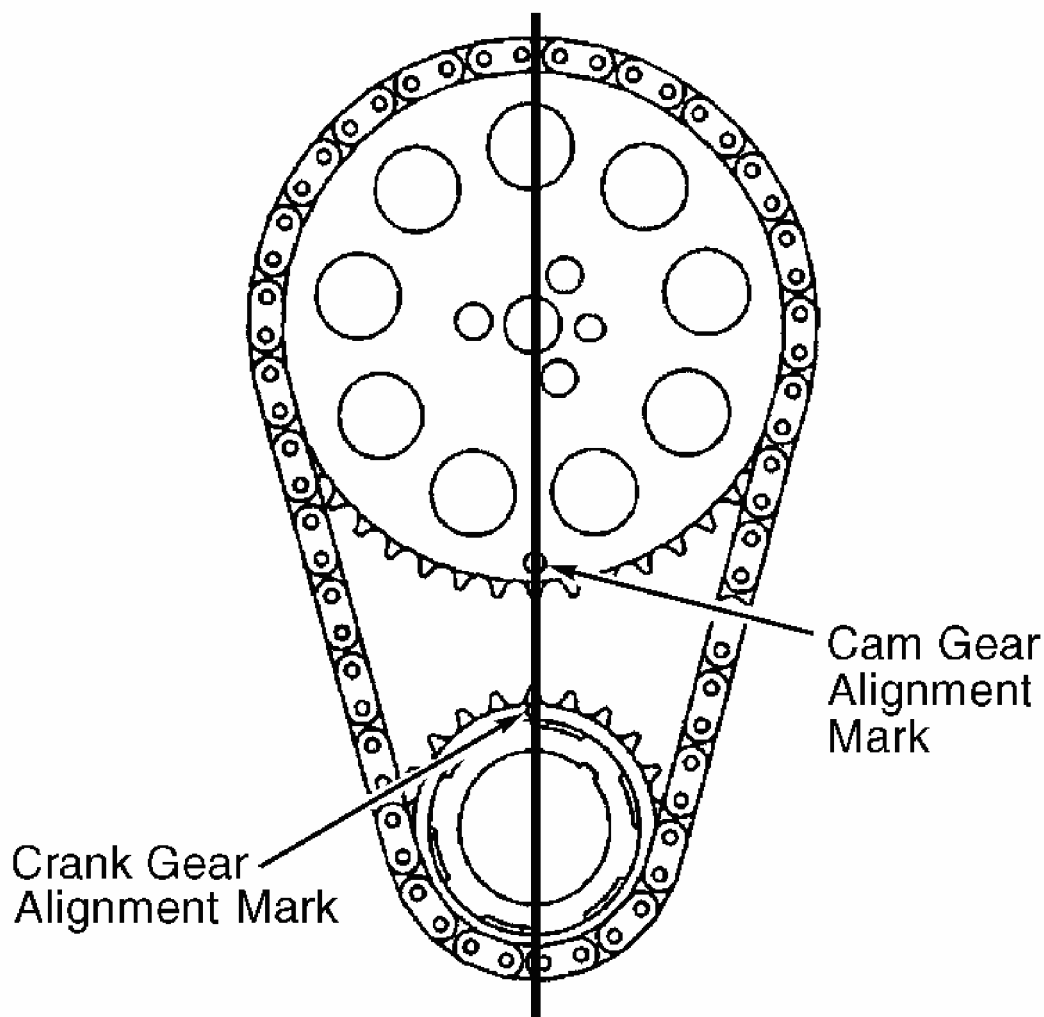

G98B12329

Fig. 10: Identifying Timing Chain Alignment Marks
Courtesy of GENERAL MOTORS CORP.

VALVE COVERS

Removal (Left)

1999 Chevrolet Corvette

1998-99 ENGINES 5.7L V8 - Corvette

1. Disconnect negative battery cable. Remove left side fuel rail cover (if equipped). Relieve fuel pressure. See **FUEL PRESSURE RELEASE** . Disconnect fuel lines from fuel rail. Disconnect generator and coolant temperature sensor connectors. Disconnect brake booster hose from brake booster. Disconnect PCV hose from valve cover. Remove spark plug wires at coils. Disconnect ignition coil main connector. Disconnect any interfering air injection hoses.
2. Remove generator rear bracket and bolts. Disconnect pipes from EVAP purge solenoid. Remove purge solenoid from intake manifold. Remove valve cover bolts, valve cover and gasket.

Removal (Right)

Disconnect negative battery cable. Remove right side fuel rail cover (if equipped). Remove crankcase vent hose. Remove air injection pipe (with check valve) from exhaust manifold (if equipped). Disconnect ignition coil harness main connector. Remove spark plug wires from ignition coils. Remove valve cover bolts, valve cover and gasket.

Installation

To install, reverse removal procedure. Tighten bolts and nuts to specification. See **TORQUE SPECIFICATIONS** .

ROCKER ARMS & PUSH RODS

Removal

Remove valve covers. See **VALVE COVERS** . Mark components for installation in original locations. Remove rocker arm bolts, rocker arms, rocker arm pivot support and push rods.

Installation

1. Lubricate rocker arms and pushrods with clean engine oil. Lubricate flange of rocker arm bolt and any contacting surfaces. Install rocker arm pivot support. Install pushrods, making sure they seat properly into lifter sockets. Install rocker arms and bolts. **DO NOT** fully tighten bolts at this time.

CAUTION: Rocker arm bolts must be tightened to specification with appropriate piston at TDC of compression stroke to avoid damage to valve train.

2. Rotate crankshaft so No. 1 cylinder is at TDC of compression stroke. Tighten rocker arms in order listed. See **ROCKER ARM TIGHTENING SEQUENCE** table. Tighten to specification. See **TORQUE SPECIFICATIONS** table.
3. Rotate crankshaft so No. 6 cylinder is at TDC of compression stroke. Tighten appropriate rocker arms. To complete installation, reverse removal procedure. Tighten

1999 Chevrolet Corvette

1998-99 ENGINES 5.7L V8 - Corvette

bolts and nuts to specification. See **TORQUE SPECIFICATIONS** table.

ROCKER ARM TIGHTENING SEQUENCE

Application	Cylinders No.
Cylinder No. 1 ⁽¹⁾	
Exhaust	1, 2, 7 & 8
Intake	1, 3, 4 & 5
Cylinder No. 6 ⁽¹⁾	
Exhaust	3, 4, 5 & 6
Intake	2, 6, 7 & 8
(1) Piston at TDC of compression stroke.	

CAMSHAFT

NOTE: It is necessary to remove the cylinder heads on this engine for lifter removal.

WARNING: Rotate crankshaft in direction of normal operation only.

Removal

1. Remove valve covers and rocker arms. DO NOT remove push rods. Keep components in order for installation reference. See **VALVE COVERS** and **ROCKER ARMS & PUSH RODS** . Measure lobe lift of camshaft with push rods installed.
2. To measure lobe lift, attach dial indicator to cylinder head. Position indicator pointer onto tip of a push rod. Rotate crankshaft until push rod is at lowest point. Zero indicator. Rotate crankshaft until push rod is at highest point. Record reading, and repeat procedure for remaining lobes.
3. Remove cylinder heads. See **CYLINDER HEADS** . Remove oil pan. See **OIL PAN** . Remove front cover, oil pump and timing chain. See **TIMING CHAIN** . Remove camshaft retaining plate. Remove lifter guide bolts. Remove lifter guide and valve lifters. Using three 5/16" x 18 x 4" bolts as a handle, carefully pull camshaft from engine.

Inspection

Check camshaft for scratches, pits and loose fit in bearings. Check camshaft journal diameter and lobe lift (recorded earlier). Replace camshaft if damaged, or not to specification. See **CAMSHAFT SPECIFICATIONS** table under ENGINE SPECIFICATIONS. If replacing camshaft, replace lifters.

1999 Chevrolet Corvette

1998-99 ENGINES 5.7L V8 - Corvette

Installation

Apply Camshaft Prelube (1052365) to camshaft lobes. Apply engine oil to bearings and camshaft bearing journals. Change engine oil and filter. To complete installation, reverse removal procedure. Tighten bolts and nuts to specification. See **TORQUE SPECIFICATIONS** table. Fill and bleed cooling system. See **COOLING SYSTEM BLEEDING** .

WATER PUMP

Removal

Disconnect negative battery cable. Disconnect IAT and MAF sensor connectors. Remove fuel regulator purge line from air intake duct. Remove air intake duct. Remove air cleaner assembly. Remove accessory drive belts. Drain coolant. Disconnect radiator and heater hoses at water pump. Remove water pump pulley. Remove water pump bolts, water pump and gasket.

Installation

To install, reverse removal procedure. Use NEW gasket. Fill and bleed cooling system. See **COOLING SYSTEM BLEEDING** . Tighten bolts and nuts to specification. See **TORQUE SPECIFICATIONS** table.

OIL PAN

CAUTION: Alignment of oil pan is critical. Oil pan has mounting points for transmission bellhousing. It is important that oil pan and rear of block/rear seal cover are flush, and that rear of oil pan does not protrude beyond engine block.

Removal

1. Disconnect negative battery cable. Remove generator from mounting bracket, and wire aside. Support engine using Engine Support Fixture (J 41803). Raise and support vehicle. Remove front wheels. Remove tie rod end nuts. Remove tie rod ends from steering knuckles using Ball Joint Separator (J 42188).
2. Remove front stabilizer bar bolts and straps. Disconnect front stabilizer bar from cradle. Remove P/S cooler bolts from cradle. Disconnect P/S cooler from cradle, and wire aside. Remove P/S gear bolts. Remove P/S gear from cradle, and wire aside.
3. Using Spring Compressor (J 33432-A), compress front transverse spring. See **Fig. 1** . Remove lower shock absorber bolts. Remove lower ball joint nuts. Separate lower ball joints using ball joint separator. Remove spring compressor from front spring. Disconnect all electrical wiring from crossmember. Remove motor mount-to-crossmember bolts. Support crossmember with a transmission jack. Remove

1999 Chevrolet Corvette

1998-99 ENGINES 5.7L V8 - Corvette

crossmember bolts and crossmember.

4. Drain crankcase. Remove oil filter. Remove A/T cooler line bracket bolts (if equipped). Remove flywheel housing-to-oil pan bolts. Remove flywheel housing cover bolts. Disconnect oil level sensor and remove. Disconnect engine oil temperature sensor connector. Remove remaining oil pan bolts, oil pan and gasket.

Installation

Install Front/Rear Cover Alignment Tool (J 41480) to check for proper alignment of front and rear covers. If it is necessary to realign covers, see **FRONT COVER** and **REAR COVER** for alignment procedures. Apply a 1/4 inch bead of Sealant (12378190) at the point where front and rear covers meet block. Install oil pan with NEW oil pan gasket. Tighten oil pan-to-front cover and oil pan-to-block bolts to 18 ft. lbs. (25 N.m). Tighten oil pan-to-rear cover bolts to 106 INCH lbs. To complete installation, reverse removal procedure. Fill crankcase. Align front suspension as necessary. See appropriate SPECIFICATIONS & PROCEDURES article in WHEEL ALIGNMENT. Tighten bolts and nuts to specification. See **TORQUE SPECIFICATIONS** table.

OVERHAUL

CYLINDER HEAD

Valve Guides

Check and service guides before servicing valve and seat. Guide replacement information not available at time of publication. If valve stem clearance is .0037" (.093 mm) or more, valve and/or guide must be repaired or replaced.

Valve Seat

Valve seat replacement information not available at time of publication. Valve seat runout should not exceed .0021" (.05mm). Follow instructions of tool manufacturer for servicing valve seats. If seats are serviced, service or replace valves.

Valves

Check valves before servicing. Replace valves as necessary. DO NOT reface intake valves. See **VALVES & VALVE SPRINGS SPECIFICATIONS** table under ENGINE SPECIFICATIONS. Exhaust valve face may be machined if margin is .050" (1.25 mm) or more prior to grinding.

CYLINDER BLOCK ASSEMBLY

Piston & Rod Assembly

1. Before disassembling, mark rod and rod cap with matching cylinder number. Mark piston-to-rod relationship for reassembly reference. Notch or dot on piston top should

face front of engine. Piston pin is a press fit.

2. When measuring, ensure pin bore and piston pin are free of varnish and scuffing. If clearance between piston and pin exceeds specification, replace piston and pin as an assembly. See **PISTONS, PINS & RINGS SPECIFICATIONS** table under ENGINE SPECIFICATIONS.
3. The powdered metal rod is not repairable. Inspect rod bolt hole threads and mating surfaces, and rod bore for out-of-round condition. Check for rod twist, nicks, gouging and any other damage. If any damage exists, replace rod.

Fitting Pistons

Ensure notch or dot on piston top faces front of engine. Check pistons for wear and damage. Replace pistons as necessary. Check piston-to-cylinder bore clearance. A .010 oversize piston is available.

Piston Rings

Install marked side of ring toward top of piston. Ensure end gaps are evenly spaced on piston. See **Fig. 11**.

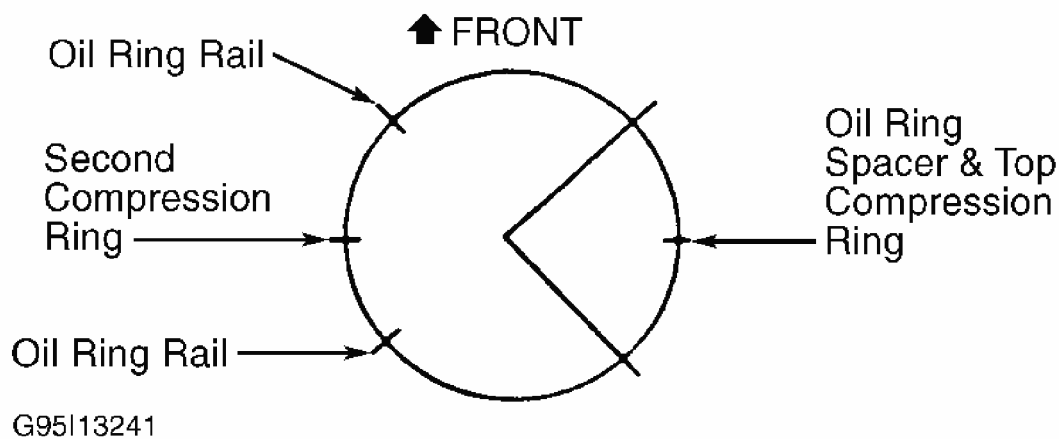

Fig. 11: Positioning Piston Ring End Gaps
Courtesy of GENERAL MOTORS CORP.

Rod Bearings

Ensure bearing cap bolt holes and mating surfaces are clean and dry. Use connecting rod stud protectors on rod cap bolts. Install inserts in connecting rod and cap. Lubricate bearings and crank pin. Install bearing cap. Tighten rod bearing cap bolts to specification. See **TORQUE SPECIFICATIONS** table.

Crankshaft & Main Bearings

1. Remove bearing cap M8 side bolts prior to cap removal. Remove bearing cap M10 bolts and studs. Install Crankshaft Bearing Cap Remover (J 41818) to the bearing cap. Tighten bearing cap remover bolts to 100 INCH lbs. (11 N.m). Install Slide Hammer (J 6125-1B) to bearing cap remover to remove cap. If bearing clearance is greater than specification, replace with undersize bearings. Recheck bearing clearance using Plastigage. Install NEW M8 main cap side bolts. Tighten main bearing cap bolts to initial torque in sequence. See **Fig. 12** . See **TORQUE SPECIFICATIONS** table.

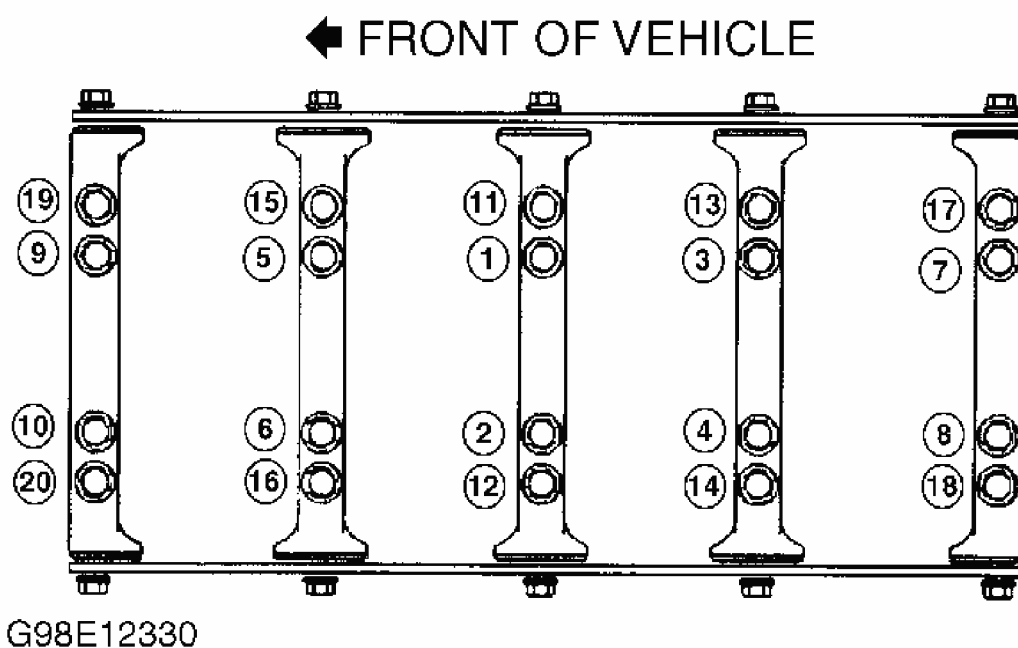

Fig. 12: Main Cap Bolt Tightening Sequence
 Courtesy of GENERAL MOTORS CORP.

2. Tighten main bearing cap bolts finger tight. Pry crankshaft rearward and then forward to align rear main bearing thrust surfaces. Retighten main bearing caps to specification. See **TORQUE SPECIFICATIONS** table.

Thrust Bearing

Check crankshaft end play by forcing crankshaft to extreme forward position. Measure end play at front of rear main bearing using a feeler gauge. If end play is not within specification, replace thrust bearing and/or crankshaft. See **CRANKSHAFT, MAIN & CONNECTING ROD BEARINGS SPECIFICATIONS** table under ENGINE SPECIFICATIONS.

Cylinder Block

Check cylinder bore for wear, taper, out-of-round and piston fit. See **CYLINDER BLOCK SPECIFICATIONS** table under ENGINE SPECIFICATIONS. Cylinders with less than .010" (.25mm) wear or taper can be honed. A .010" oversize piston and ring set is available for service. Cylinders with more than .010" (.25mm) wear or taper are not serviceable. DO NOT bore engine.

ENGINE OILING

ENGINE LUBRICATION SYSTEM

A gerotor-type oil pump provides pressurized lubrication through full-flow oil filter. Oil pump is bolted to front of cylinder block, behind front cover, and is driven directly by crankshaft. See **Fig. 13** .

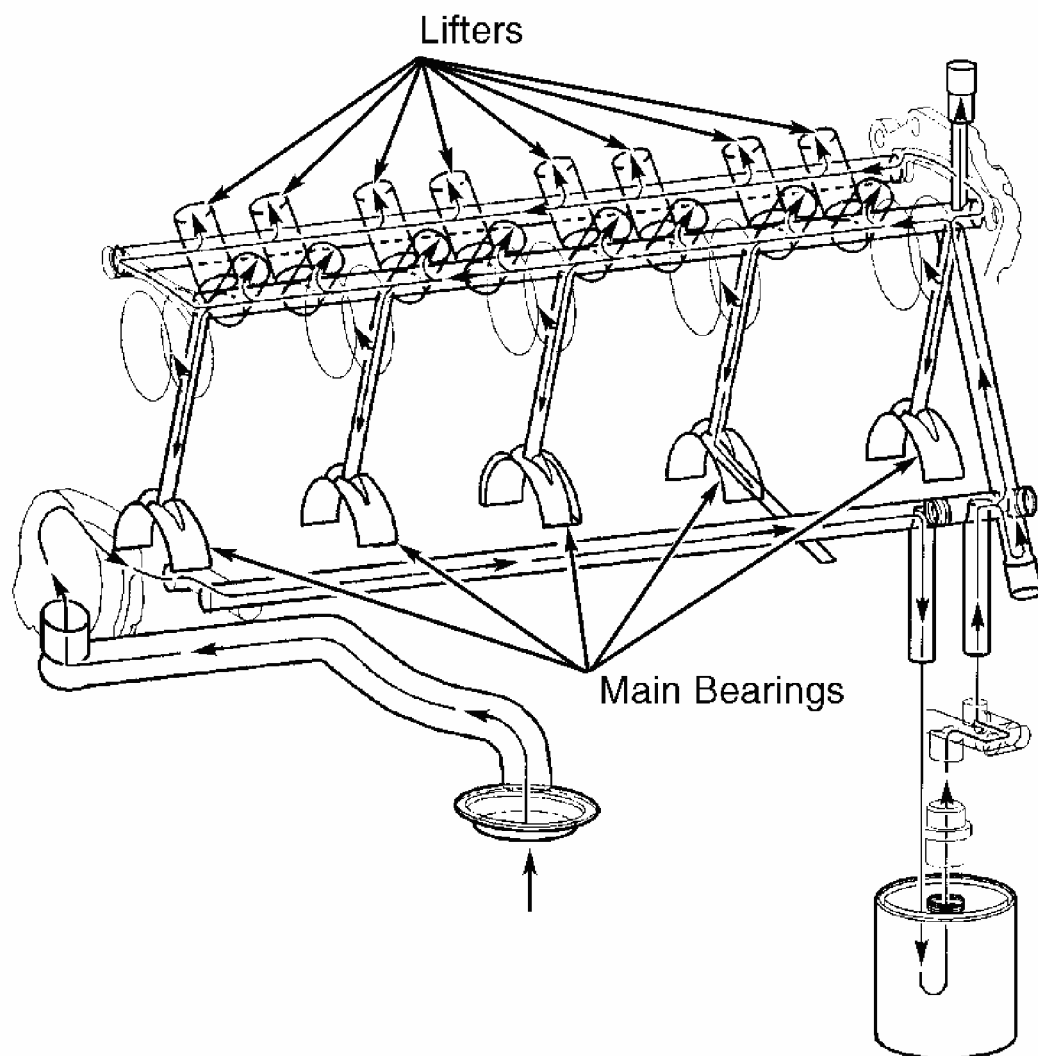

1999 Chevrolet Corvette

1998-99 ENGINES 5.7L V8 - Corvette

Fig. 13: Identifying Lubrication System Courtesy of GENERAL MOTORS CORP.

Oil Capacity

Crankcase capacity is 6.0 qts. (5.7L) without oil filter change, or 6.5 qts. (6.2L) with oil filter change.

Oil Pressure

With engine at normal operating temperature, oil pressure should be at least 6 psi (0.4 kg/cm²) at 1000 RPM, 18 psi (1.3 kg/cm²) at 2000 RPM and 24 psi (1.7 kg/cm²) at 4000 RPM.

OIL PUMP

Removal & Disassembly

Remove front cover. See **FRONT COVER** under REMOVAL & INSTALLATION. Remove oil pan. See **OIL PAN** under REMOVAL & INSTALLATION. Remove oil pump, pump pick-up screen and deflector. Remove oil pump cover bolts and cover. Mark gear teeth for reassembly reference. Remove gears. Remove pressure regulator plug, spring and valve from cover. Remove pick-up screen and pipe.

Inspection

Check oil pump housing and cover for cracks, wear, scoring and casting imperfections. Check oil pump housing-to-engine block oil gallery surface for scratches or gouging. If excess wear or damage is found, replace oil pump as an assembly. Oil pump clearance specifications not available at time of publication. Inspect pump screen for debris or restrictions. Inspect pump screen for broken or loose wire mesh. Oil pump pipe and pick-up screen are to be serviced as an assembly. DO NOT attempt to repair pipe and pick-up screen assembly.

Reassembly & Installation

Clean parts in solvent. Dry parts using compressed air. To assemble, reverse disassembly procedure. To install, reverse removal procedure. Tighten oil pump cover bolts to 106 INCH lbs. (12 N.m).

TORQUE SPECIFICATIONS

TORQUE SPECIFICATIONS

Application	Ft. Lbs. (N.m)
Air Injection Pipe-To-Exhaust Manifold Bolts	15 (20)
Camshaft Retainer Bolt	18 (25)

1999 Chevrolet Corvette

1998-99 ENGINES 5.7L V8 - Corvette

Camshaft Sensor Bolt	18 (25)
Camshaft Sprocket Bolt	18 (25)
Connecting Rod Cap Bolts	
Step 1	15 (20)
Step 2	Additional 60 Degrees
Crankshaft Balancer Bolt	
With Original Bolt To Seat Balancer	240 (330)
Step 1 With New Bolt	37 (50)
Step 2 With New Bolt	Additional 120 Degrees
Crankshaft Oil Deflector Nuts	18 (25)
Crankshaft Oil Seal Cover To Block Bolt (Front & Rear)	11 (15)
Crankshaft Position Sensor Bolts	18 (25)
Cylinder Head Bolts	(1)
Drive Belt Idler Pulley Bolt	37 (50)
Drive Belt Tensioner Bolt	37 (50)
Engine Mount Through-Bolts	70 (95)
Exhaust Manifold Bolts	
Step 1	11 (15)
Step 2	18 (25)
Flexplate/Flywheel-To-Crankshaft Bolts ⁽²⁾	
Step 1	15 (20)
Step 2	37 (50)
Step 3	74 (100)
Flywheel Hub Collar Bolt (A/T)	96 (130)
Knock Sensors	15 (20)
Main Bearing Cap ⁽³⁾	
Inner Bolts	
Step 1	15 (20)
Step 2	Additional 80 Degrees
Outer Studs	
Step 1	15 (20)
Step 2	Additional 53 Degrees
Side Bolts	18 (25)
Oil Level Sensor	26 (35)

1999 Chevrolet Corvette

1998-99 ENGINES 5.7L V8 - Corvette

Oil Pan	
M6 Bolts	(4)
M8 Bolts	18 (25)
Oil Pump Screen Nuts	18 (25)
Oil Pump Screen-To-Oil Pump Bolt	(4)
Oil Pump-To-Block Bolt	18 (25)
Oxygen Sensor	31 (42)
Rocker Arm Bolts	22 (30)
Spark Plugs	12 (15)
Starter Bolts	37 (50)
Transmission-To-Driveline Support Assembly Bolts	37 (50)
Valley Cover Bolts	18 (25)
Valve Lifter Guide Bolts	18 (25)
Water Pump Bolts	18 (25)
Water Pump Cover Bolts	11 (15)
Water Pump Pulley Bolts	18 (25)
INCH Lbs. (N.m)	
Flywheel Cover Bolts	106 (12)
Fuel Rail Bolts	89 (10)
Ignition Coil Bolts	106 (12)
Intake Manifold Bolts ⁽⁵⁾	
Step 1	44 (5)
Step 2	74 (8)
Oil Pump Cover Bolts	106 (12)
Throttle Body Bolts	106 (12)
Valve Cover Bolts	106 (12)
Vapor Vent Pipe Bolts	106 (12)

(1) See INSTALLATION under **CYLINDER HEADS** for procedure and specifications. See **Fig. 5** .

(2) Tighten bolts evenly using a crisscross sequence.

(3) Tighten bolts in sequence. See **Fig. 12** .

(4) Tighten to 106 INCH lbs. (12 N.m)

(5) Tighten bolts in sequence. See **Fig. 4** .

ENGINE SPECIFICATIONS

1999 Chevrolet Corvette

1998-99 ENGINES 5.7L V8 - Corvette

GENERAL SPECIFICATIONS

Application	Specification
Displacement	350 Cu. In. (5.7L)
Bore	3.898" (99.00 mm)
Stroke	3.622" (92.00 mm)
Compression Ratio	10.1:1

CRANKSHAFT, MAIN & CONNECTING ROD BEARINGS SPECIFICATIONS

Application	In. (mm)
Crankshaft	
End Play	.0015-.0078 (.04-.22)
Runout At Rear Flange (Maximum)	.0020 (.050)
Main Bearings	
Journal Diameter	2.558-(64.980)
Journal Out-Of-Round	
Standard	.0001 (.003)
Wear Limit	.0003 (.008)
Journal Taper	
Standard	.0004 (.010)
Wear Limit	.0008 (.020)
Reluctor Ring	
Runout ⁽¹⁾	.010 (.25)
Oil Clearance	.0007-.0021 (.018-.054)
Connecting Rod Bearings	
Journal Diameter	2.099 (53.31)
Journal Out-Of-Round	
Standard	.0002 (.005)
Wear Limit	.0004 (.010)
Journal Taper ⁽²⁾	
Standard	.0002 (.005)
Wear Limit	.0004 (.010)
Oil Clearance	.0006-.0003 (.015-.063)

(1) Measured .40" (1 mm) below tooth diameter

(2) Maximum for half of journal length.

1999 Chevrolet Corvette

1998-99 ENGINES 5.7L V8 - Corvette

CONNECTING RODS SPECIFICATIONS

Application	In. (mm)
Bearing Bore Diameter	2.224-2.225 (56.50-56.52)
Maximum Bend	(1)
Maximum Twist	(1)
Side Play	.004-.020 (.11-.51)
(1) Replace rod if any bend or twist exists.	

PISTONS, PINS & RINGS SPECIFICATIONS

Application	In. (mm)
Piston Clearance	
Standard	.0007-.0021 (.018-.054)
Wear Limit	.0007-.0021 (.018-.054)
Pins	
Diameter	.9447-.9448 (23.997-24.000)
Rod Fit (Interference)	.0008-.0017 (.020-.043)
Rings	
No. 1	
End Gap	.009-.015 (.23-.38)
Side Clearance	.00157-.00335 (.040-.085)
No. 2	
End Gap	.0017-.0025 (.044-.064)
Side Clearance	.00157-.00315 (.040-.080)
No. 3 (Oil)	
End Gap	.0070-.0271 (.178-.688)
Side Clearance	.0004-.0087 (.010-.220)

CYLINDER BLOCK SPECIFICATIONS

Application	In. (mm)
Cylinder Bore	
Diameter	3.897-3.898 (99.000-99.018)
Taper (Thrust Side)	.0004 (.010)

VALVES & VALVE SPRINGS SPECIFICATIONS

Application	In. (mm)

1999 Chevrolet Corvette

1998-99 ENGINES 5.7L V8 - Corvette

Application	Specification
Valves	
Face Angle	45°
Margin (Minimum)	.050" (1.25 mm)
Stem Diameter	.313-.314" (7.955-7.976 mm)
Valve Springs	
Free Length	2.08" (52.90 mm)
Installed Height	1.80" (45.75 mm)
Lbs. @ In. (N @ mm)	
Valve Spring Pressure	
Valve Closed	76 @ 1.80 (340 N @ 45.75)
Valve Open	220 @ 1.32 (980 N @ 33.55)

CYLINDER HEAD SPECIFICATIONS

Application	Specification
Valve Seats	
Intake Valve	
Seat Angle	46°
Seat Width	.040" (1.02 mm)
Exhaust Valve	
Seat Angle	46°
Seat Width	.070" (1.78 mm)
Valve Guides	
Stem-To-Guide Oil Clearance	
Standard	.0010-.0026" (.025-.066 mm)
Wear Limit	.0037" (.093 mm)

CAMSHAFT SPECIFICATIONS

Application	In. (mm)
End Play	.001-.012 (.025-.305)
Journal Diameter	2.164-2.166 (54.99-55.04)
Lobe Lift	
Intake	.277 (7.04)
Exhaust	.281 (7.13)