

**2001 Chevrolet Corvette**

2001 SYSTEM WIRING DIAGRAMS CHEVROLET Corvette

**2001 SYSTEM WIRING DIAGRAMS CHEVROLET**

**Corvette**

**AIR CONDITIONING**

# 2001 Chevrolet Corvette

## 2001 SYSTEM WIRING DIAGRAMS CHEVROLET Corvette

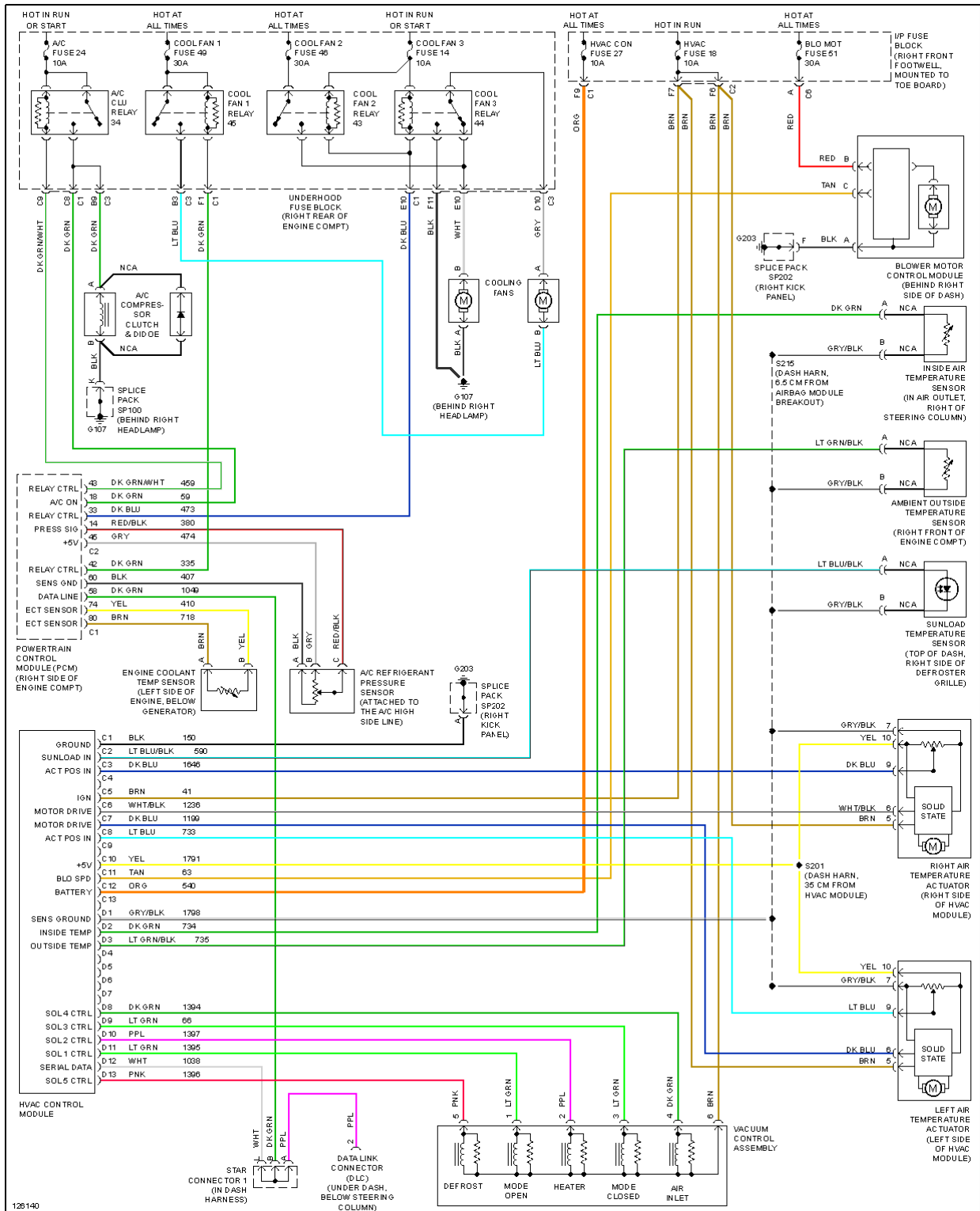

**Fig. 1: Automatic A/C Circuit**

# 2001 Chevrolet Corvette

## 2001 SYSTEM WIRING DIAGRAMS CHEVROLET Corvette

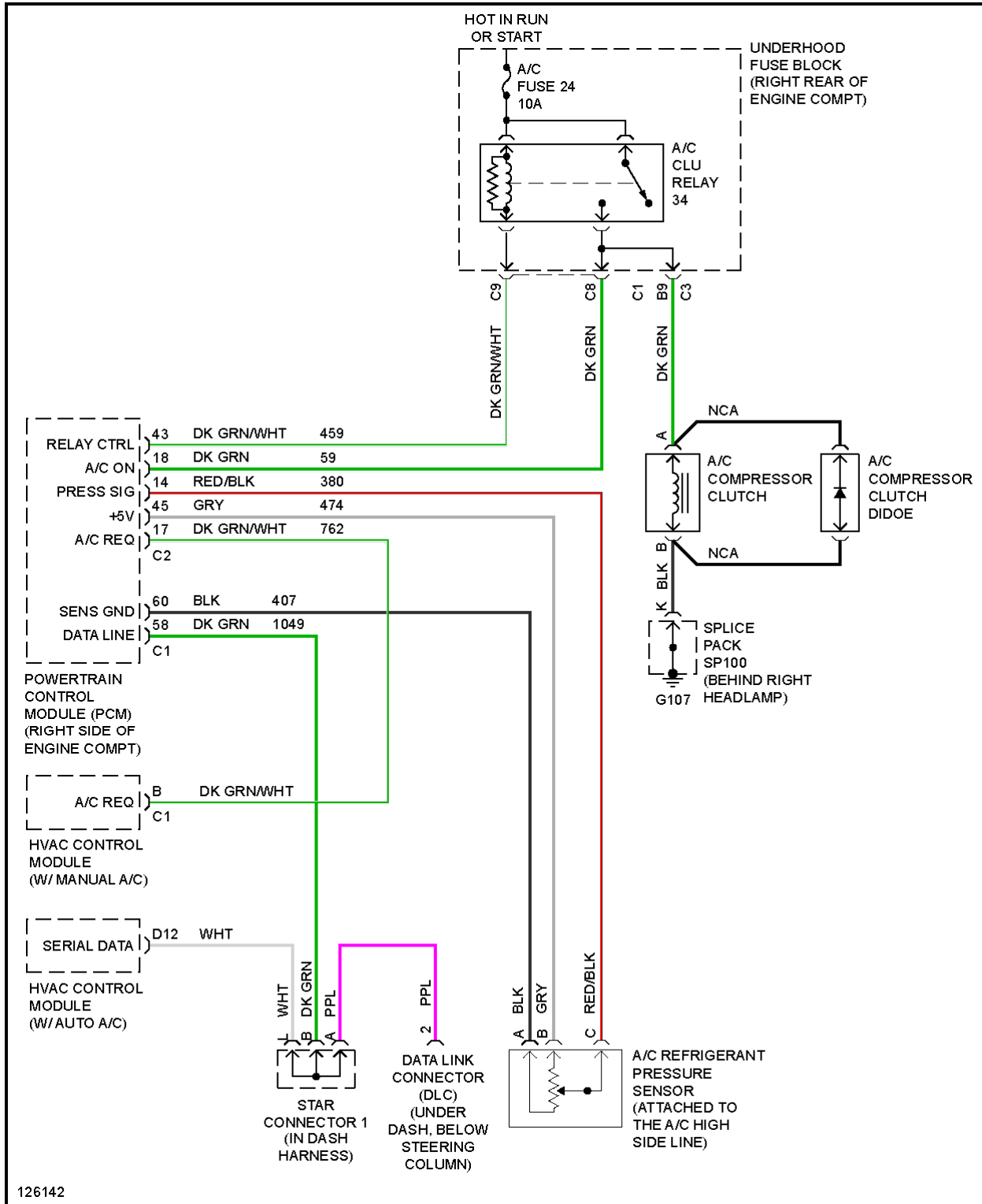

**Fig. 2: Compressor Circuit**

# 2001 Chevrolet Corvette

## 2001 SYSTEM WIRING DIAGRAMS CHEVROLET Corvette

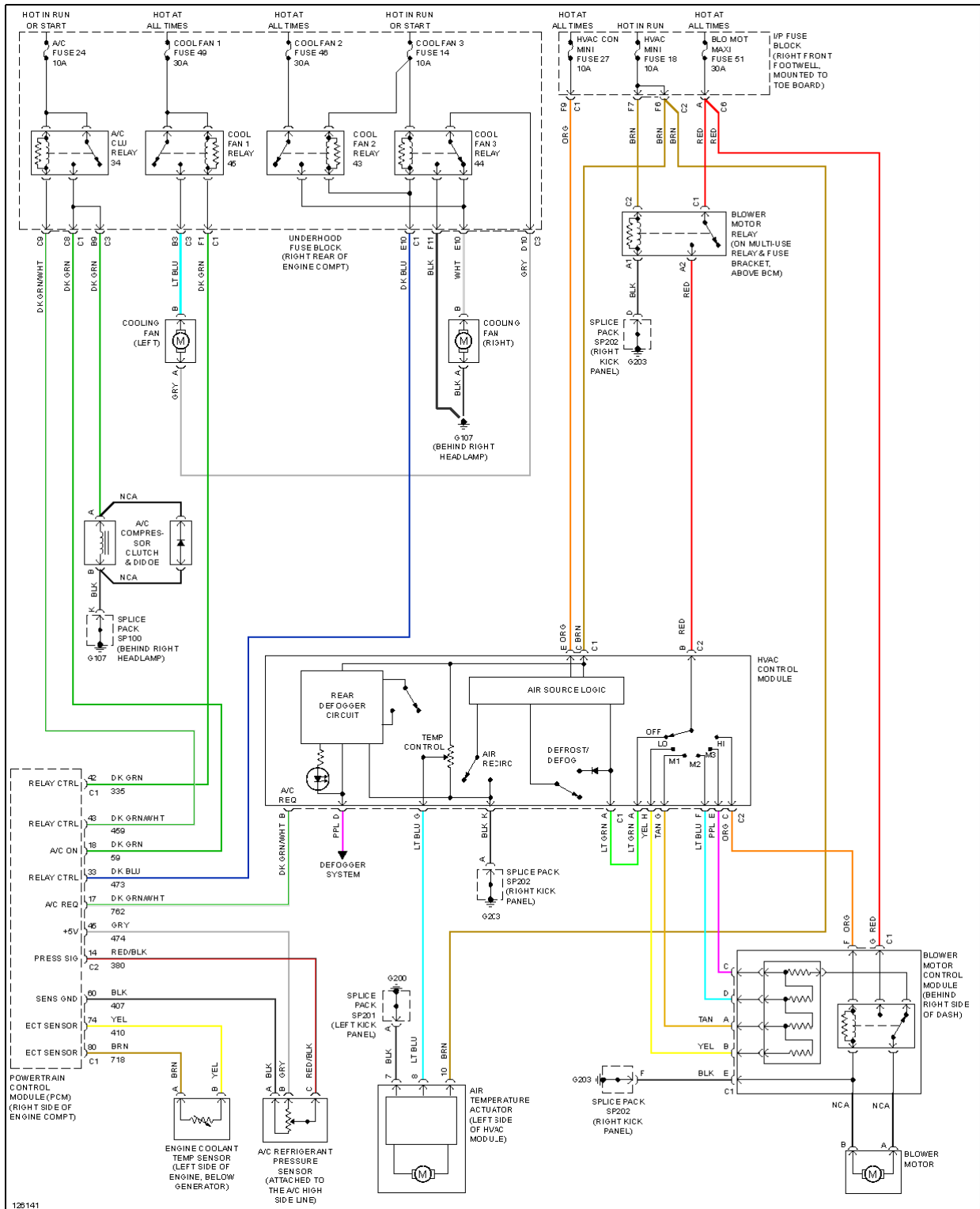
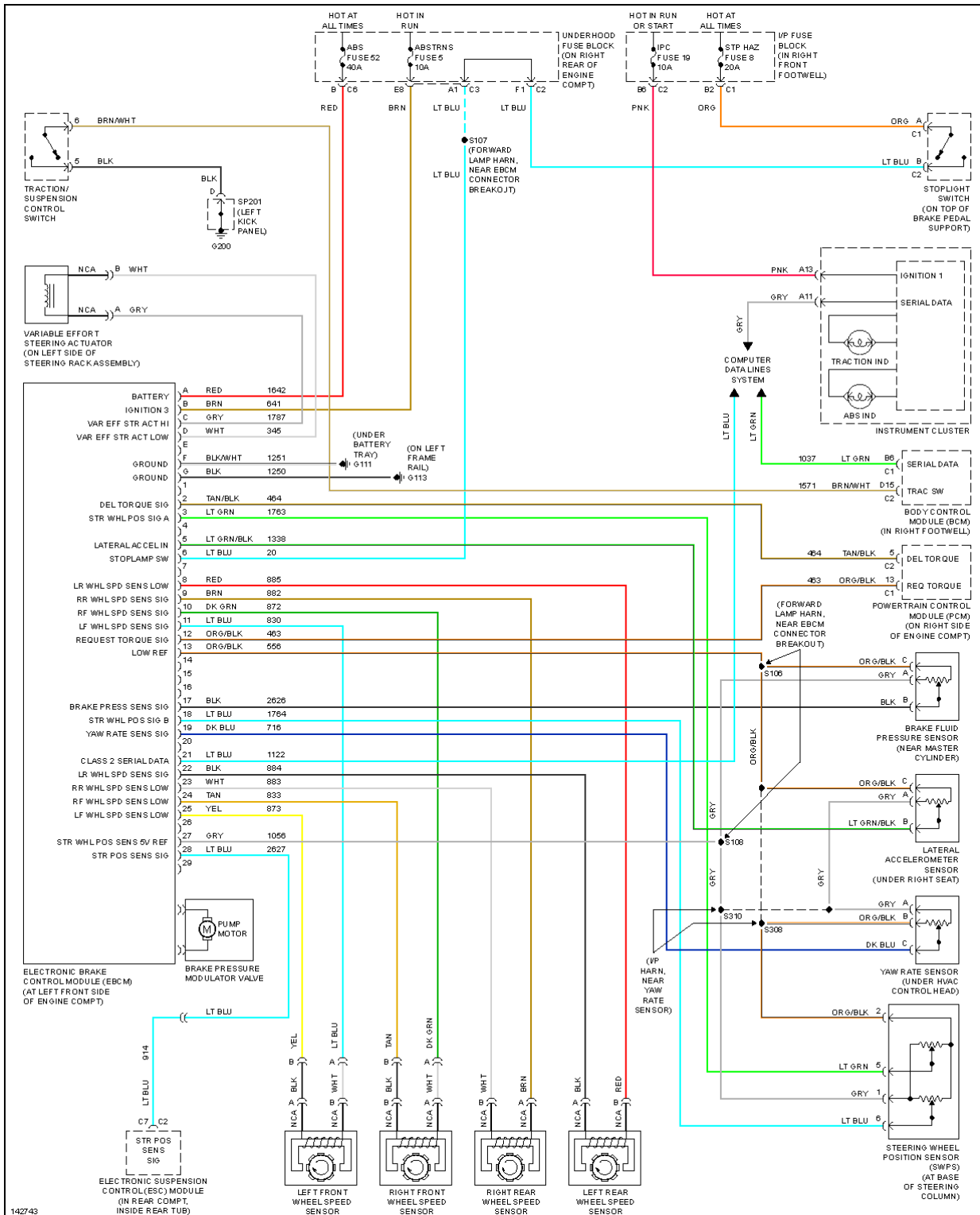

**Fig. 3: Manual A/C Circuit**

**ANTI-LOCK BRAKES**

# 2001 Chevrolet Corvette

## 2001 SYSTEM WIRING DIAGRAMS CHEVROLET Corvette



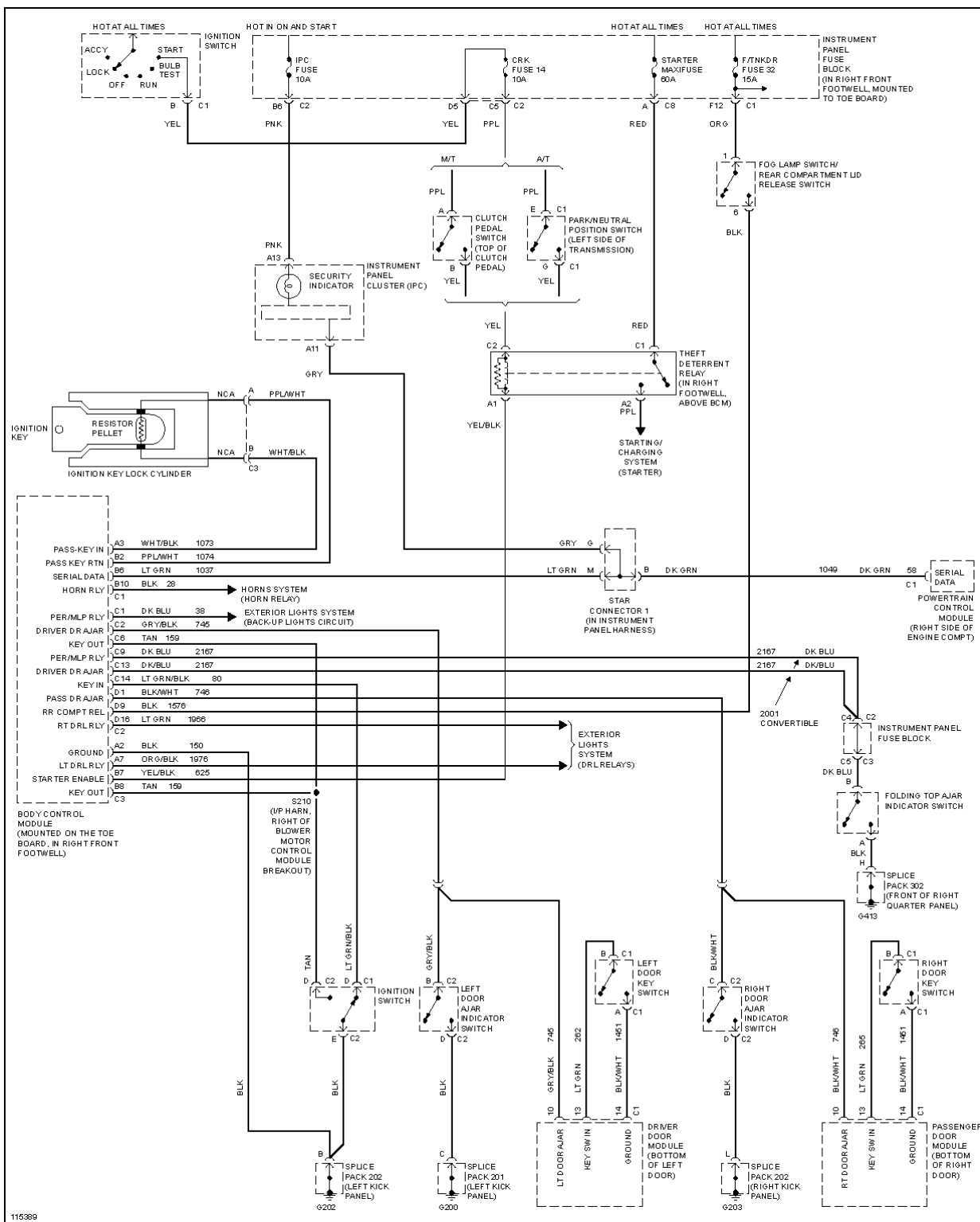

**Fig. 4: Anti-lock Brake Circuits**

**ANTI-THEFT**

# 2001 Chevrolet Corvette

## 2001 SYSTEM WIRING DIAGRAMS CHEVROLET Corvette

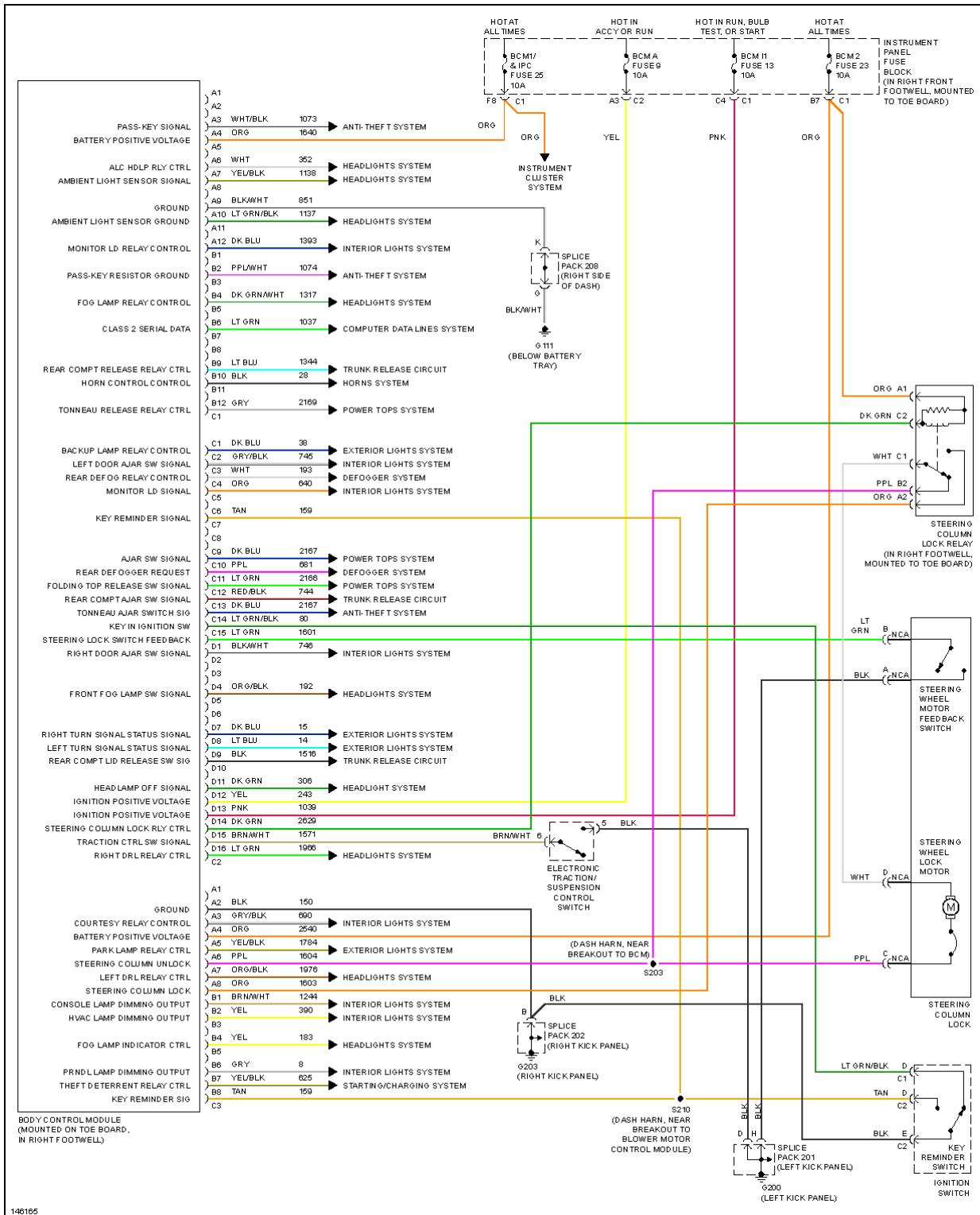

**Fig. 5: Anti-theft Circuit**

**BODY COMPUTER**

# 2001 Chevrolet Corvette

## 2001 SYSTEM WIRING DIAGRAMS CHEVROLET Corvette

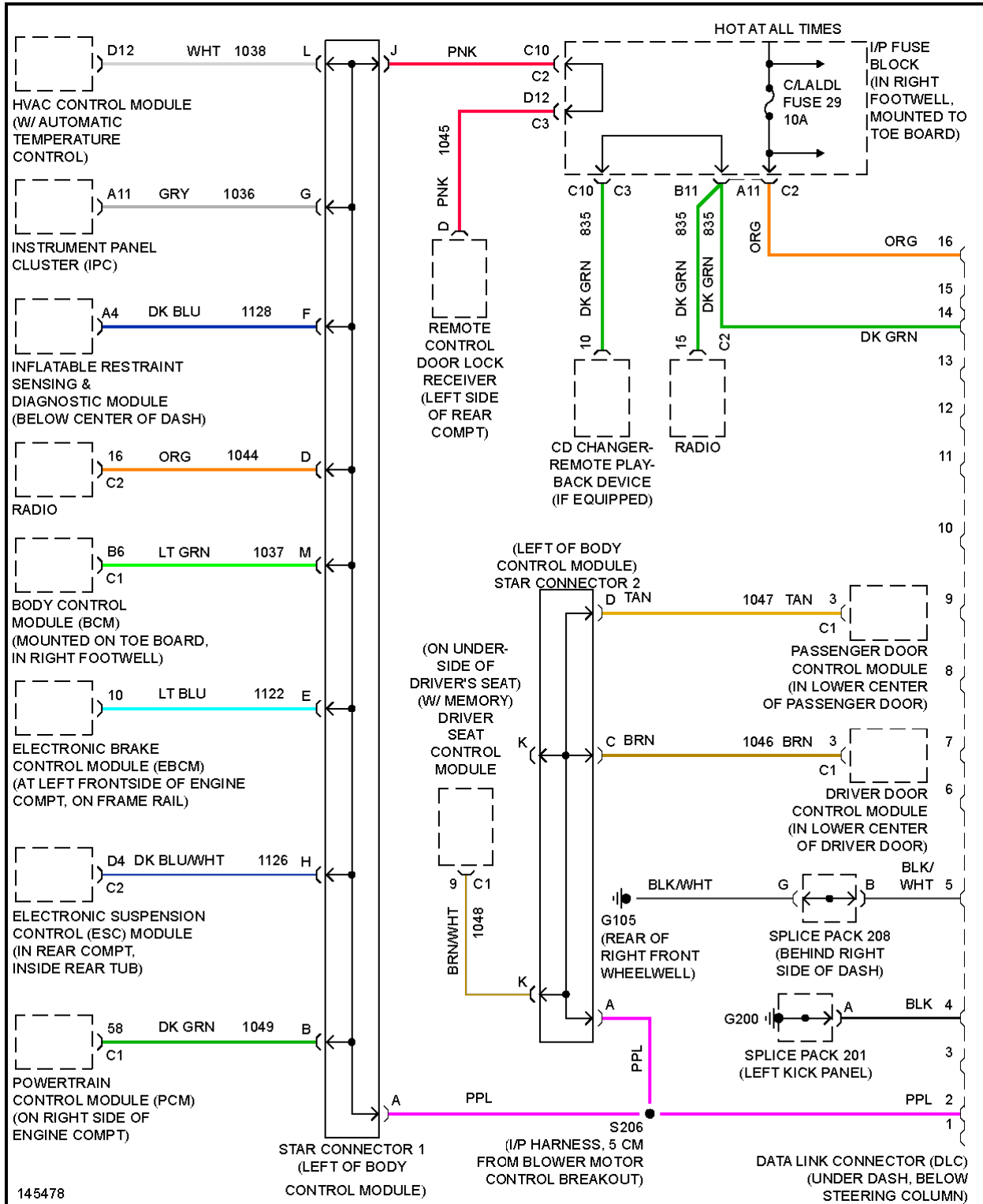

**Fig. 6: Body Computer Circuits**

**COMPUTER DATA LINES**

# 2001 Chevrolet Corvette

## 2001 SYSTEM WIRING DIAGRAMS CHEVROLET Corvette

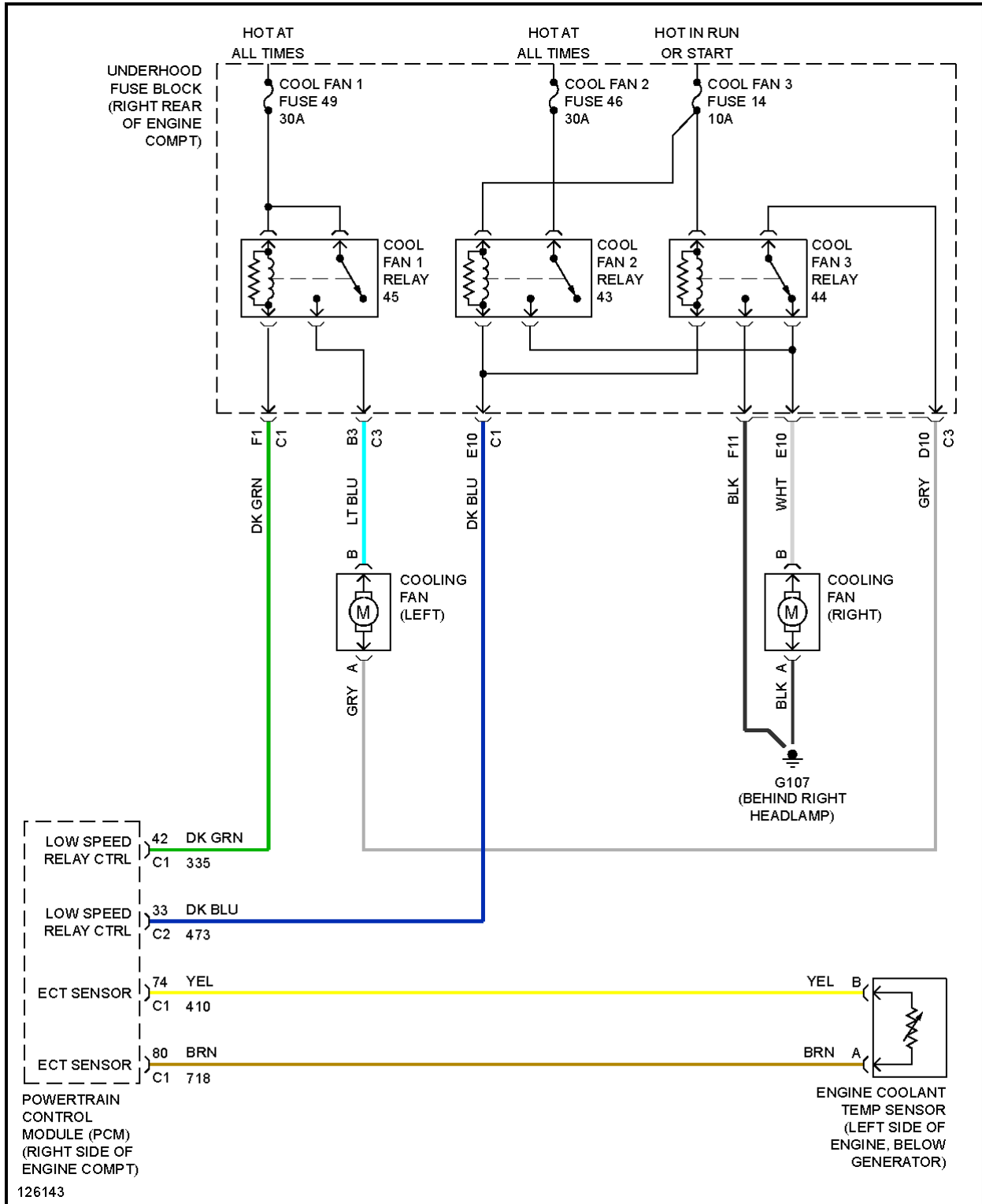

**Fig. 7: Computer Data Lines**

**COOLING FAN**

# 2001 Chevrolet Corvette

## 2001 SYSTEM WIRING DIAGRAMS CHEVROLET Corvette



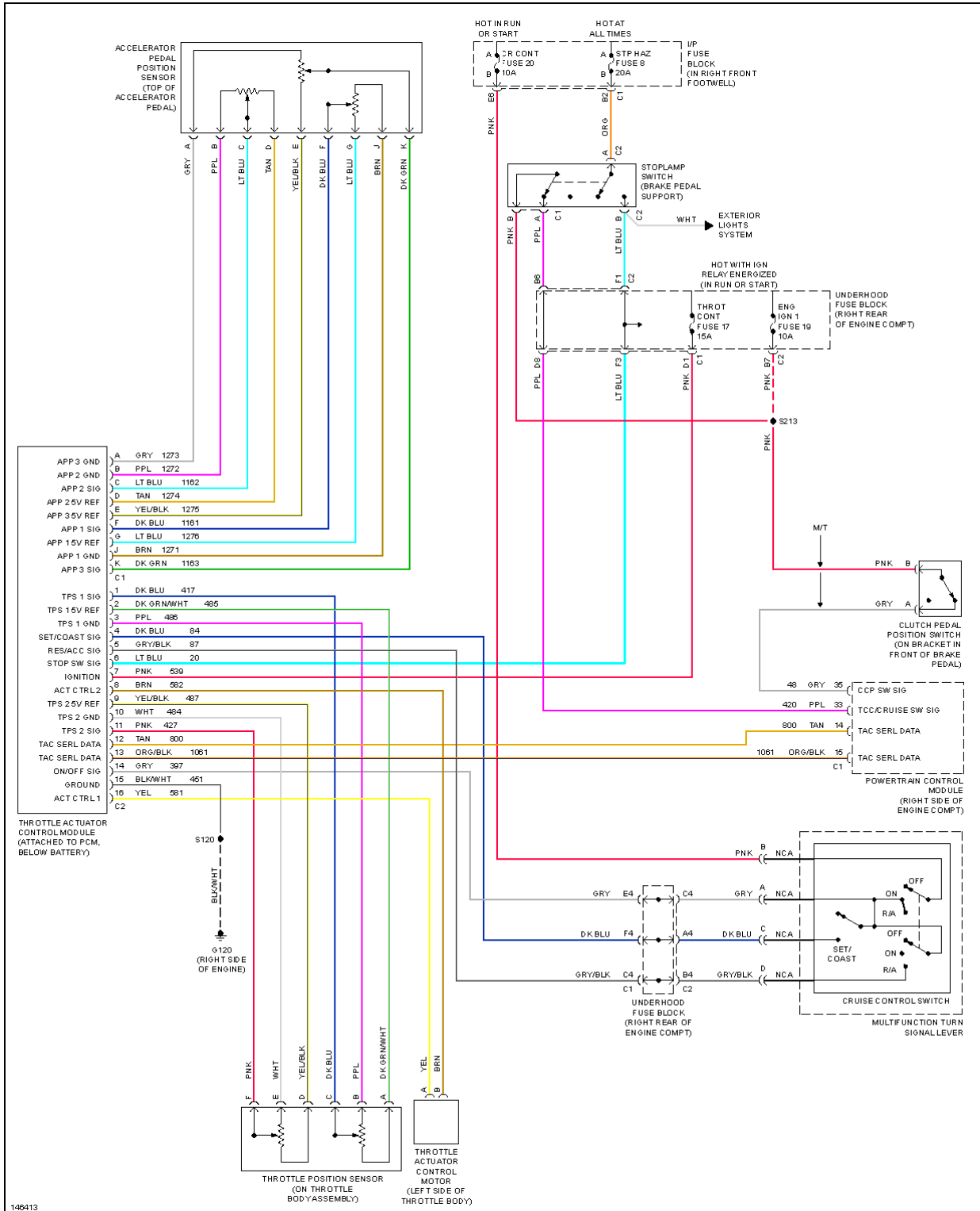

**Fig. 8: Cooling Fan Circuit**

**CRUISE CONTROL**

# 2001 Chevrolet Corvette

## 2001 SYSTEM WIRING DIAGRAMS CHEVROLET Corvette

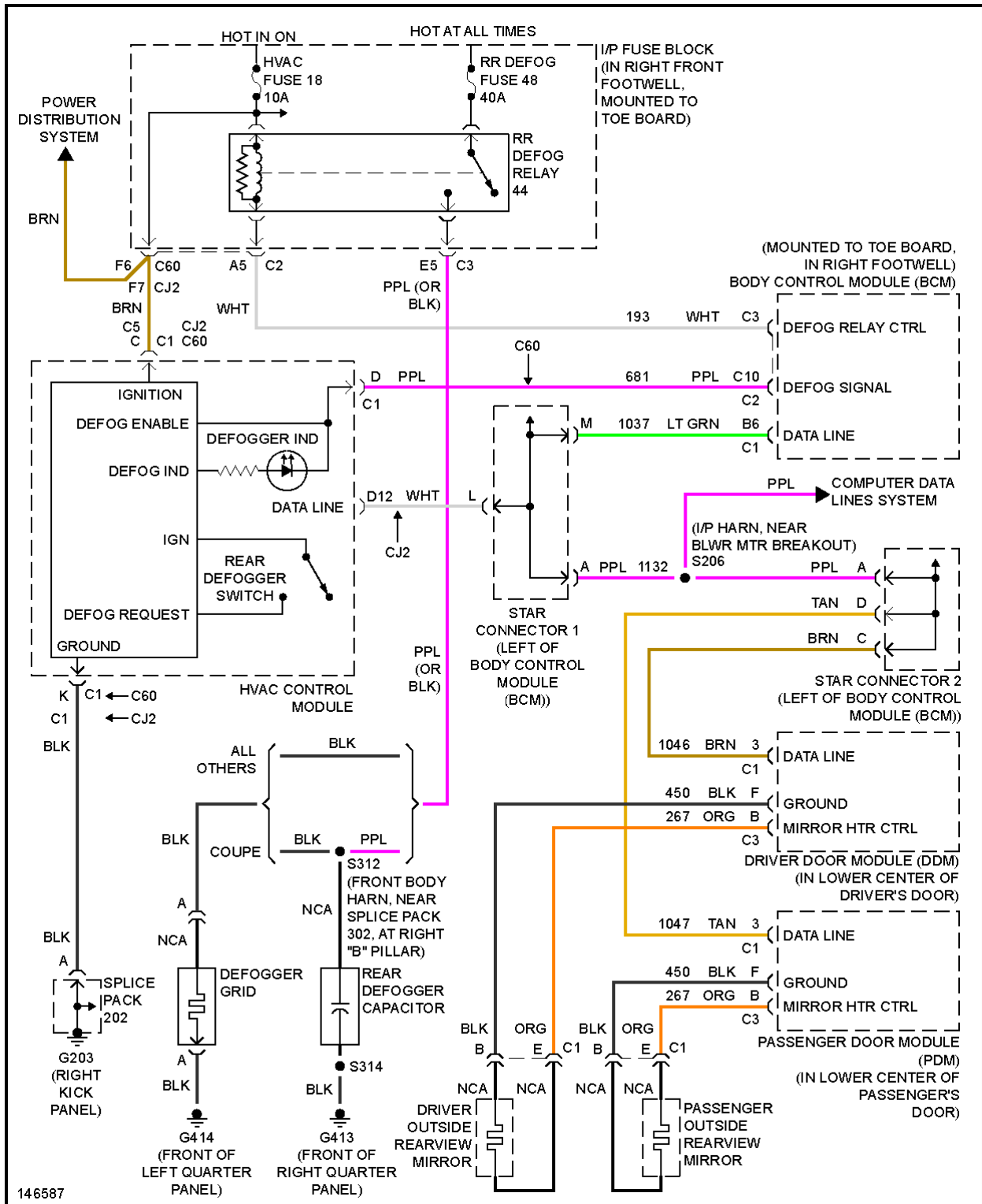

**Fig. 9: Cruise Control Circuit**

**DEFOGGERS**

# 2001 Chevrolet Corvette

## 2001 SYSTEM WIRING DIAGRAMS CHEVROLET Corvette

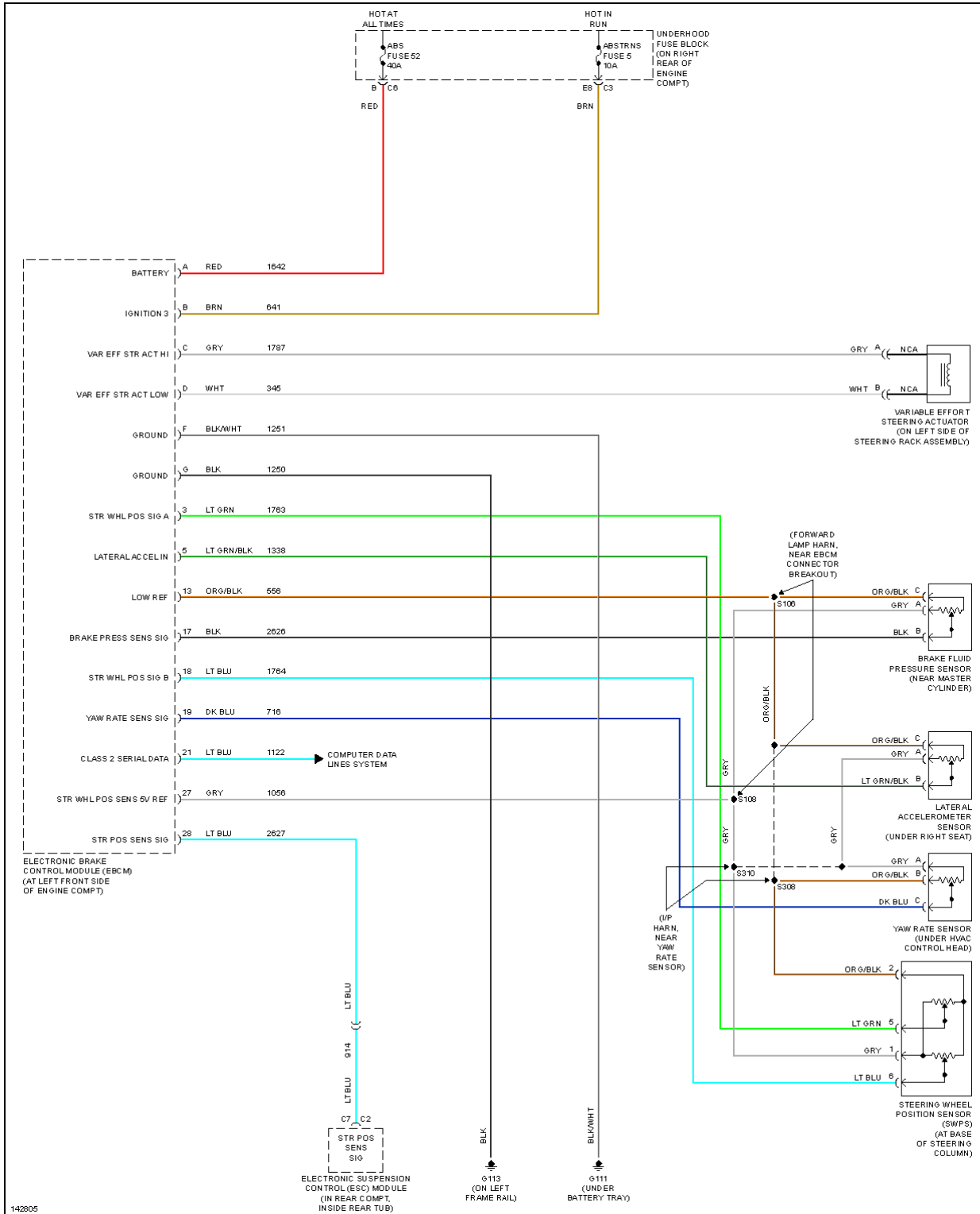

**Fig. 10: Defogger Circuit**

**ELECTRONIC POWER STEERING**

# 2001 Chevrolet Corvette

## 2001 SYSTEM WIRING DIAGRAMS CHEVROLET Corvette

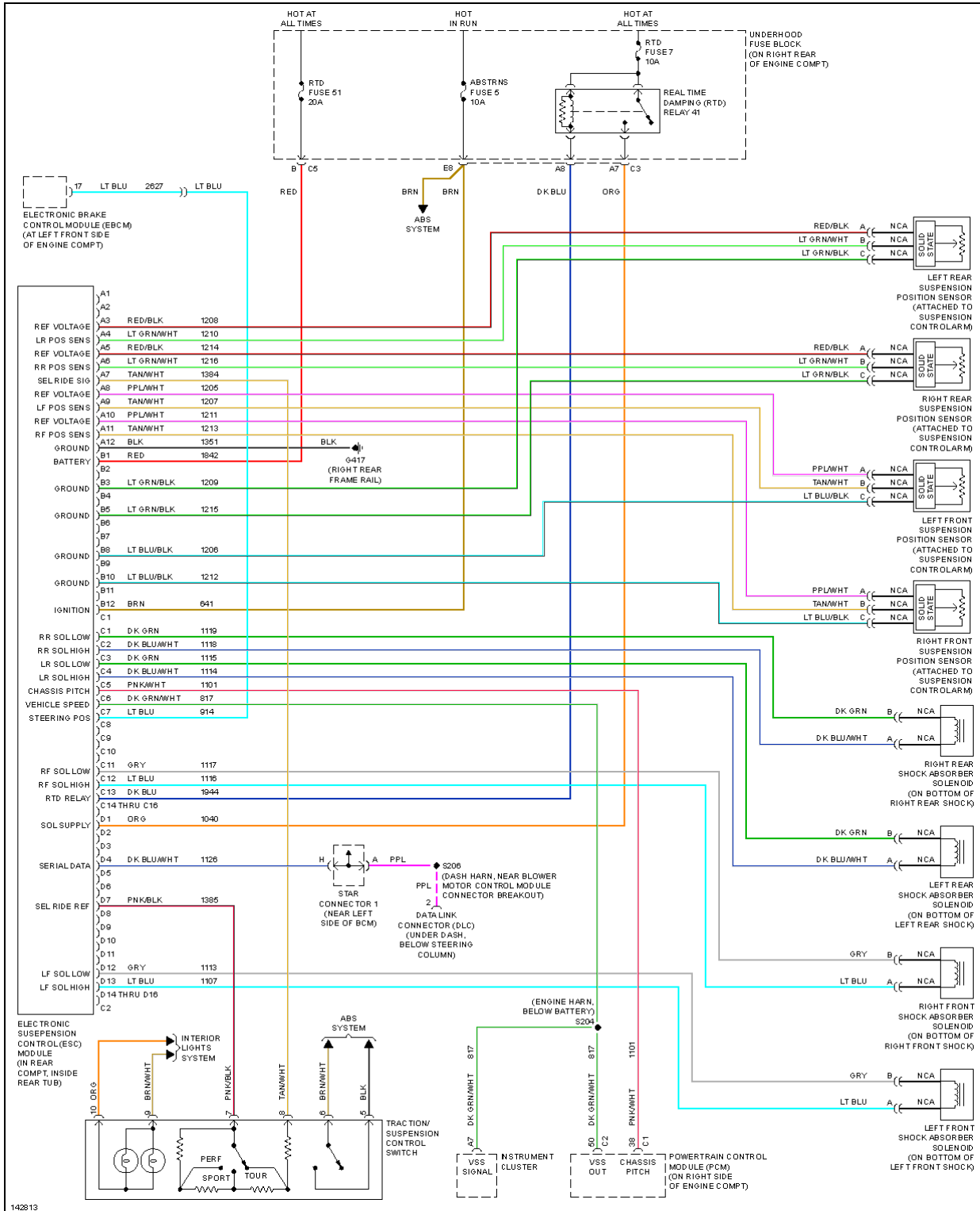

**Fig. 11: Electronic Power Steering Circuit**

**ELECTRONIC SUSPENSION**

# 2001 Chevrolet Corvette

## 2001 SYSTEM WIRING DIAGRAMS CHEVROLET Corvette





**Fig. 12: Electronic Suspension Circuit**

**ENGINE PERFORMANCE**

5.7L

# 2001 Chevrolet Corvette

## 2001 SYSTEM WIRING DIAGRAMS CHEVROLET Corvette

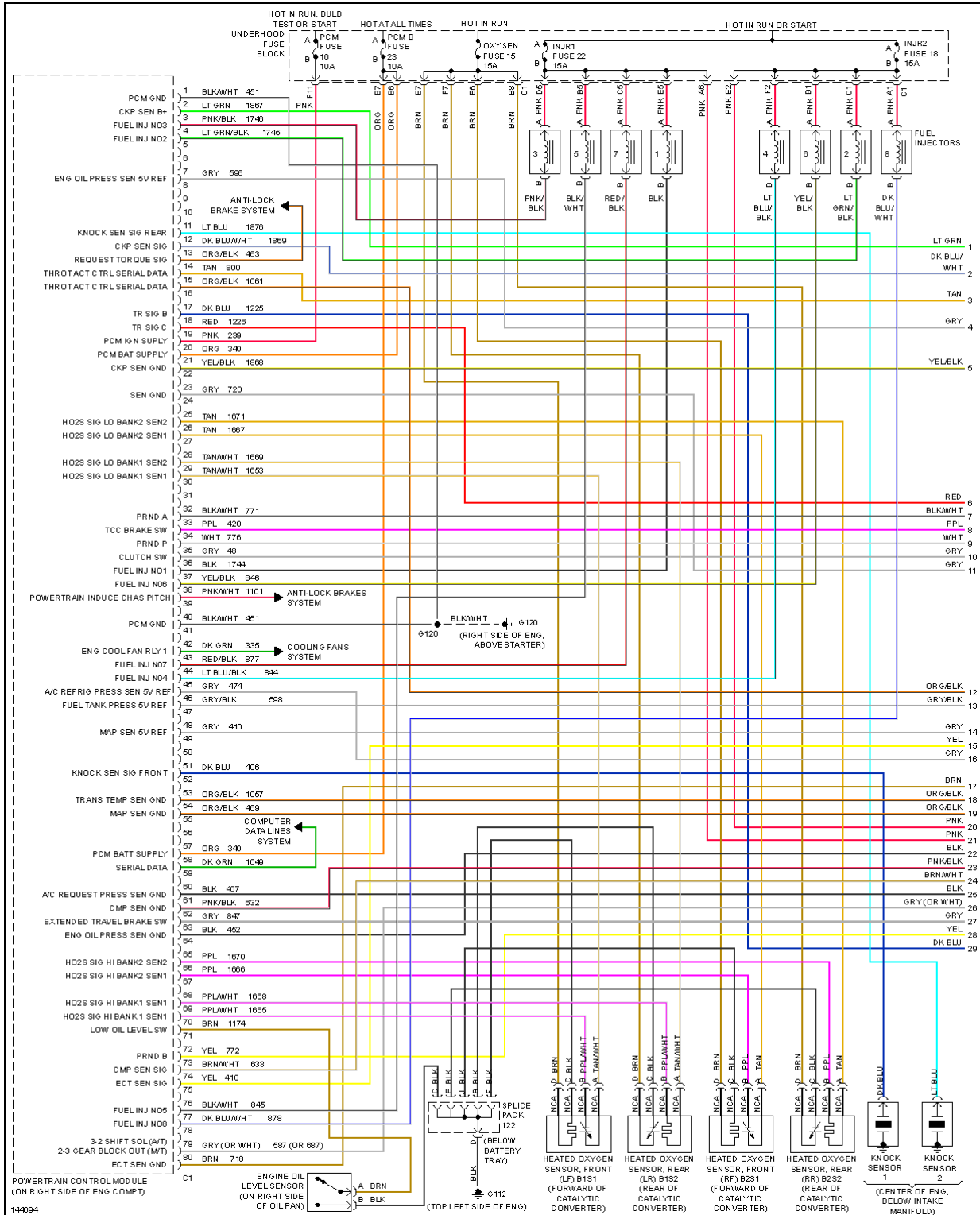

**Fig. 13: 5.7L VIN G, Engine Performance Circuits (1 of 4)**

# 2001 Chevrolet Corvette

## 2001 SYSTEM WIRING DIAGRAMS CHEVROLET Corvette

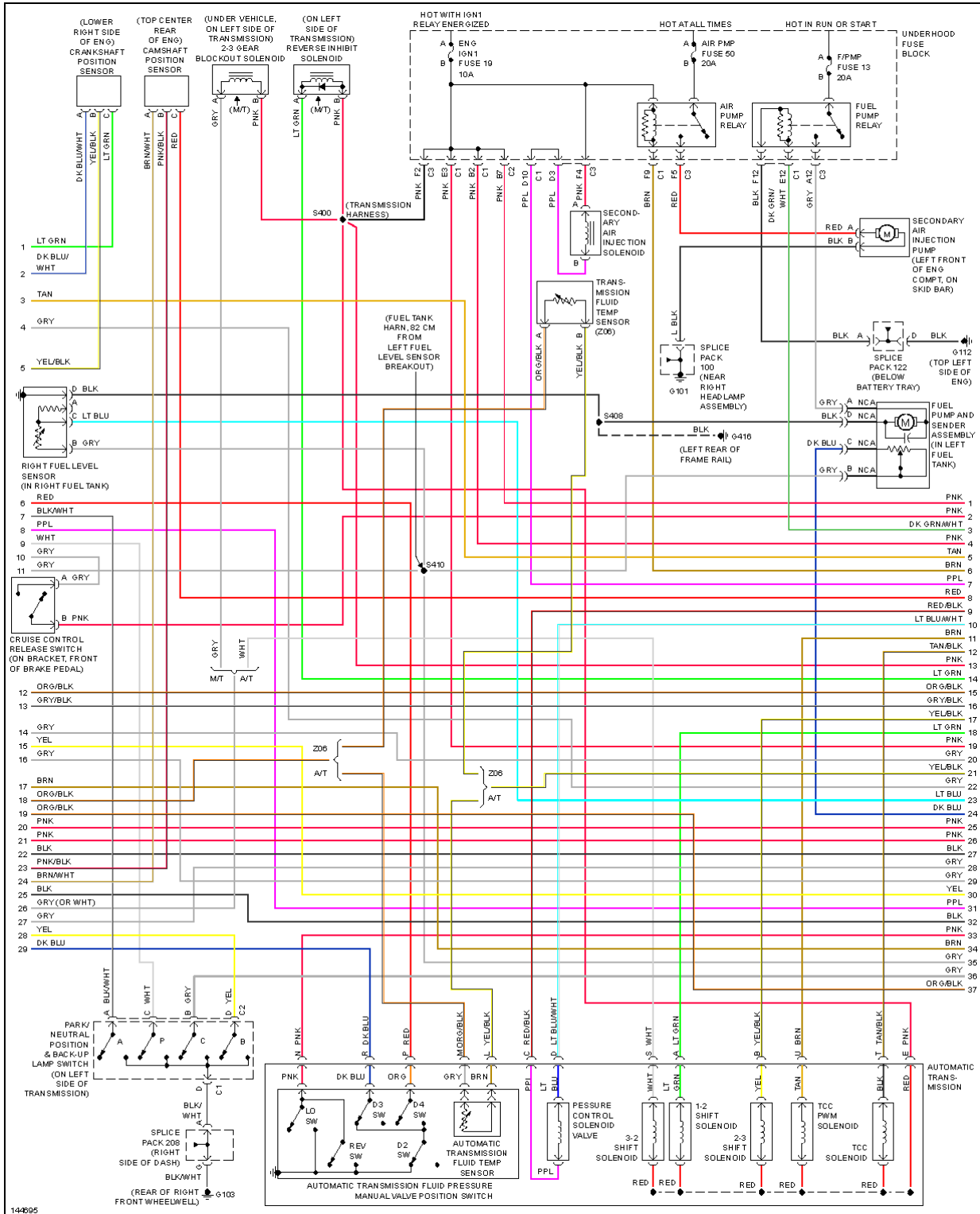

**Fig. 14: 5.7L VIN G, Engine Performance Circuits (2 of 4)**

# 2001 Chevrolet Corvette

## 2001 SYSTEM WIRING DIAGRAMS CHEVROLET Corvette

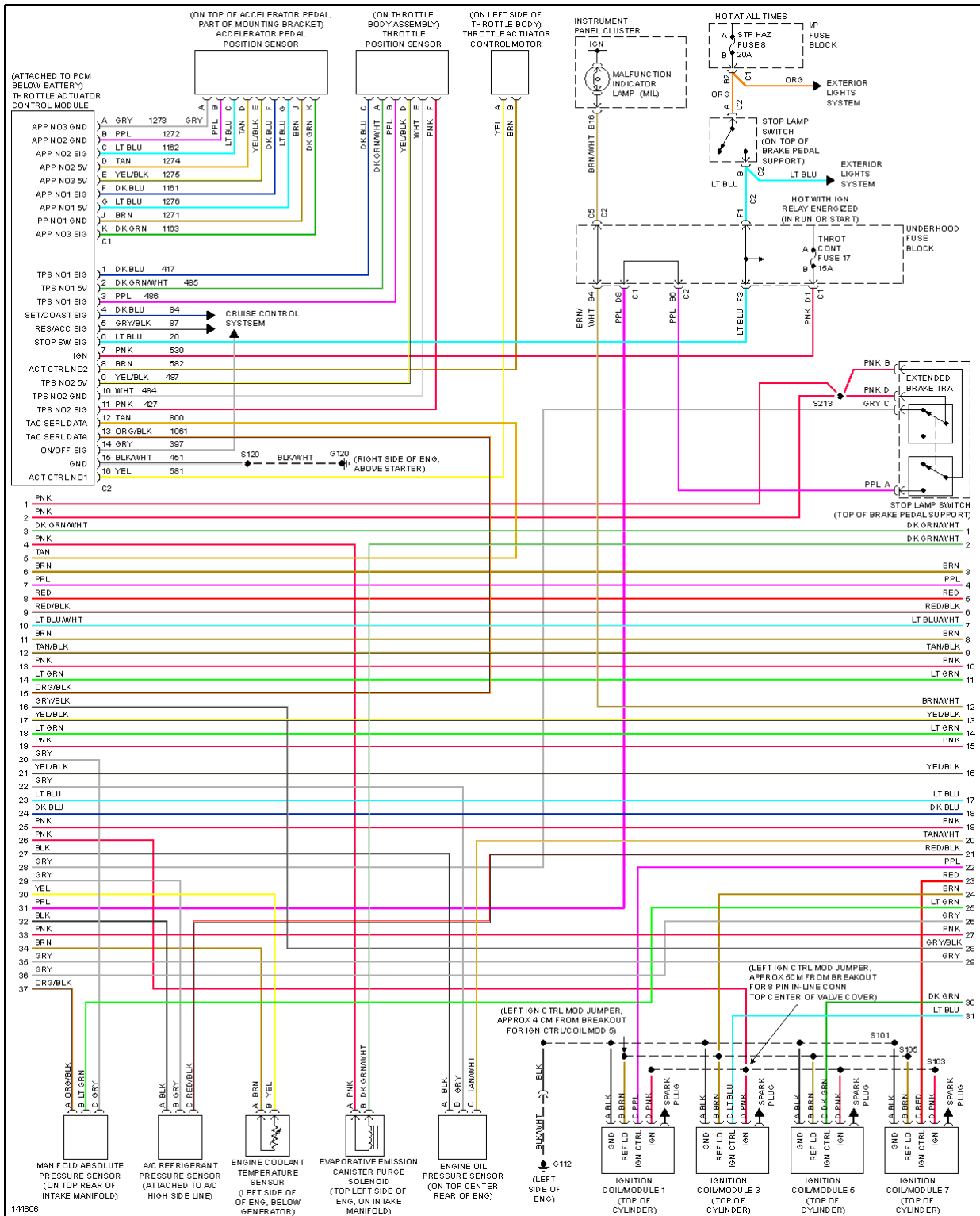

**Fig. 15: 5.7L VIN G, Engine Performance Circuits (3 of 4)**

# 2001 Chevrolet Corvette

## 2001 SYSTEM WIRING DIAGRAMS CHEVROLET Corvette

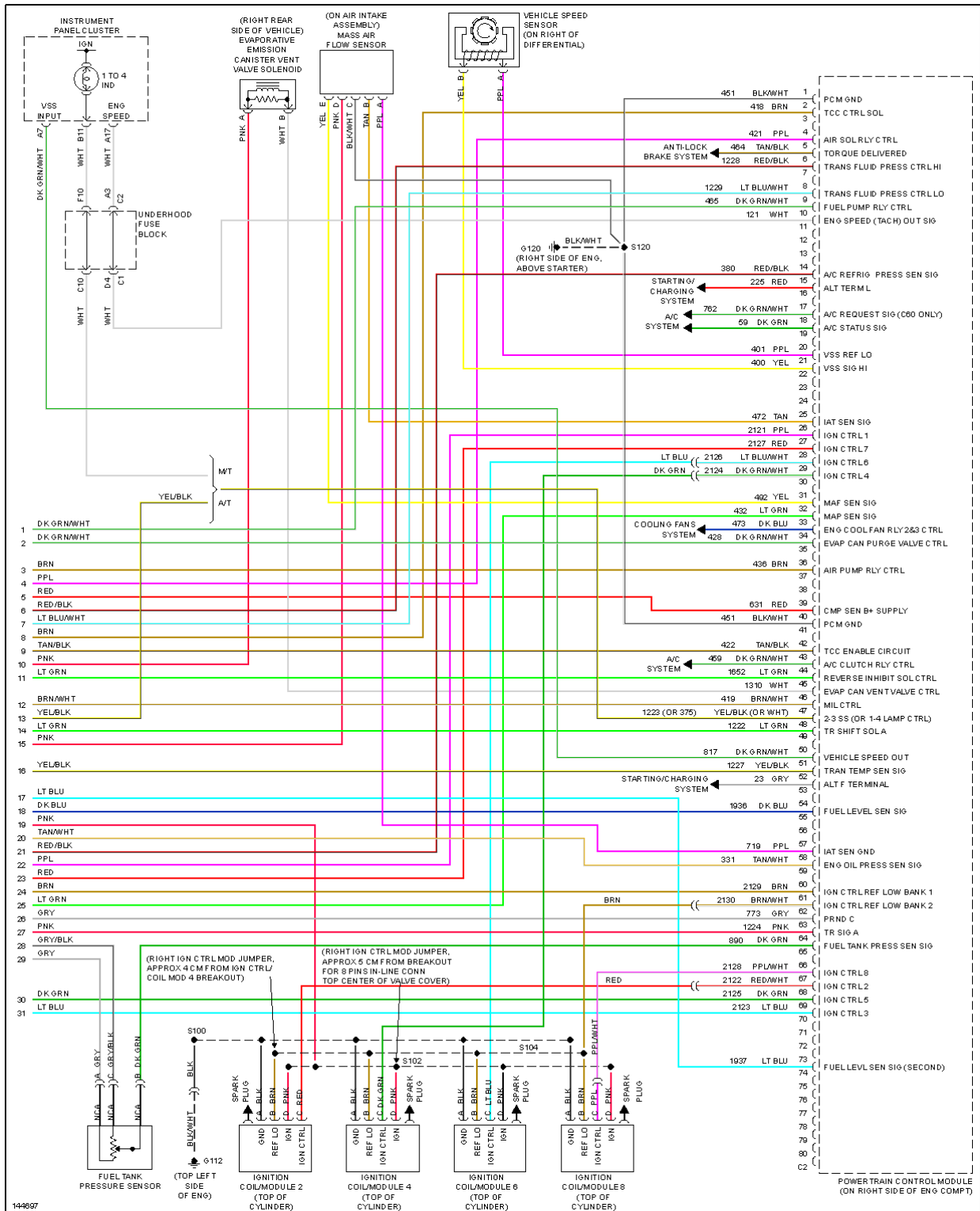

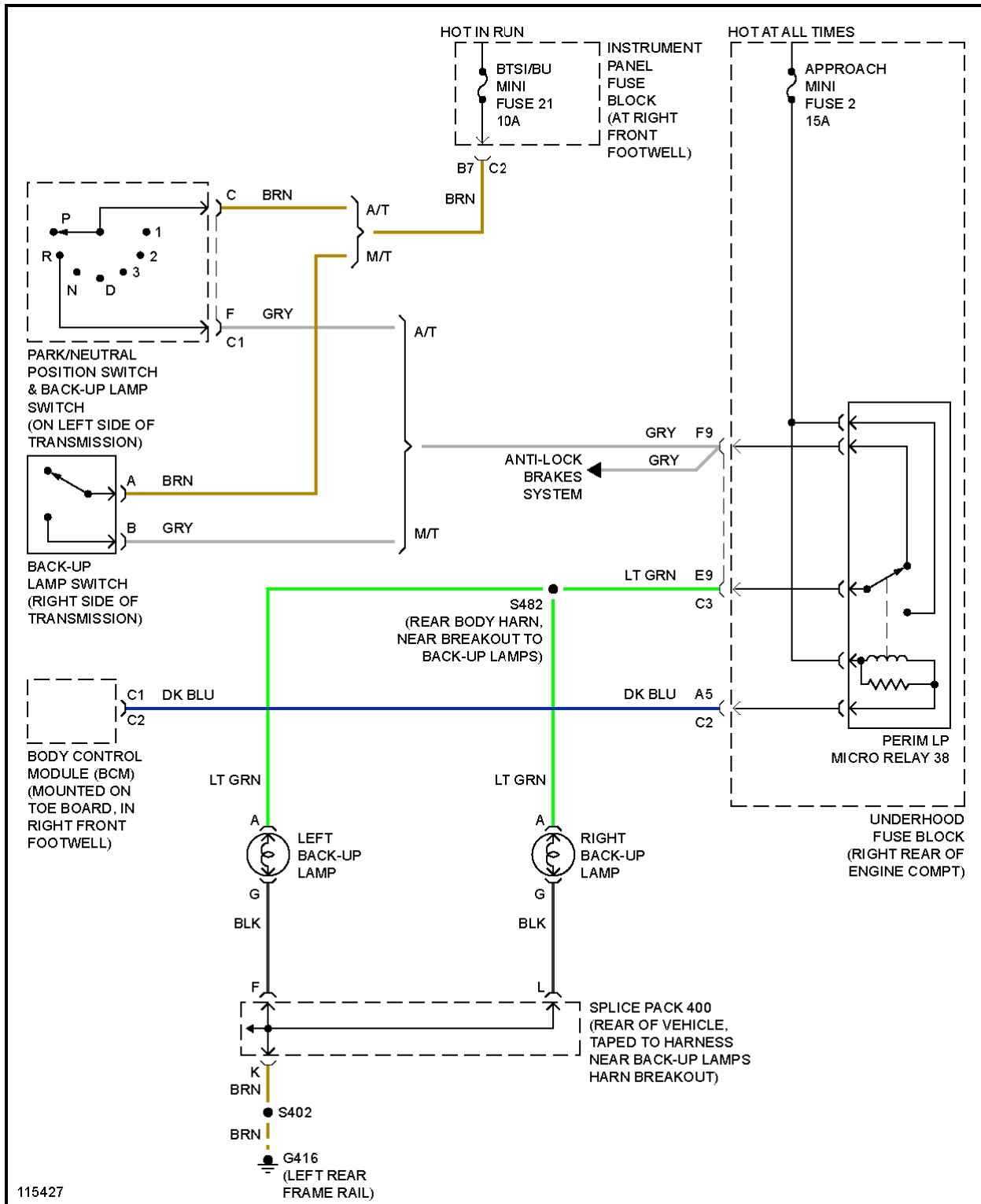

**Fig. 16: 5.7L VIN G, Engine Performance Circuits (4 of 4)**

**EXTERIOR LIGHTS**

# 2001 Chevrolet Corvette

## 2001 SYSTEM WIRING DIAGRAMS CHEVROLET Corvette



**Fig. 17: Back-up Lamps Circuit**

# 2001 Chevrolet Corvette

## 2001 SYSTEM WIRING DIAGRAMS CHEVROLET Corvette

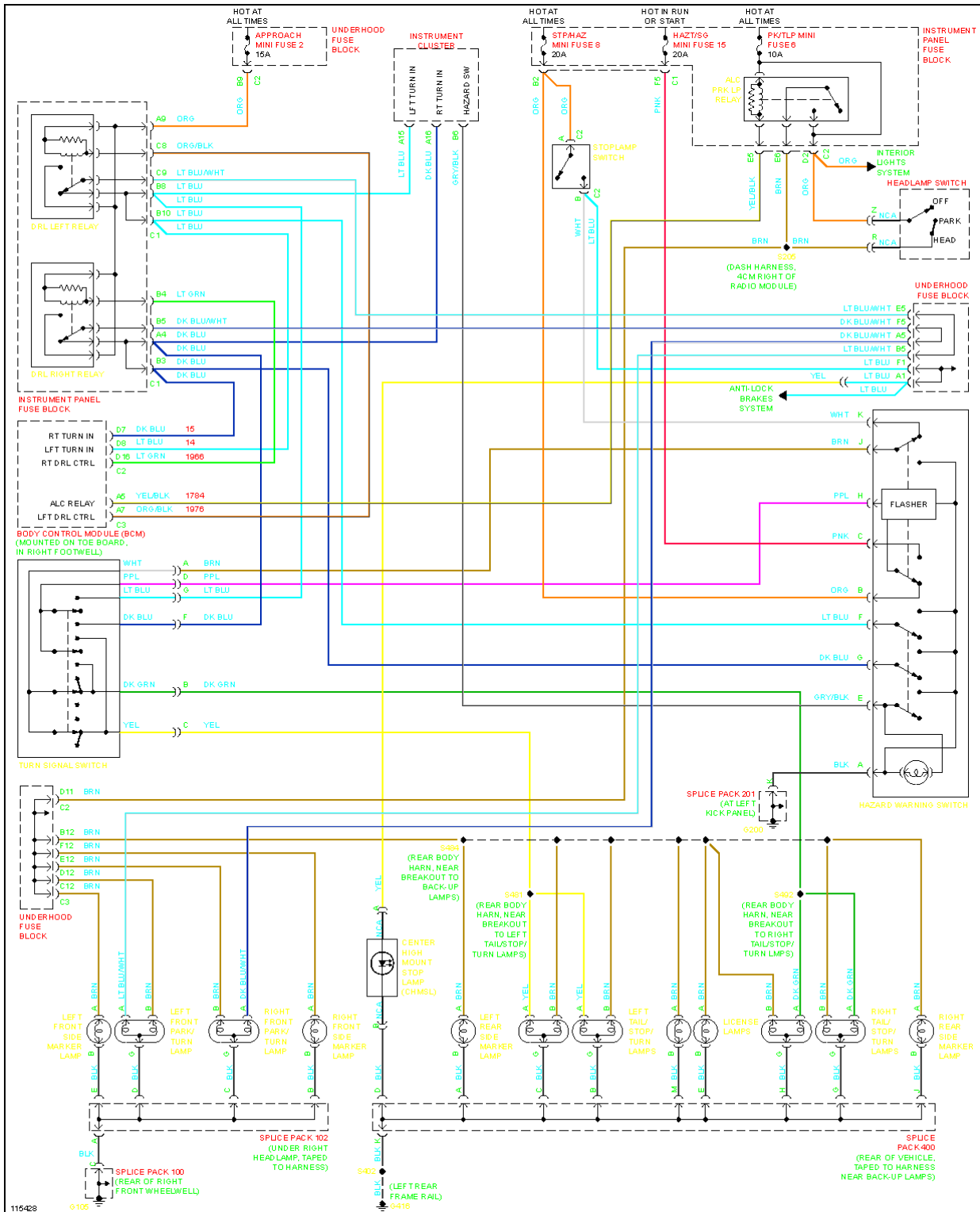
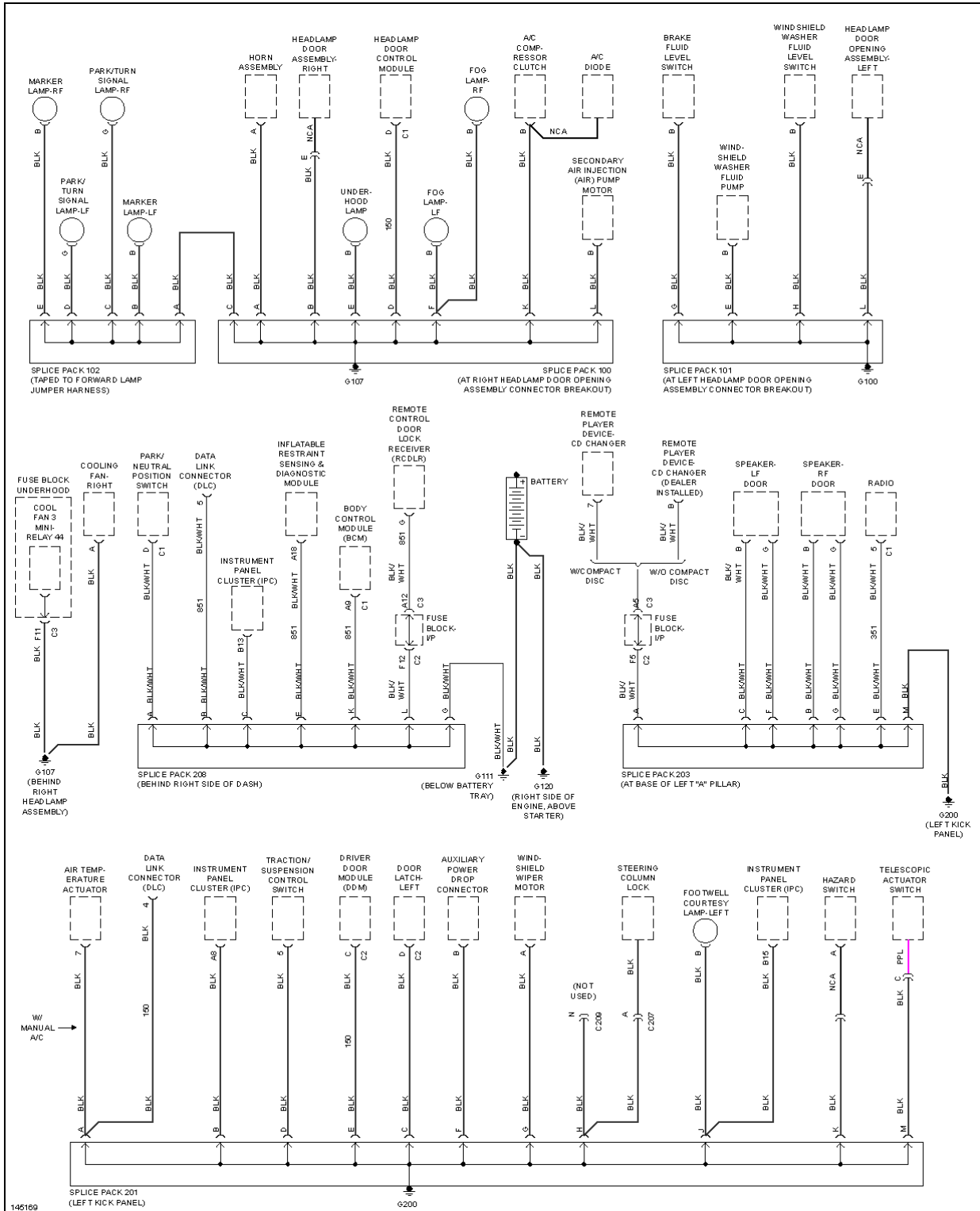

**Fig. 18: Exterior Lamps Circuit**

**GROUND DISTRIBUTION**

# 2001 Chevrolet Corvette

## 2001 SYSTEM WIRING DIAGRAMS CHEVROLET Corvette



**Fig. 19: Ground Distribution Circuit (1 of 3)**

# 2001 Chevrolet Corvette

## 2001 SYSTEM WIRING DIAGRAMS CHEVROLET Corvette

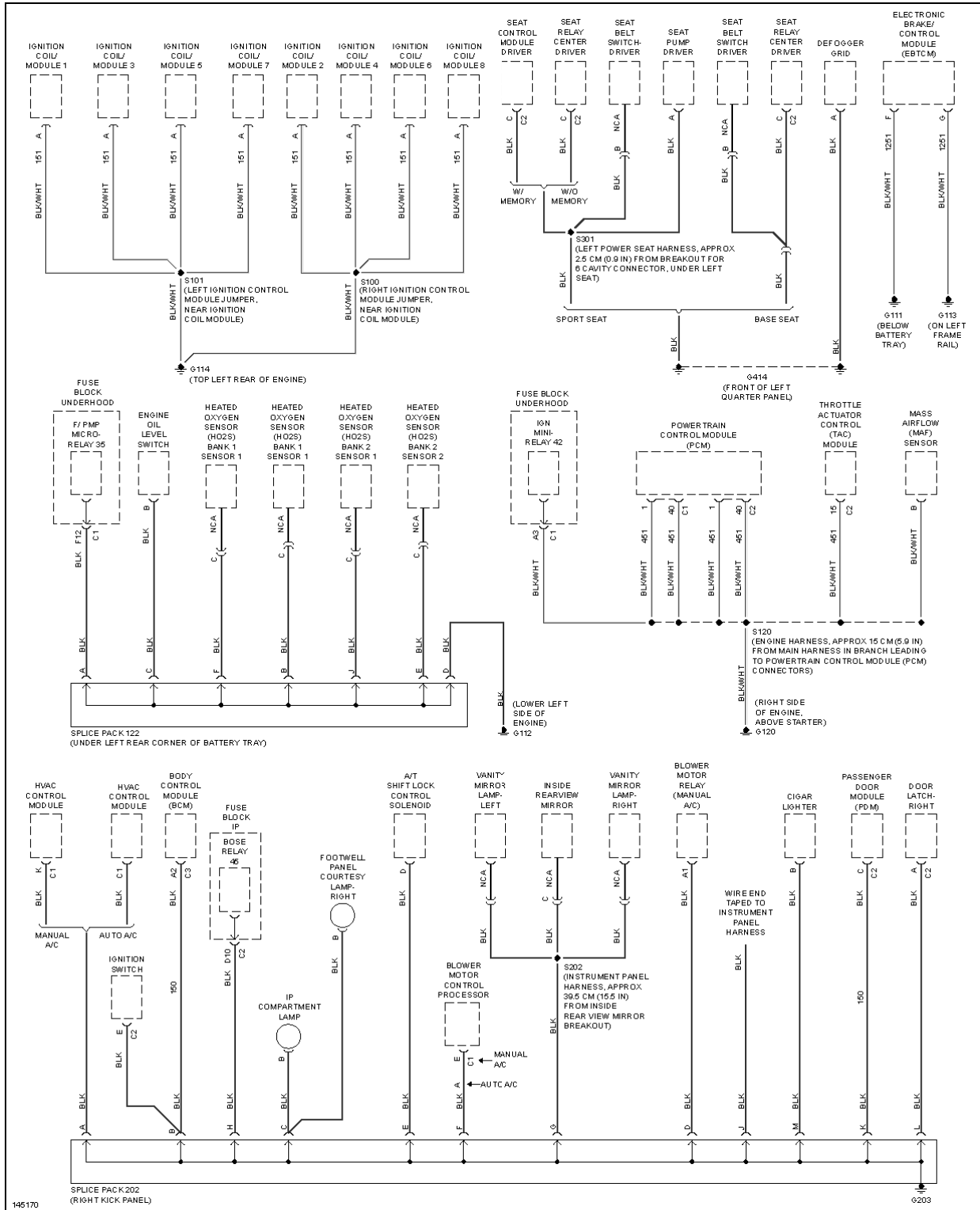
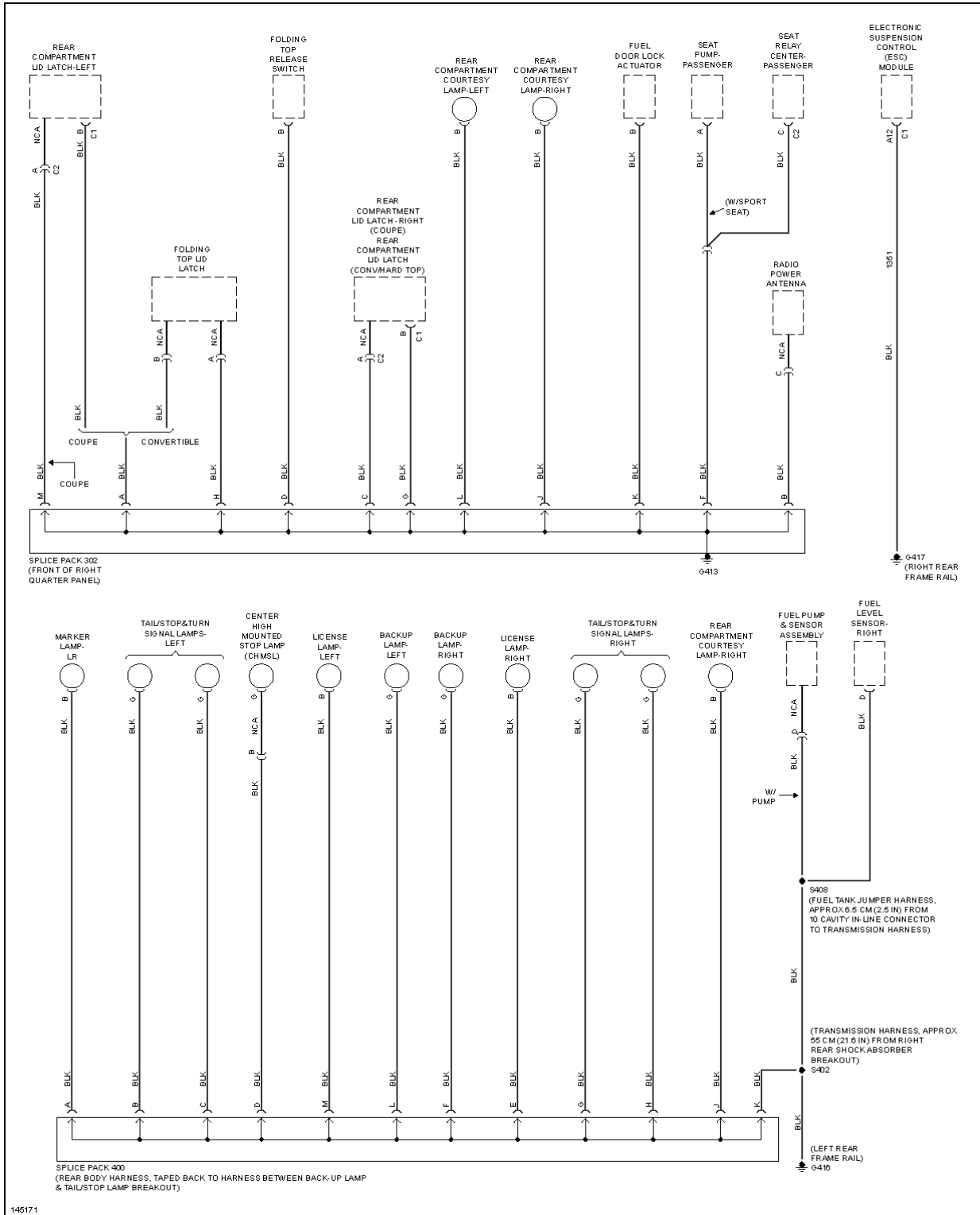



**Fig. 20: Ground Distribution Circuit (2 of 3)**

# 2001 Chevrolet Corvette

## 2001 SYSTEM WIRING DIAGRAMS CHEVROLET Corvette

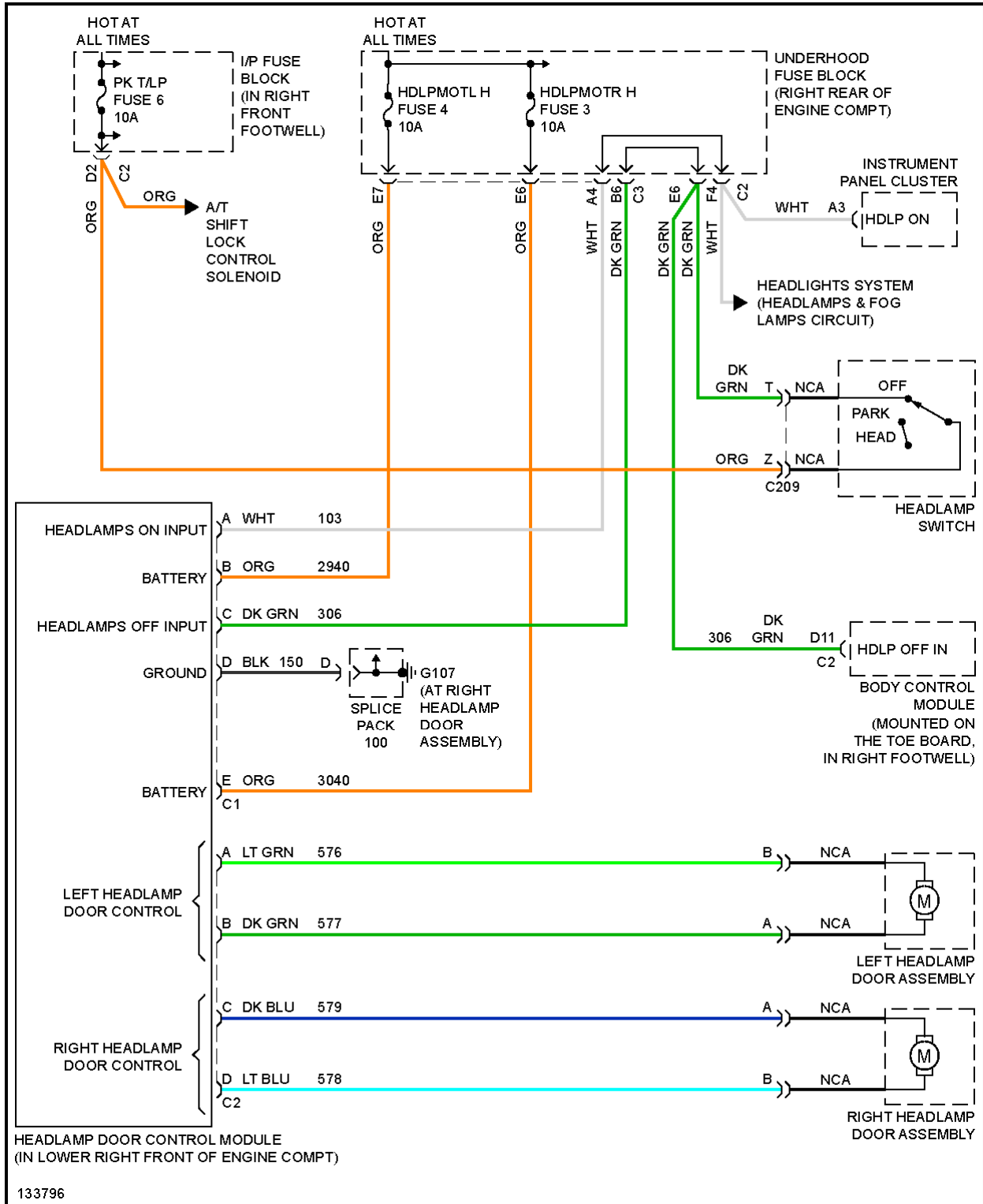

**Fig. 21: Ground Distribution Circuit (3 of 3)**

**HEADLIGHTS**

# 2001 Chevrolet Corvette

## 2001 SYSTEM WIRING DIAGRAMS CHEVROLET Corvette



**Fig. 22: Headlamp Doors Circuit**

# 2001 Chevrolet Corvette

## 2001 SYSTEM WIRING DIAGRAMS CHEVROLET Corvette

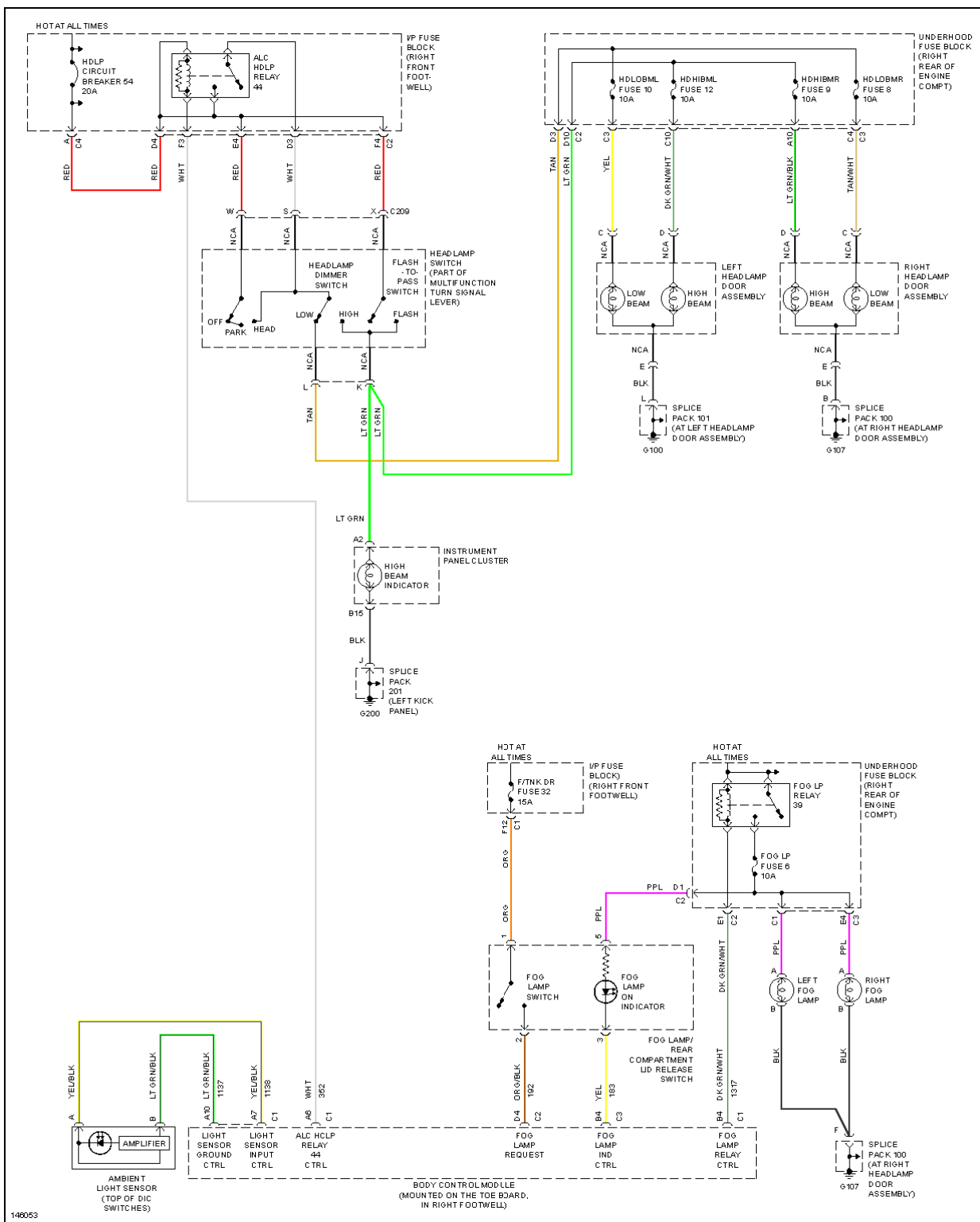
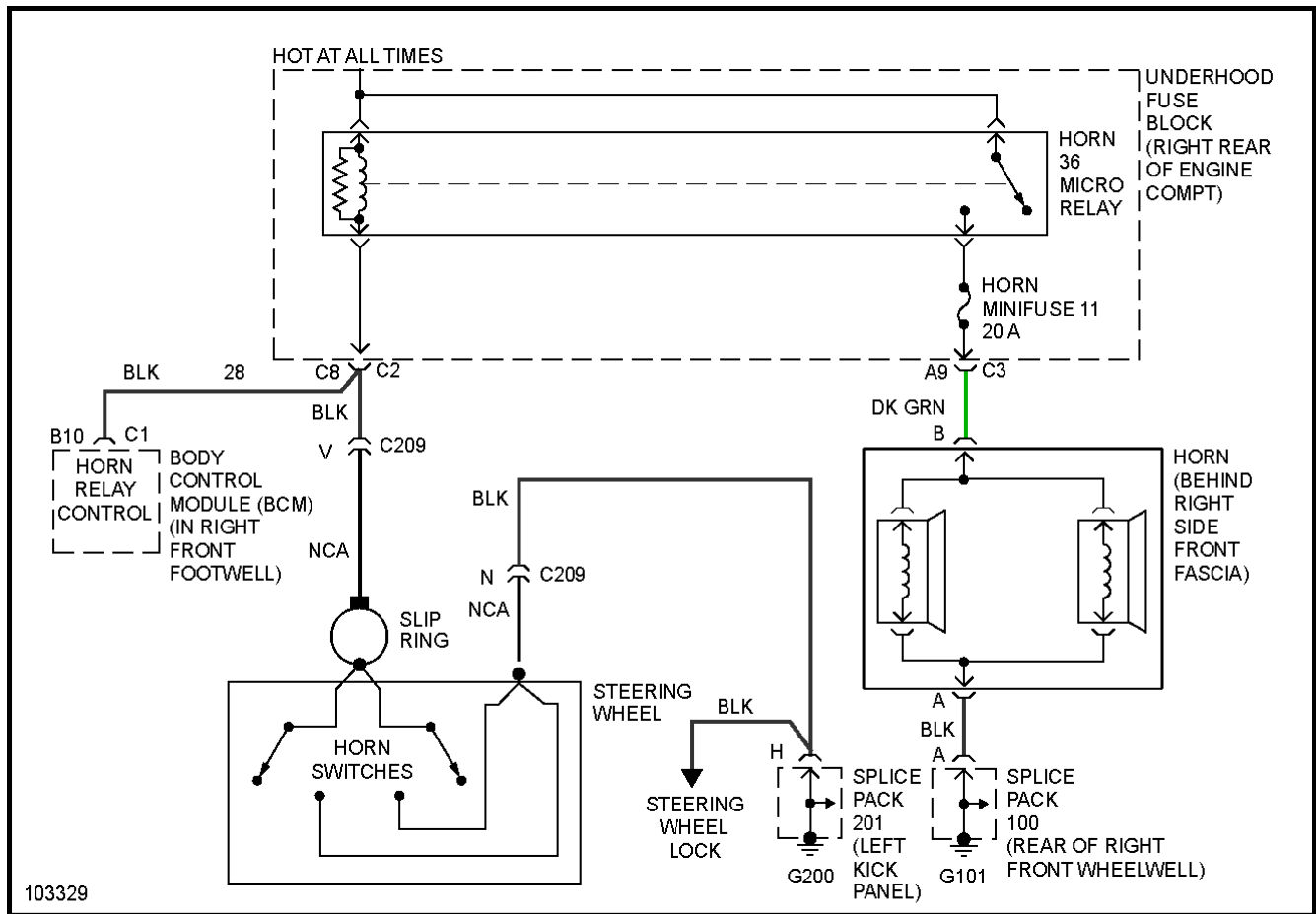

**Fig. 23: Headlight Circuit**

**HORN**

# 2001 Chevrolet Corvette

## 2001 SYSTEM WIRING DIAGRAMS CHEVROLET Corvette



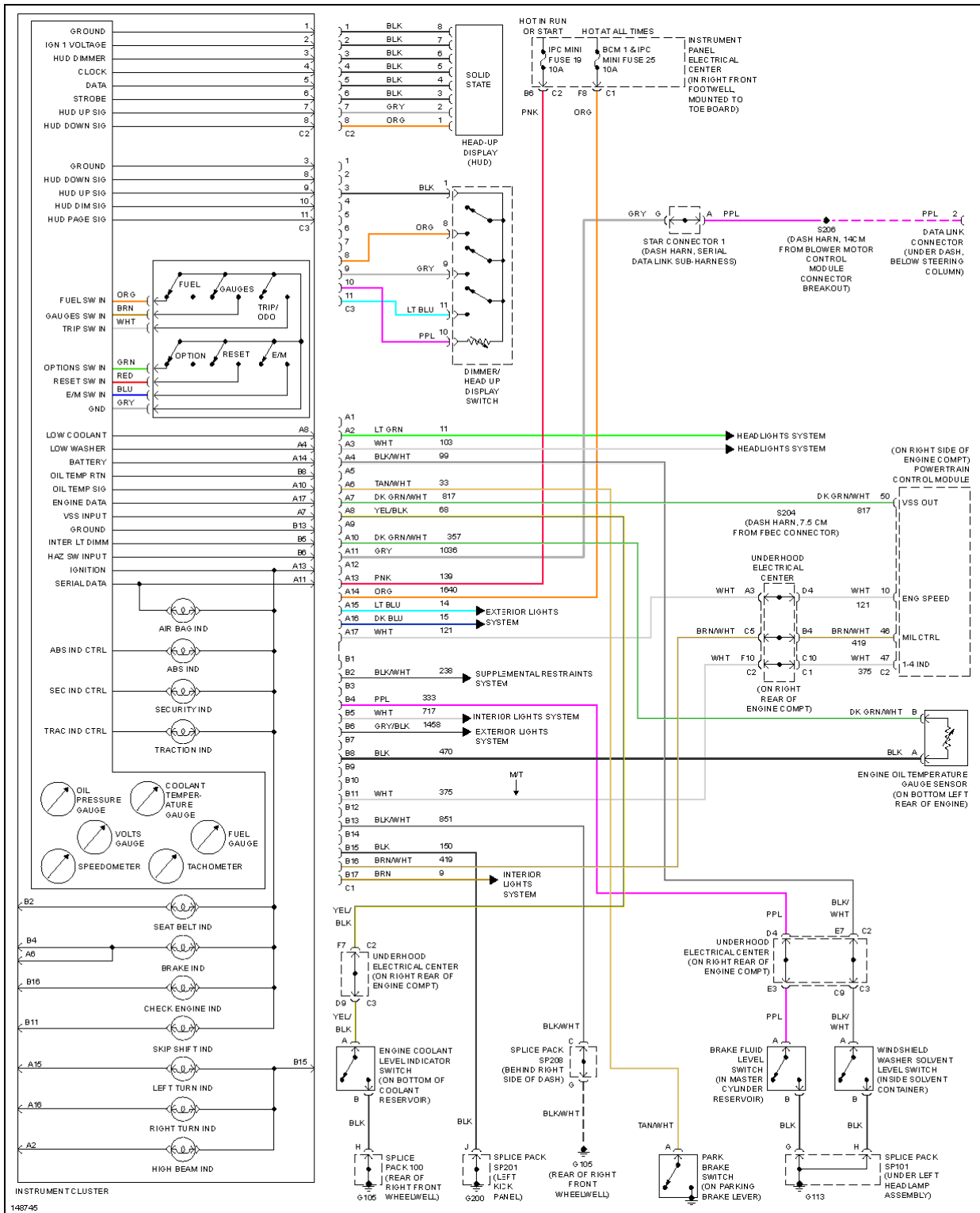

**Fig. 24: Horn Circuit**

**INSTRUMENT CLUSTER**

# 2001 Chevrolet Corvette

## 2001 SYSTEM WIRING DIAGRAMS CHEVROLET Corvette

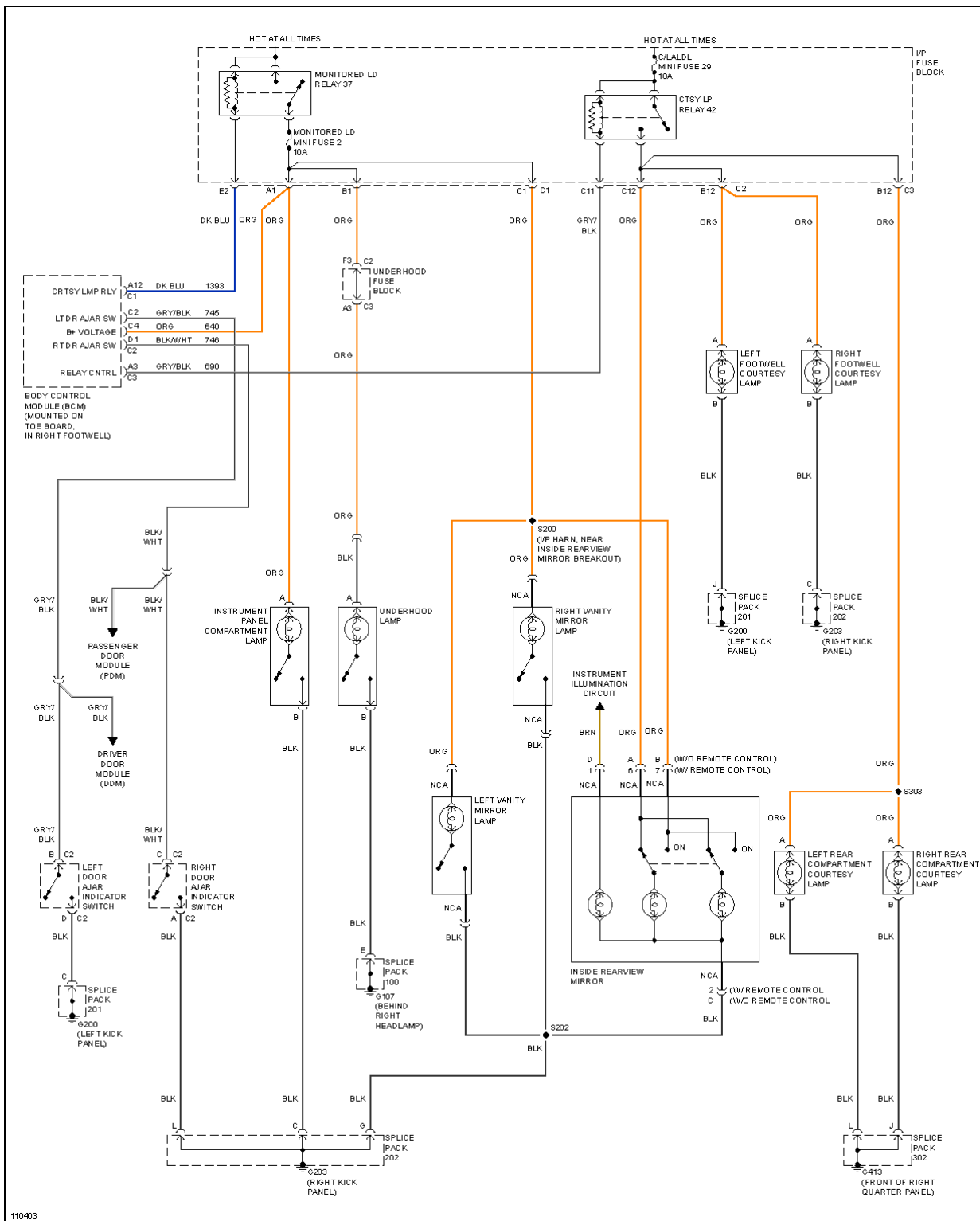

**Fig. 25: Instrument Cluster Circuit**

**INTERIOR LIGHTS**

# 2001 Chevrolet Corvette

## 2001 SYSTEM WIRING DIAGRAMS CHEVROLET Corvette



**Fig. 26: Courtesy Lamps Circuit**

# 2001 Chevrolet Corvette

## 2001 SYSTEM WIRING DIAGRAMS CHEVROLET Corvette

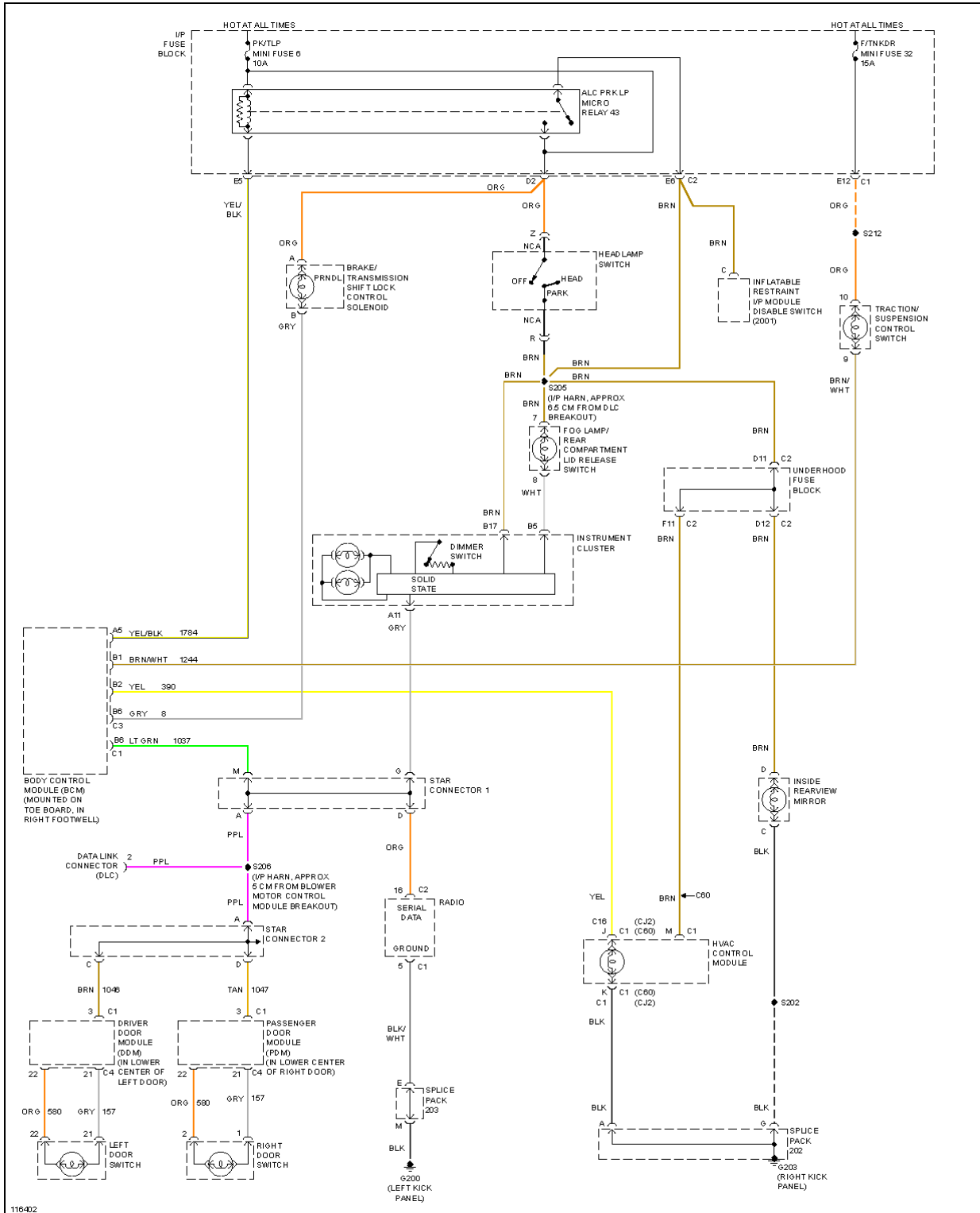
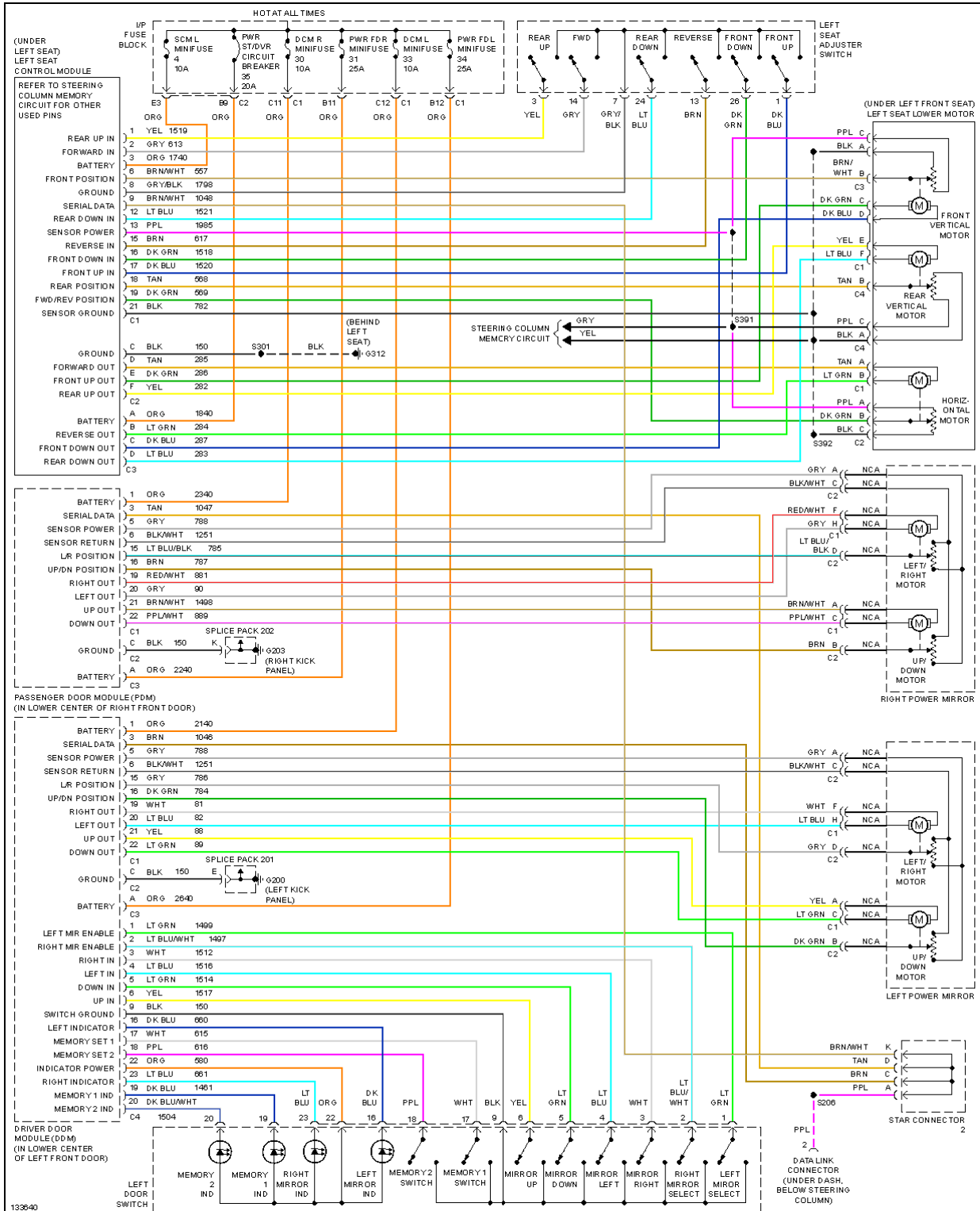

**Fig. 27: Instrument Illumination Circuit**

**MEMORY SYSTEMS**

# 2001 Chevrolet Corvette

## 2001 SYSTEM WIRING DIAGRAMS CHEVROLET Corvette





**2001 Chevrolet Corvette**

2001 SYSTEM WIRING DIAGRAMS CHEVROLET Corvette

**Fig. 28: Memory Seat & Mirrors Circuit**

# 2001 Chevrolet Corvette

## 2001 SYSTEM WIRING DIAGRAMS CHEVROLET Corvette

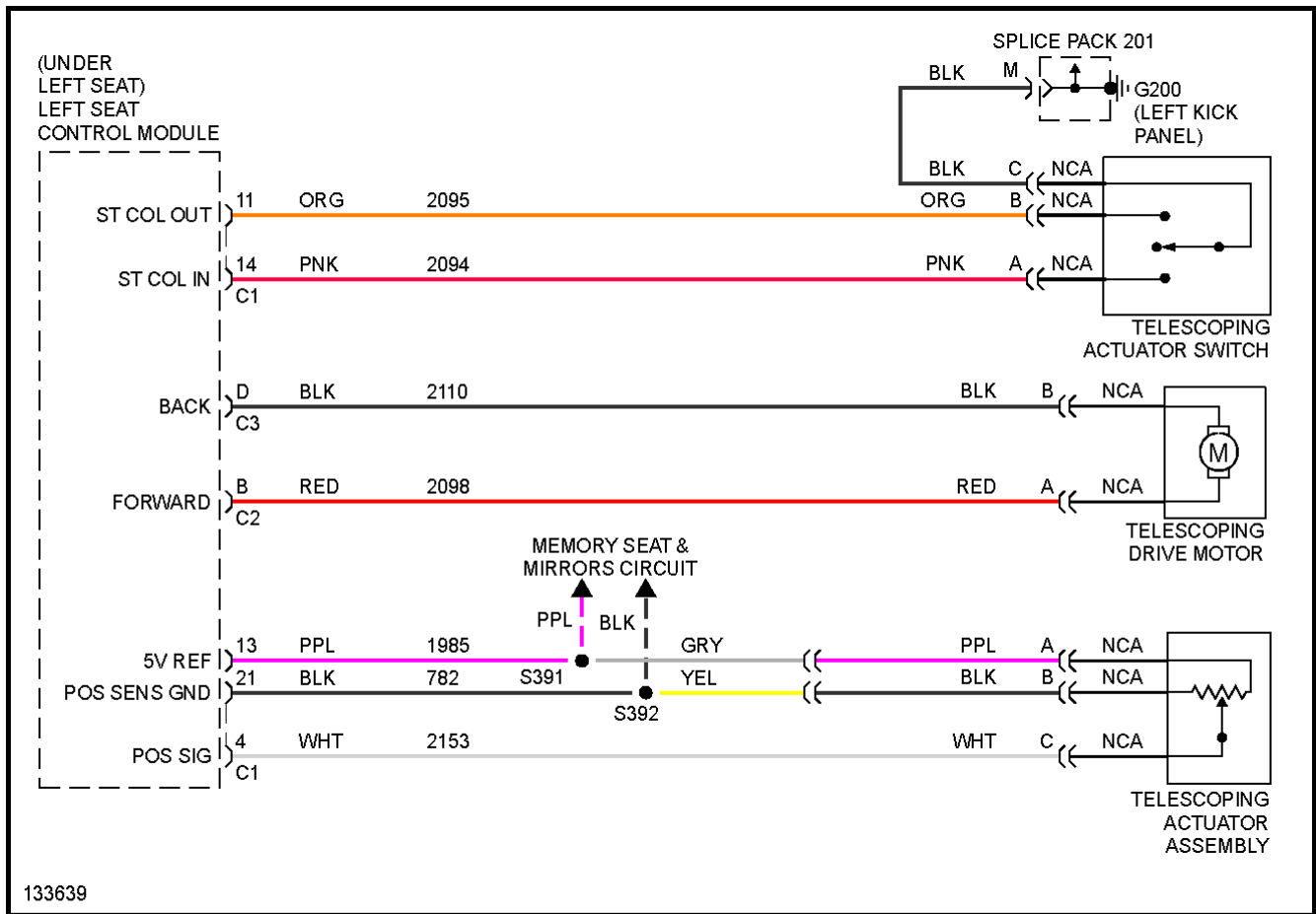
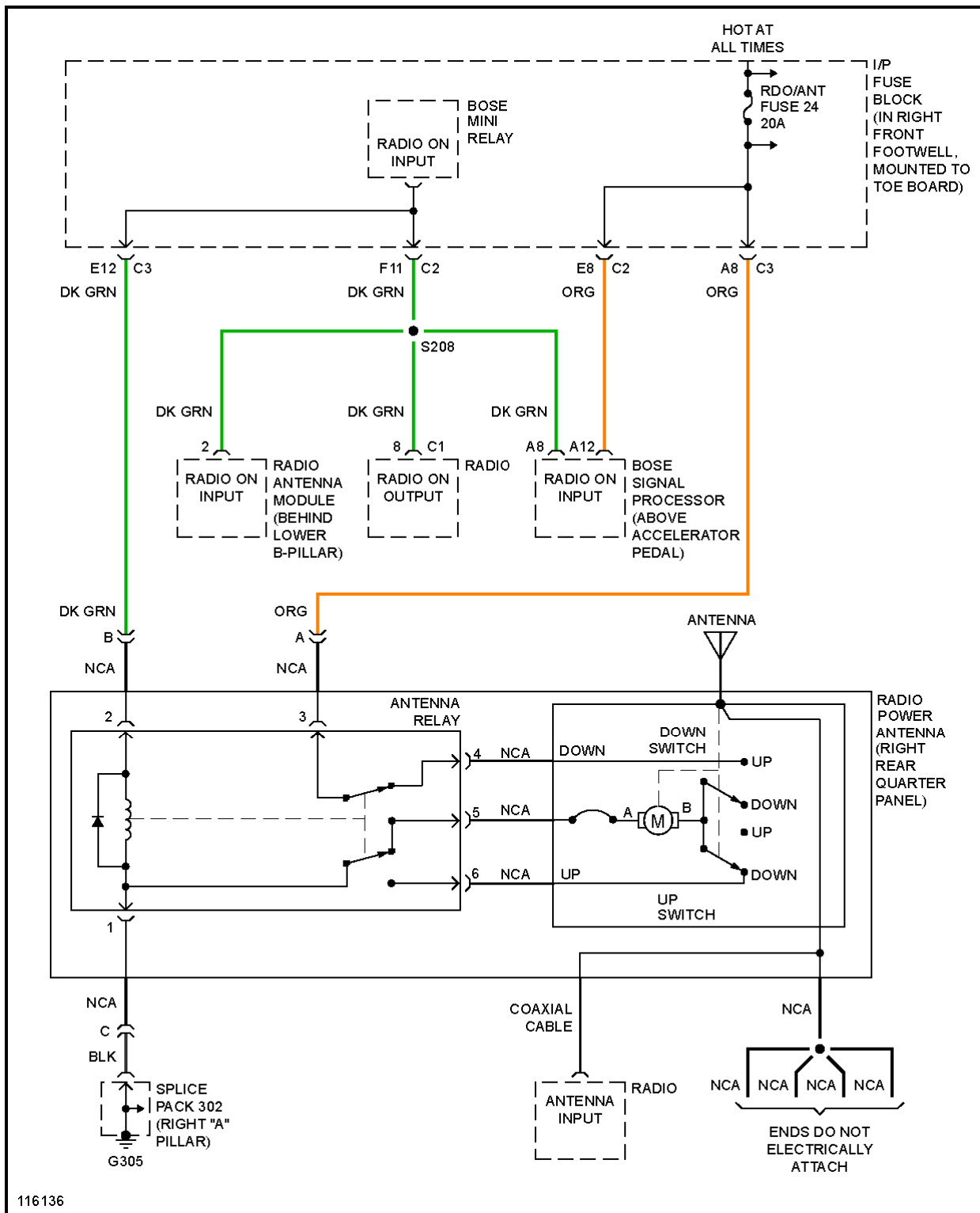

**Fig. 29: Steering Column Memory Circuit**

**POWER ANTENNA**

# 2001 Chevrolet Corvette

## 2001 SYSTEM WIRING DIAGRAMS CHEVROLET Corvette

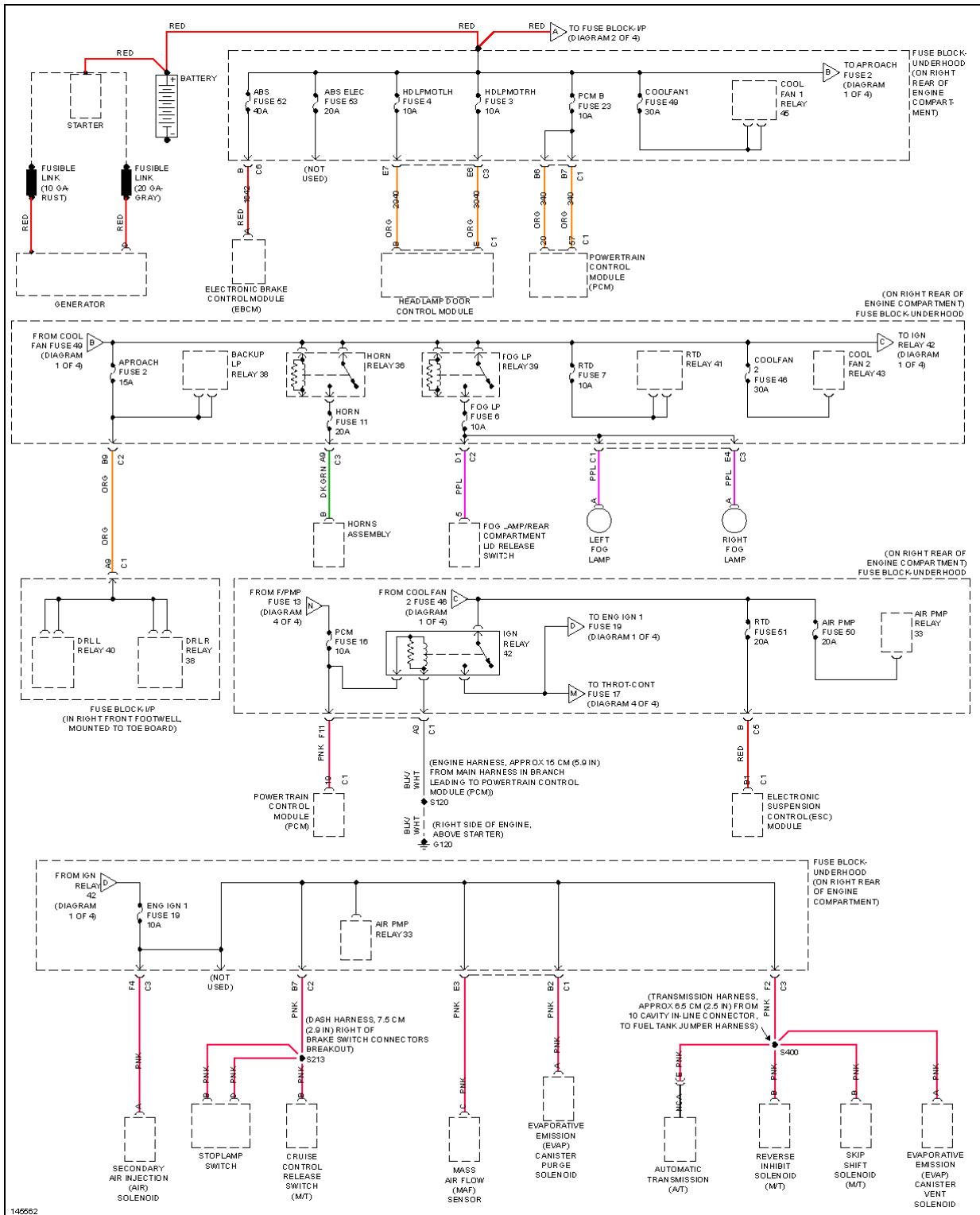

**Fig. 30: Power Antenna Circuit**

**POWER DISTRIBUTION**

# 2001 Chevrolet Corvette

## 2001 SYSTEM WIRING DIAGRAMS CHEVROLET Corvette



**Fig. 31: Power Distribution Circuit (1 of 4)**

# 2001 Chevrolet Corvette

## 2001 SYSTEM WIRING DIAGRAMS CHEVROLET Corvette

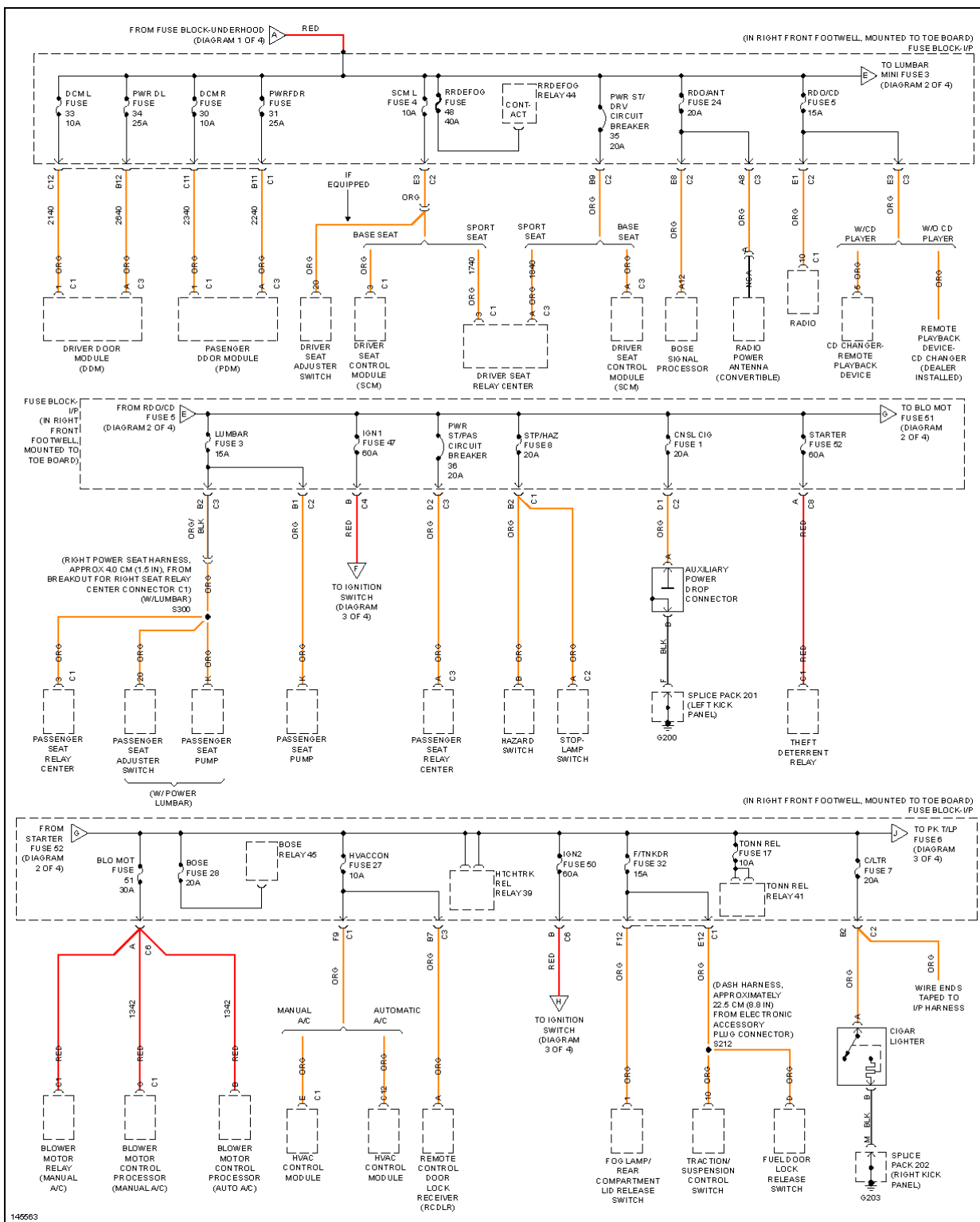
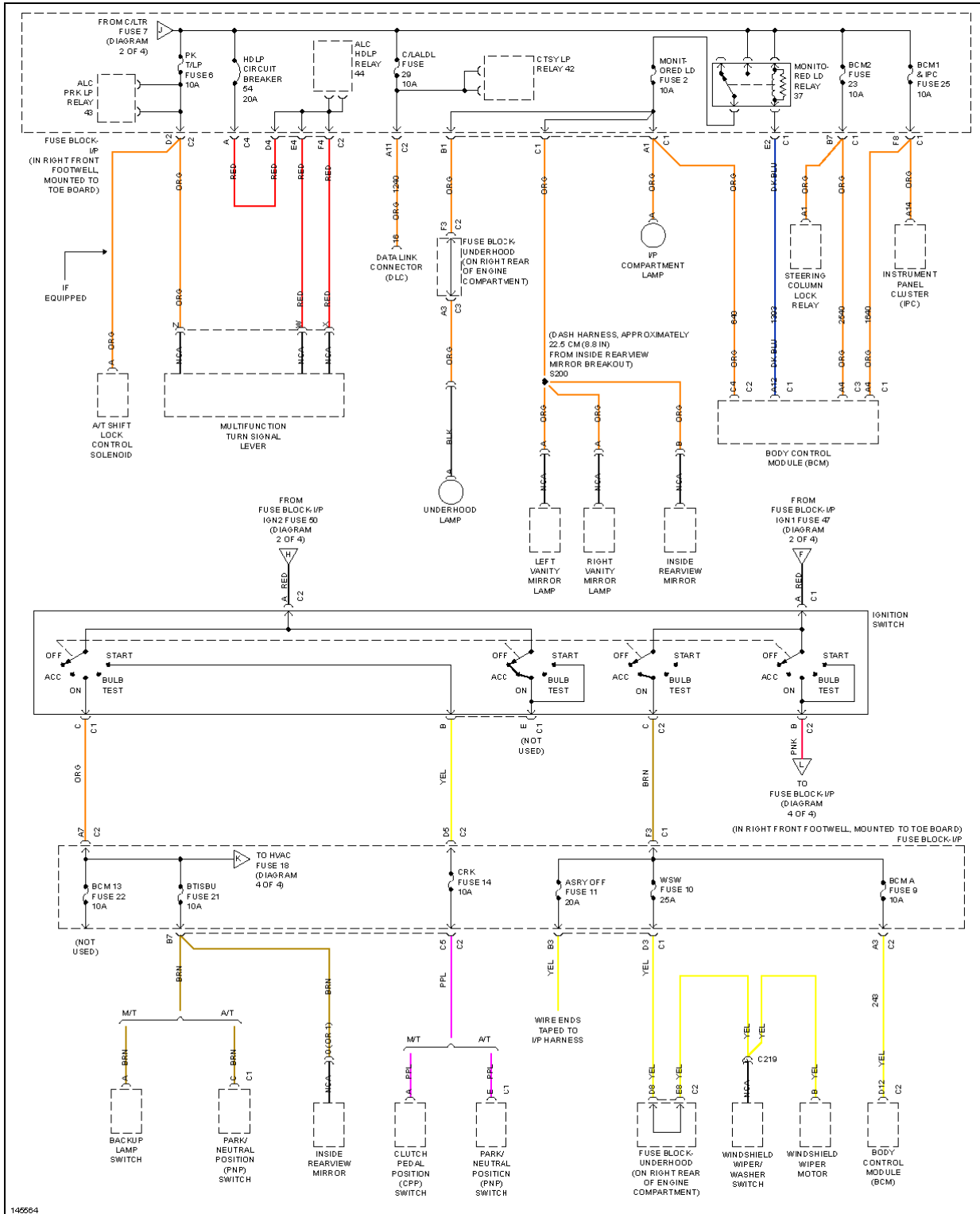



**Fig. 32: Power Distribution Circuit (2 of 4)**

# 2001 Chevrolet Corvette

## 2001 SYSTEM WIRING DIAGRAMS CHEVROLET Corvette



**Fig. 33: Power Distribution Circuit (3 of 4)**

# 2001 Chevrolet Corvette

## 2001 SYSTEM WIRING DIAGRAMS CHEVROLET Corvette

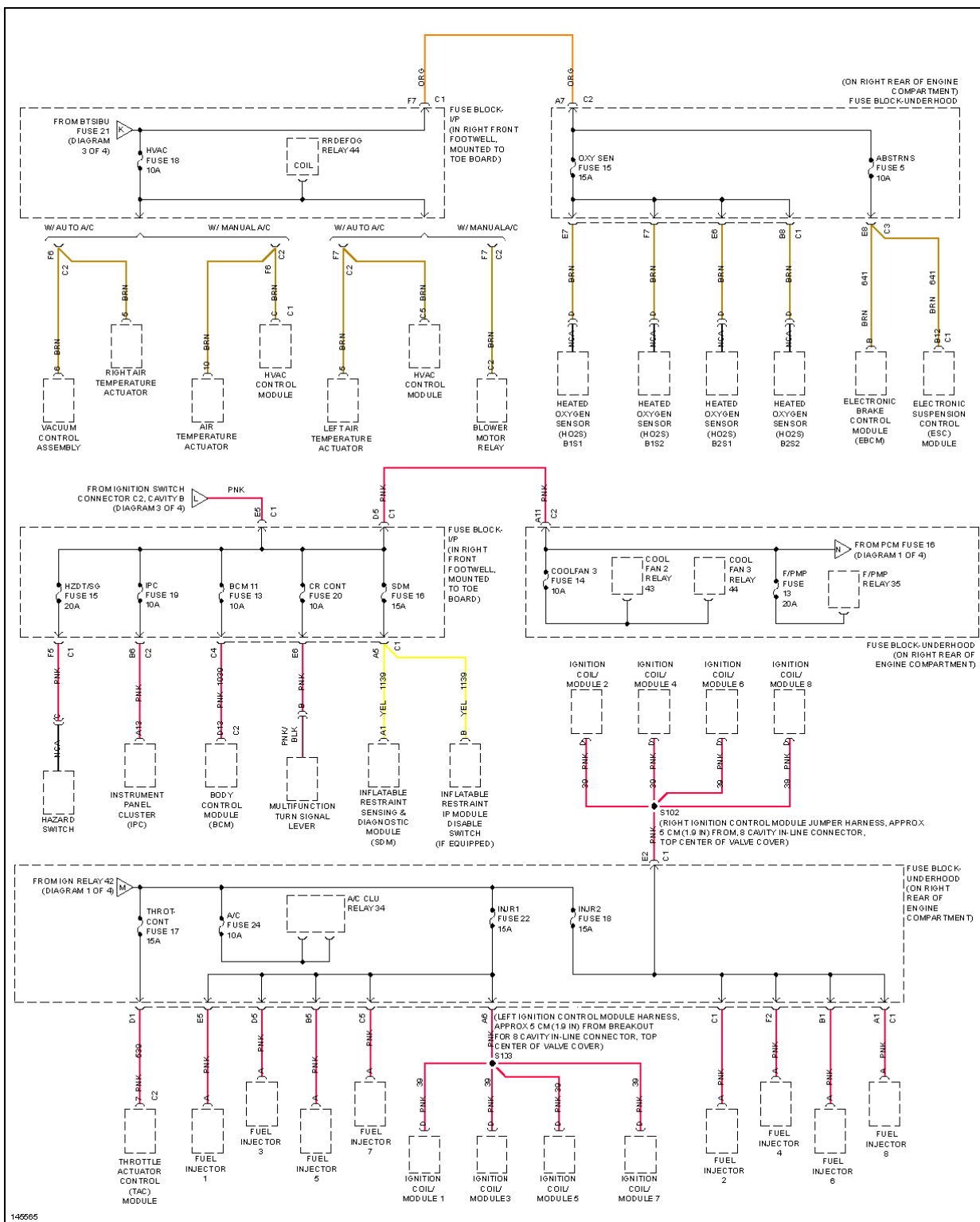
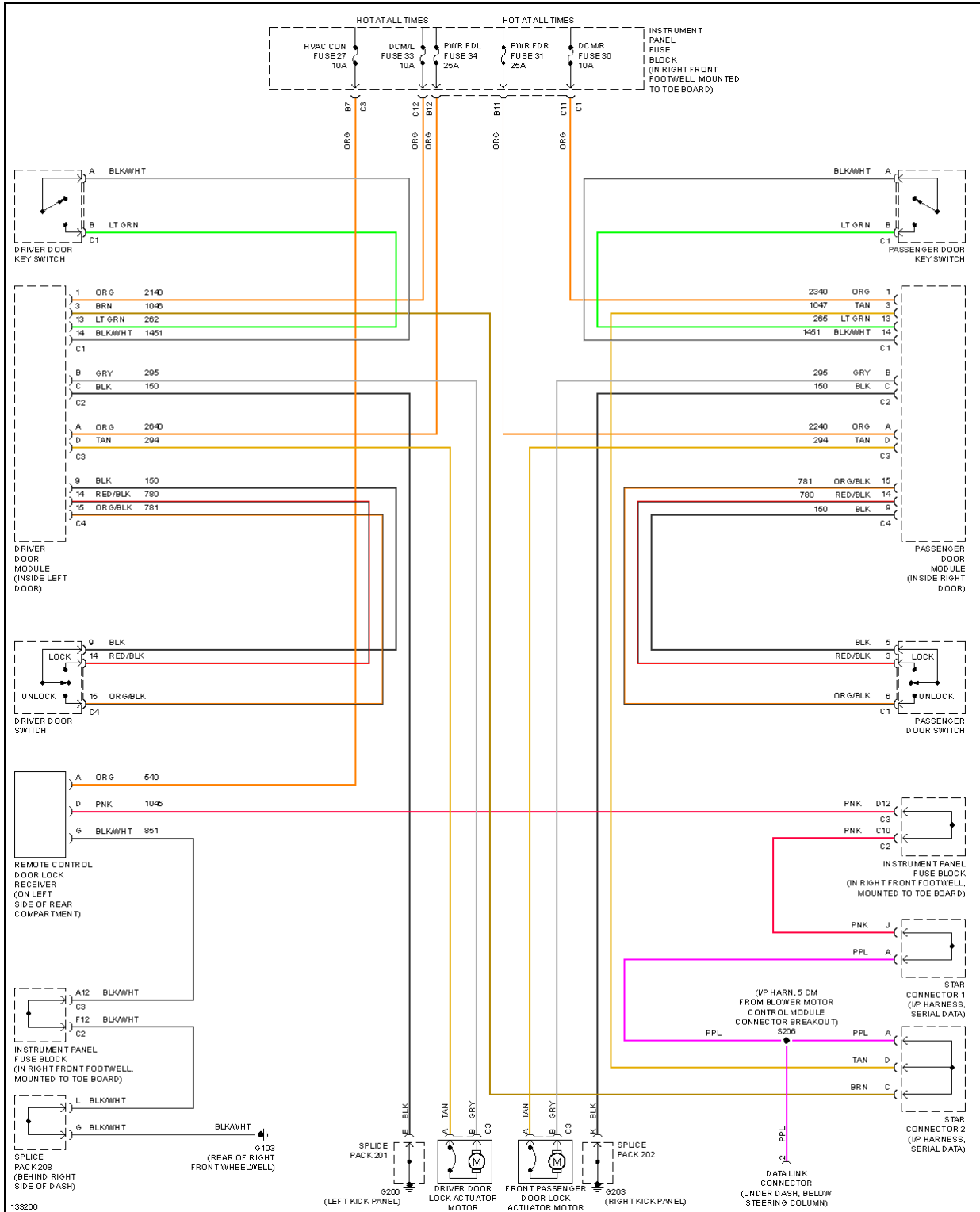

**Fig. 34: Power Distribution Circuit (4 of 4)**

**POWER DOOR LOCKS**

# 2001 Chevrolet Corvette

## 2001 SYSTEM WIRING DIAGRAMS CHEVROLET Corvette

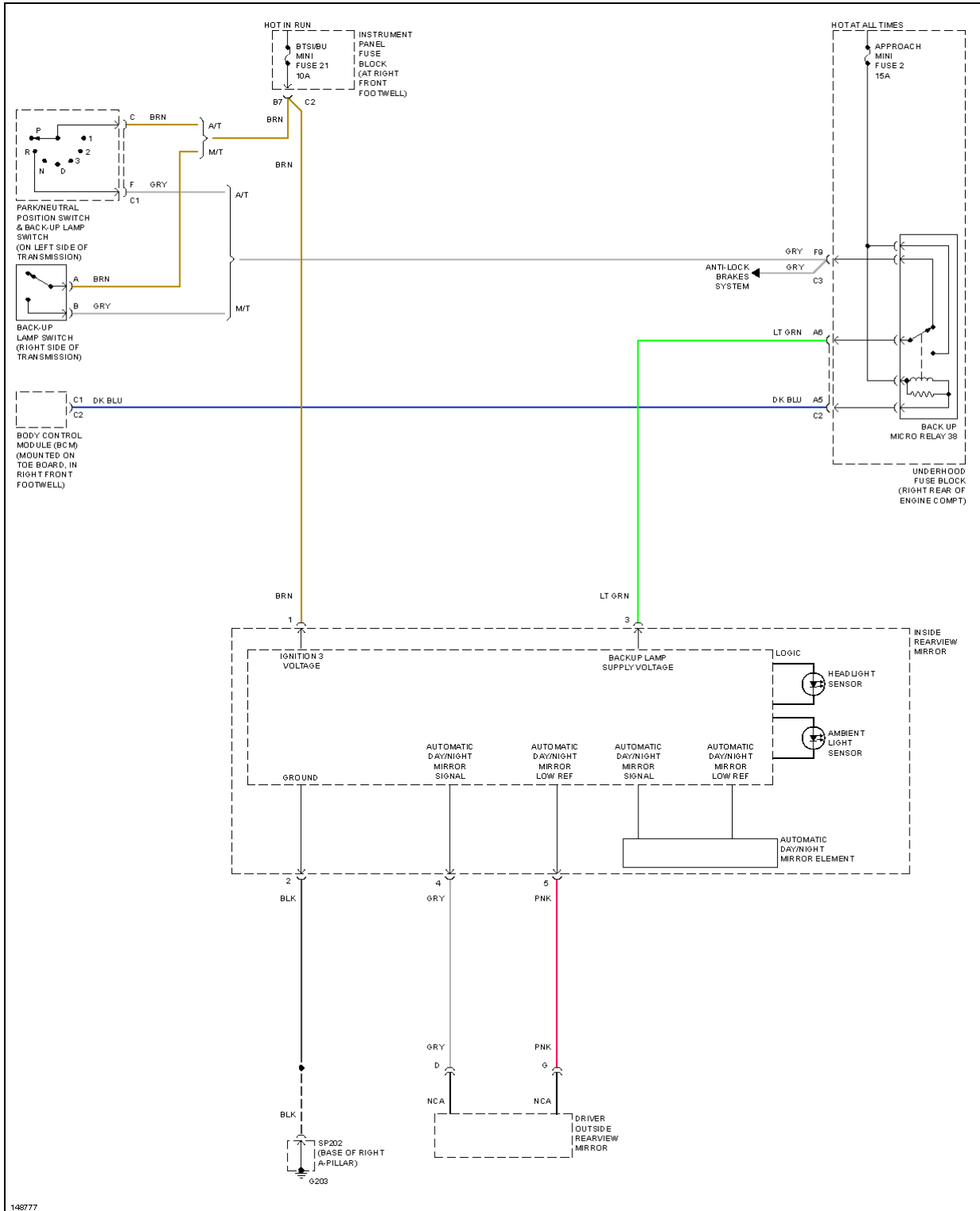

**Fig. 35: Power Door Lock Circuit**

**POWER MIRRORS**

# 2001 Chevrolet Corvette

## 2001 SYSTEM WIRING DIAGRAMS CHEVROLET Corvette

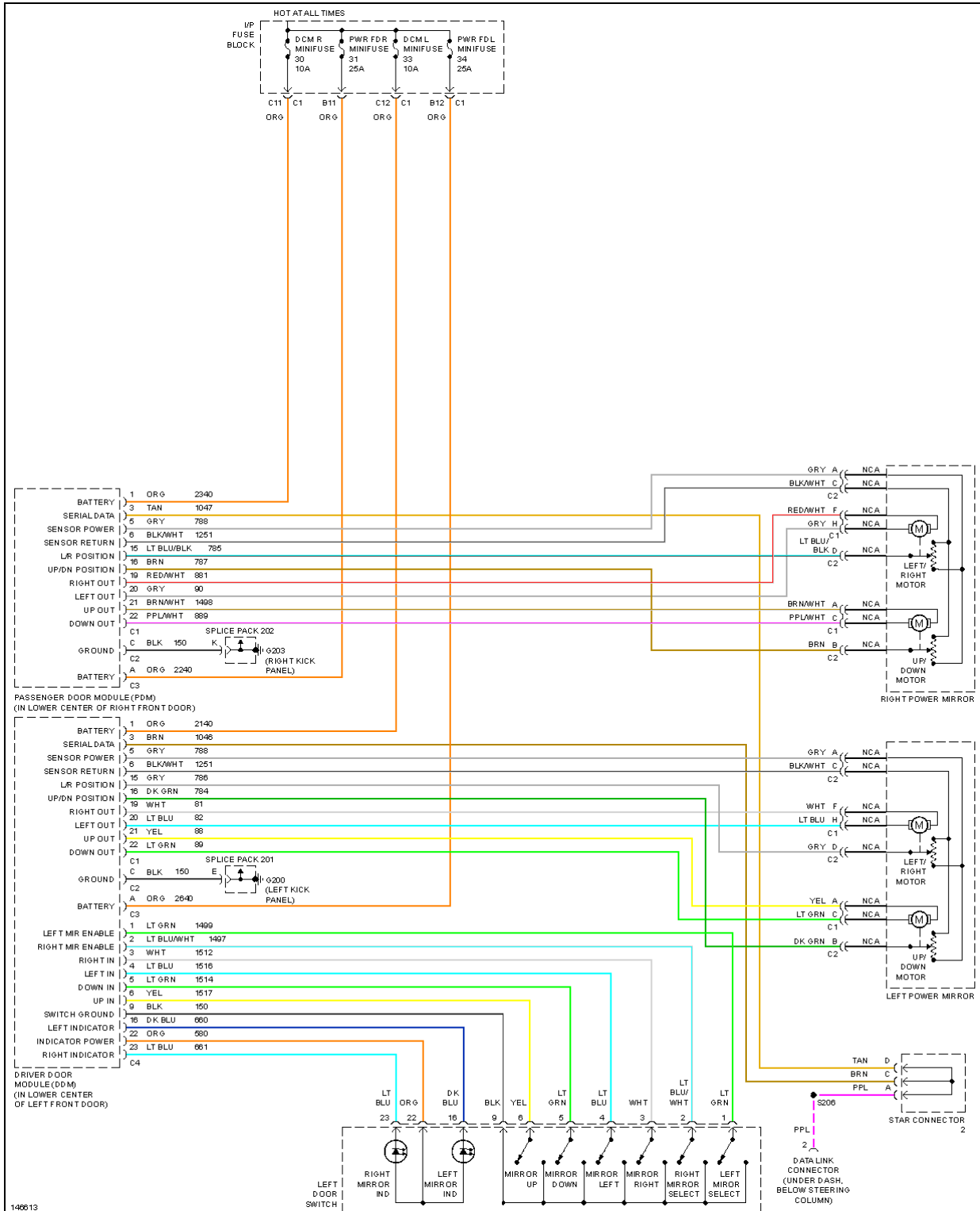



**Fig. 36: Electronic Day/Night Mirror Circuit**

# 2001 Chevrolet Corvette

## 2001 SYSTEM WIRING DIAGRAMS CHEVROLET Corvette

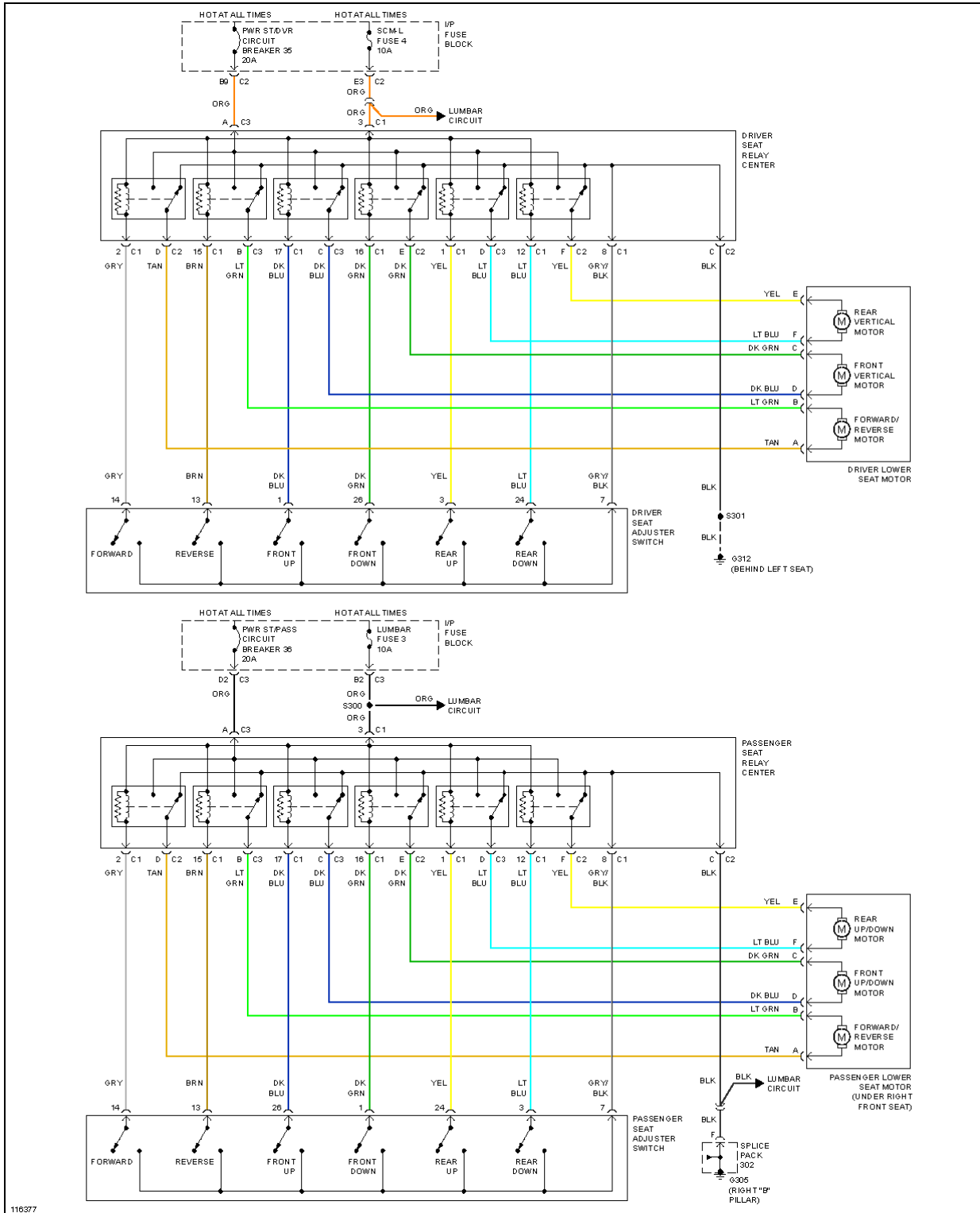

**Fig. 37: Power Mirror Circuit**

**POWER SEATS**

# 2001 Chevrolet Corvette

## 2001 SYSTEM WIRING DIAGRAMS CHEVROLET Corvette



**2001 Chevrolet Corvette**

2001 SYSTEM WIRING DIAGRAMS CHEVROLET Corvette

**Fig. 38: 6-Way Power Seat Circuit**

# 2001 Chevrolet Corvette

## 2001 SYSTEM WIRING DIAGRAMS CHEVROLET Corvette

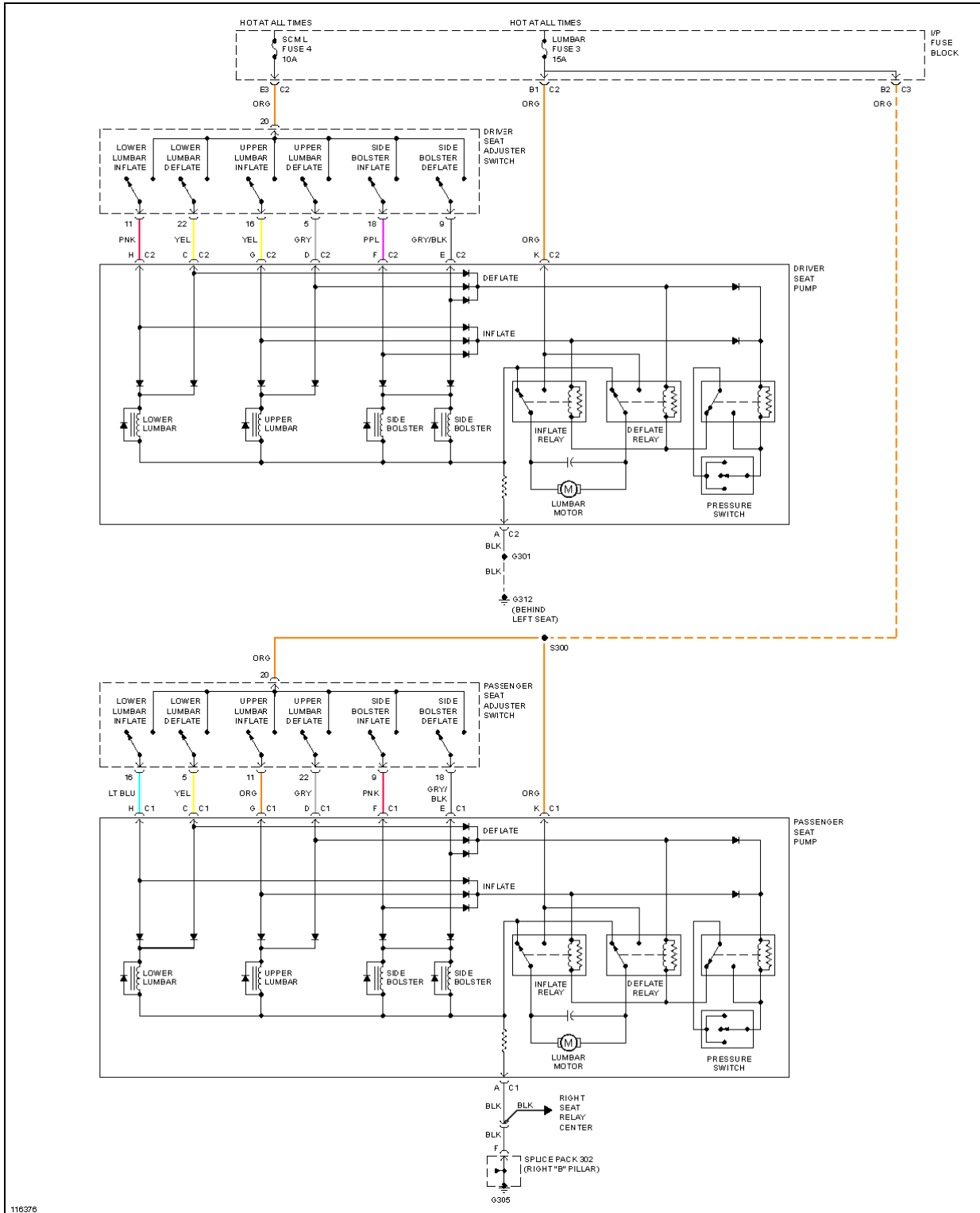
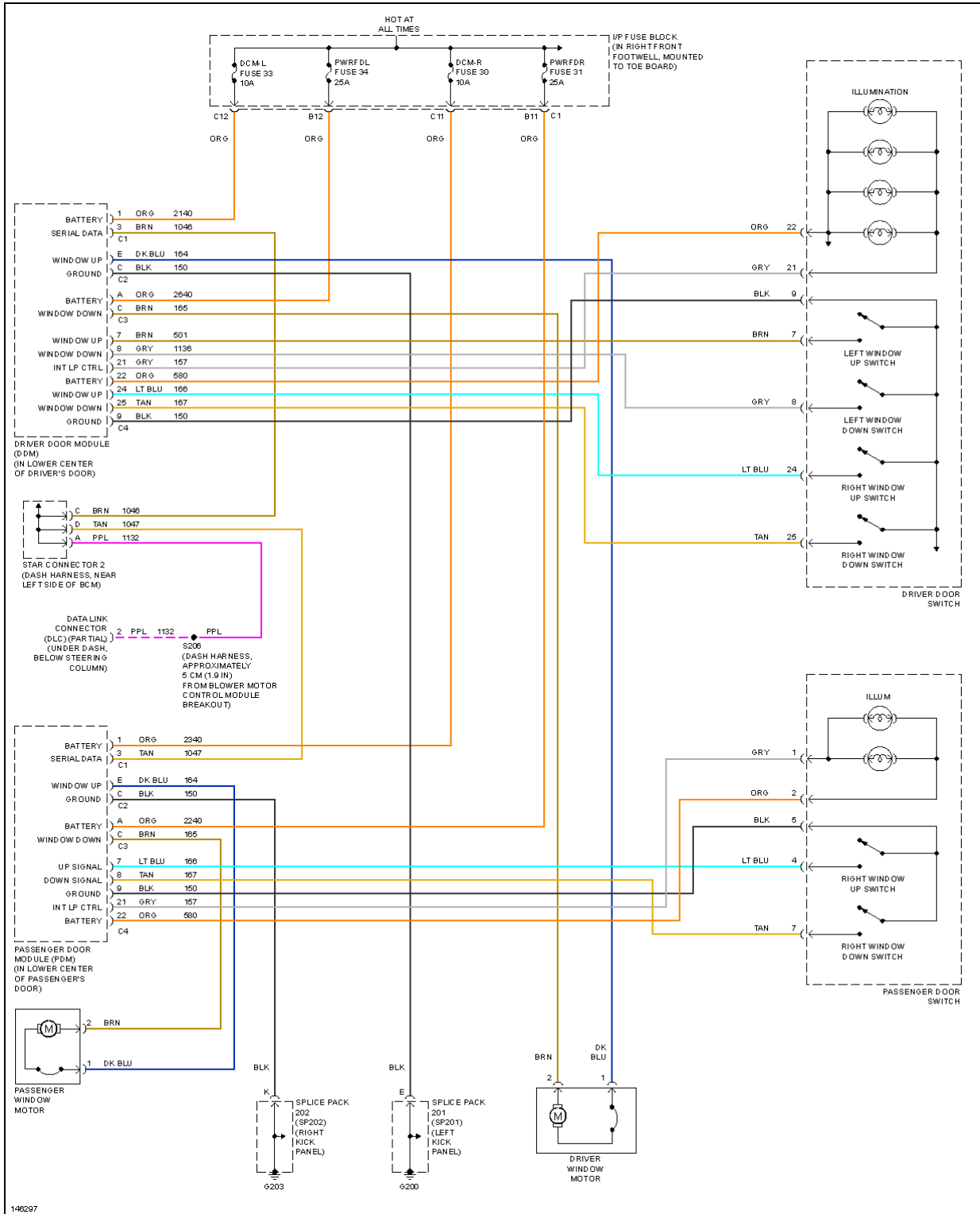

**Fig. 39: Lumbar Circuit**

**POWER WINDOWS**

# 2001 Chevrolet Corvette

## 2001 SYSTEM WIRING DIAGRAMS CHEVROLET Corvette



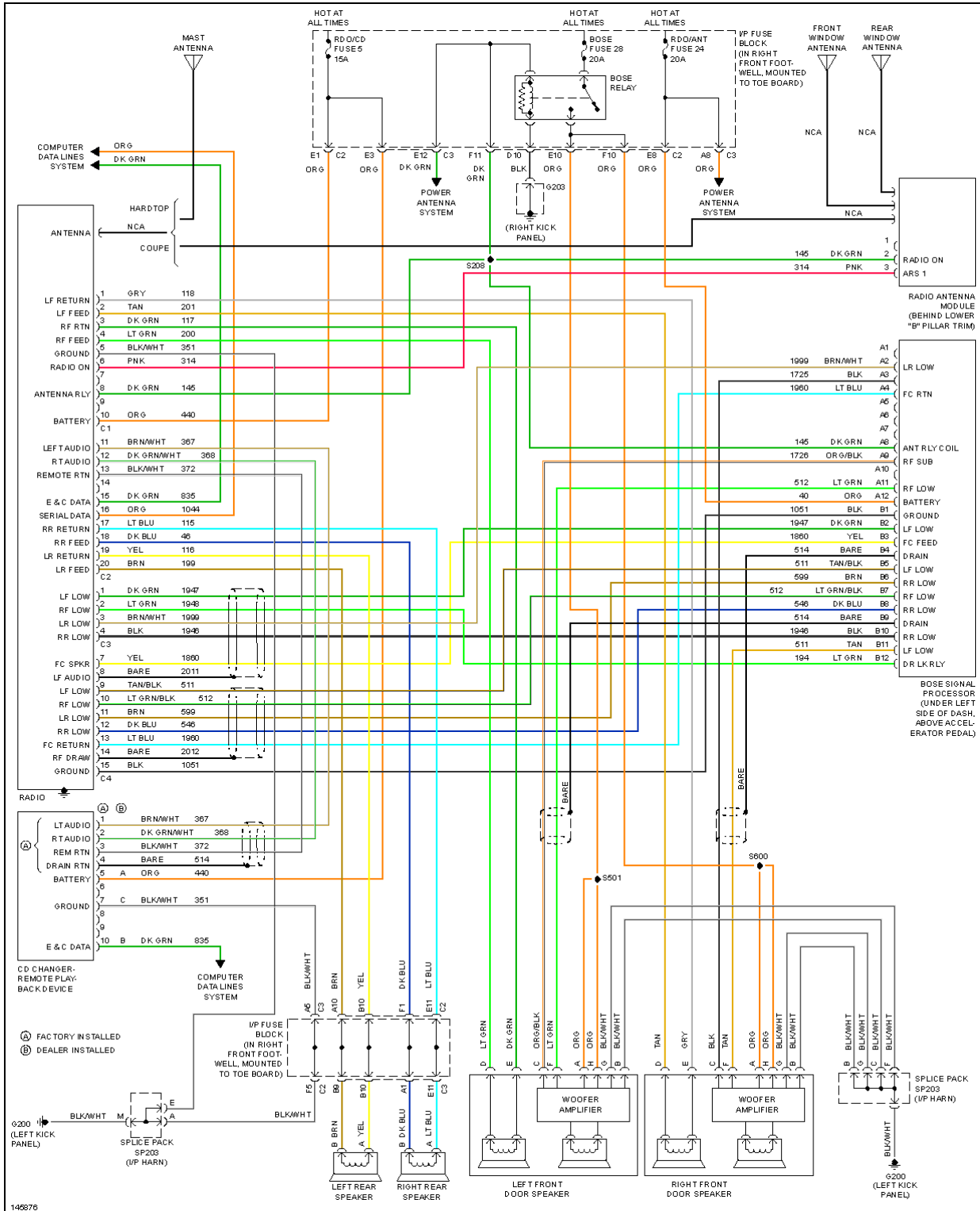

**Fig. 40: Power Window Circuit**

**RADIO**

# 2001 Chevrolet Corvette

## 2001 SYSTEM WIRING DIAGRAMS CHEVROLET Corvette

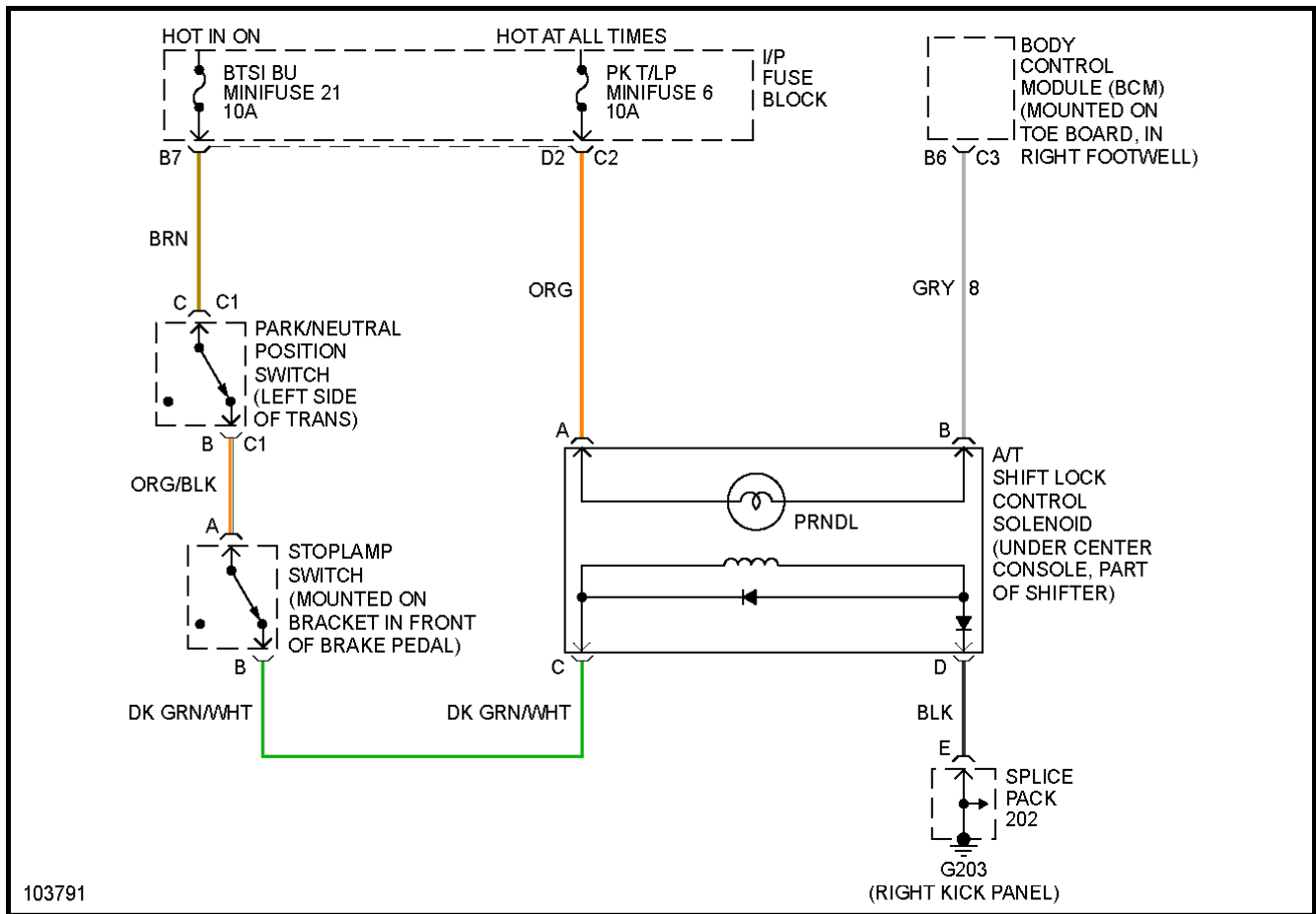

**Fig. 41: Radio Circuits**

**SHIFT INTERLOCKS**

# 2001 Chevrolet Corvette

## 2001 SYSTEM WIRING DIAGRAMS CHEVROLET Corvette

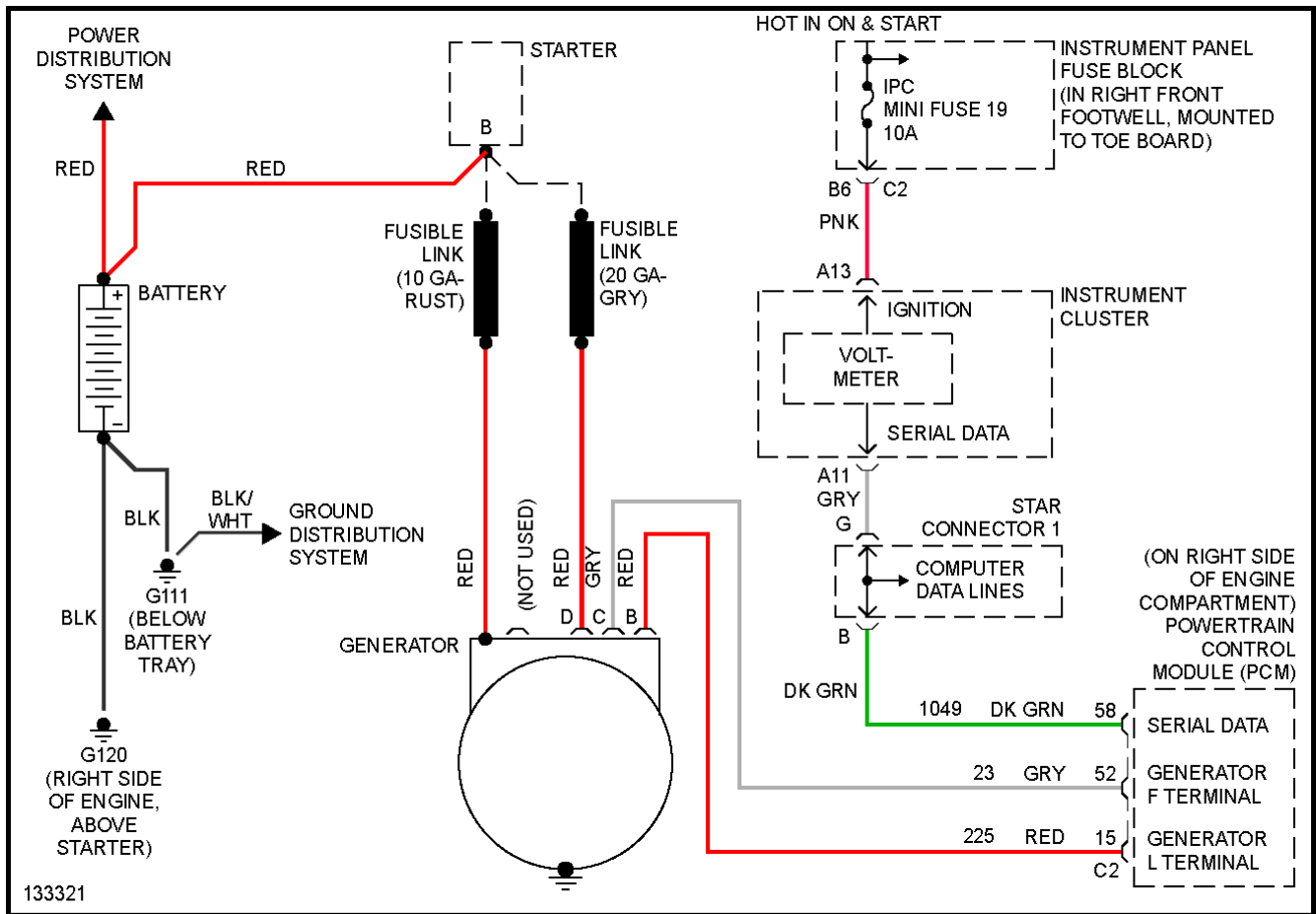

**Fig. 42: Shift Interlock Circuit**

**STARTING/CHARGING**

# 2001 Chevrolet Corvette

## 2001 SYSTEM WIRING DIAGRAMS CHEVROLET Corvette



**Fig. 43: Charging Circuit**

# 2001 Chevrolet Corvette

## 2001 SYSTEM WIRING DIAGRAMS CHEVROLET Corvette

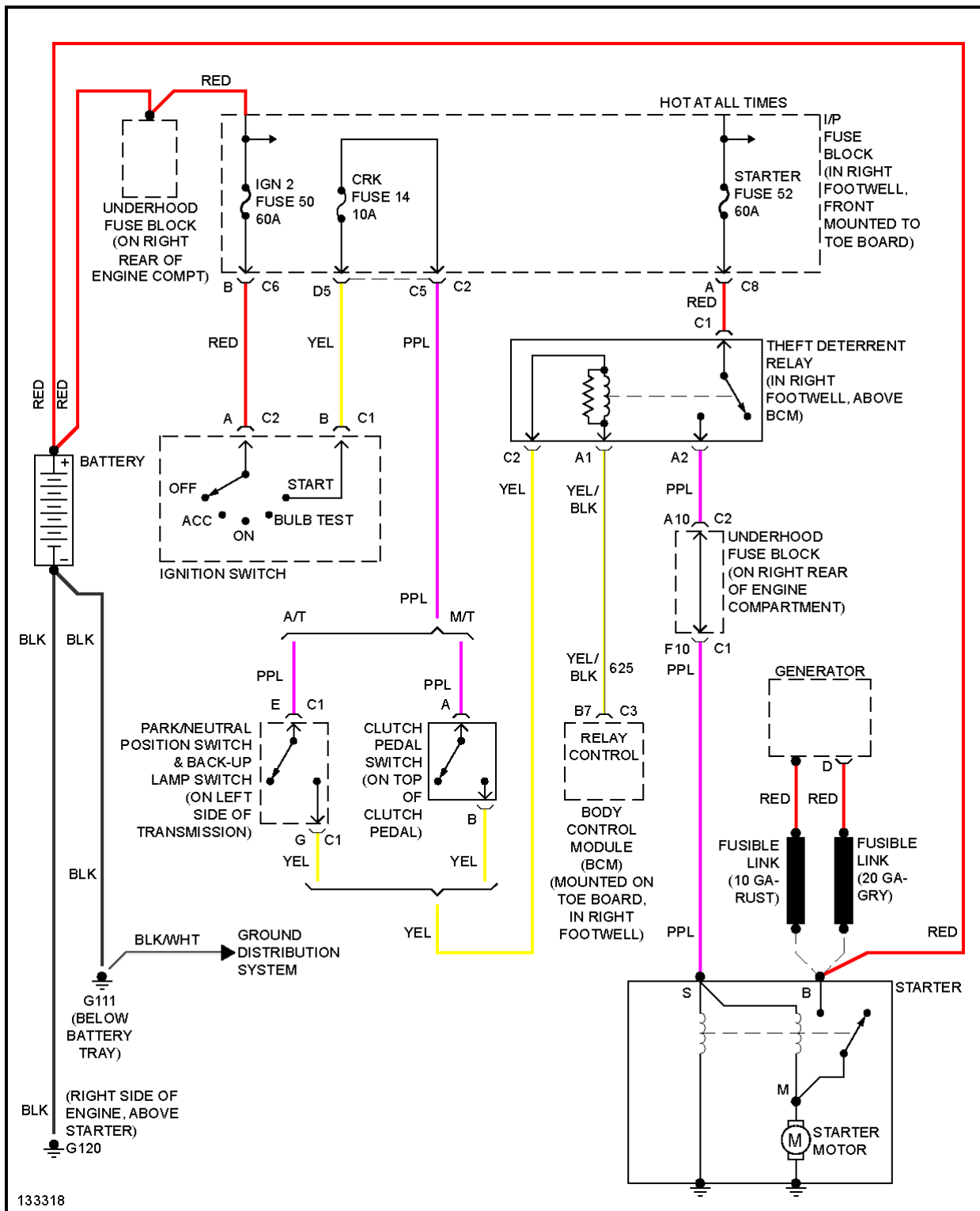

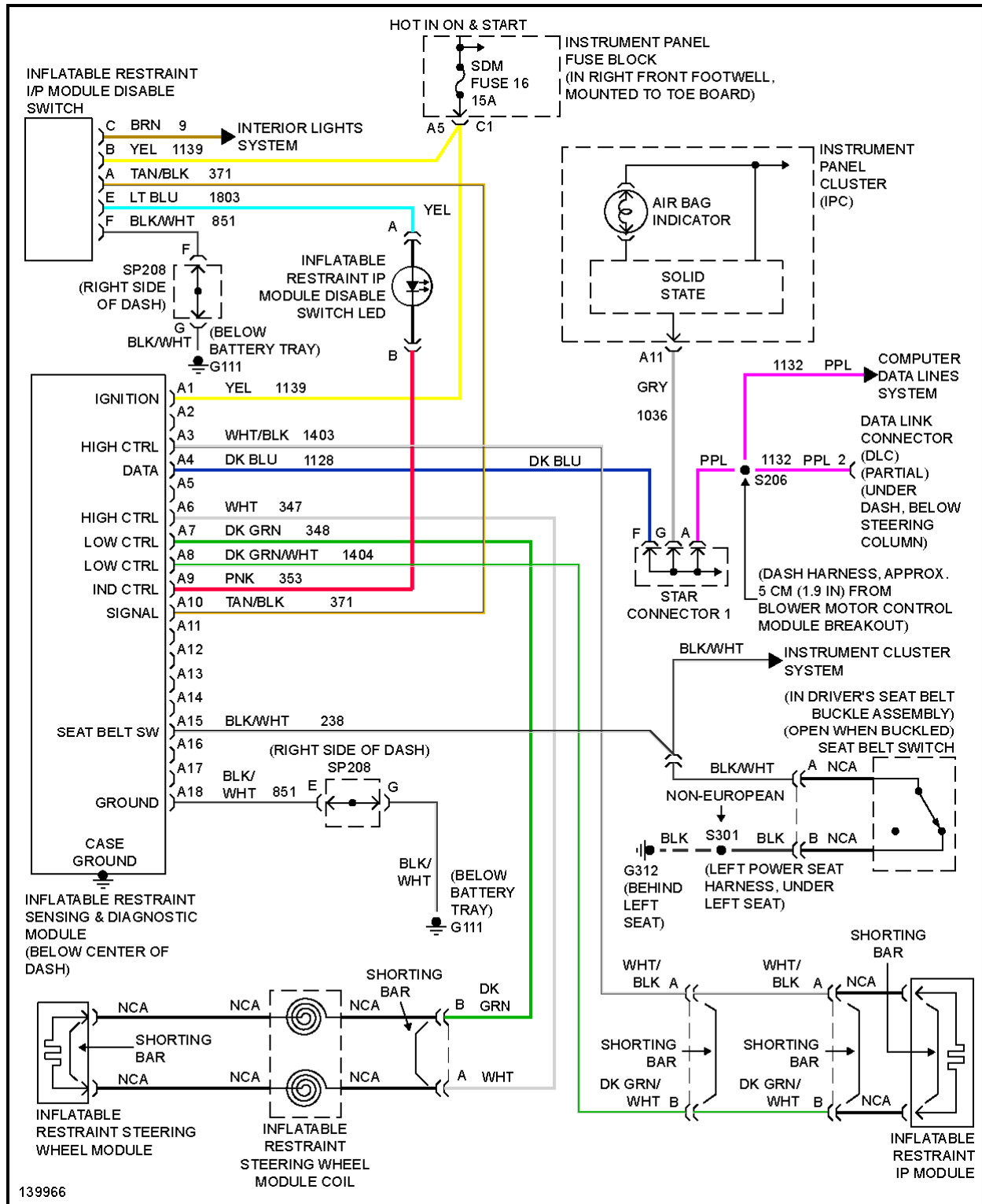

**Fig. 44: Starting Circuit**

**SUPPLEMENTAL RESTRAINTS**

# 2001 Chevrolet Corvette

## 2001 SYSTEM WIRING DIAGRAMS CHEVROLET Corvette



**Fig. 45: Supplemental Restraint Circuit**

**TRANSMISSION**

5.7L

# 2001 Chevrolet Corvette

## 2001 SYSTEM WIRING DIAGRAMS CHEVROLET Corvette

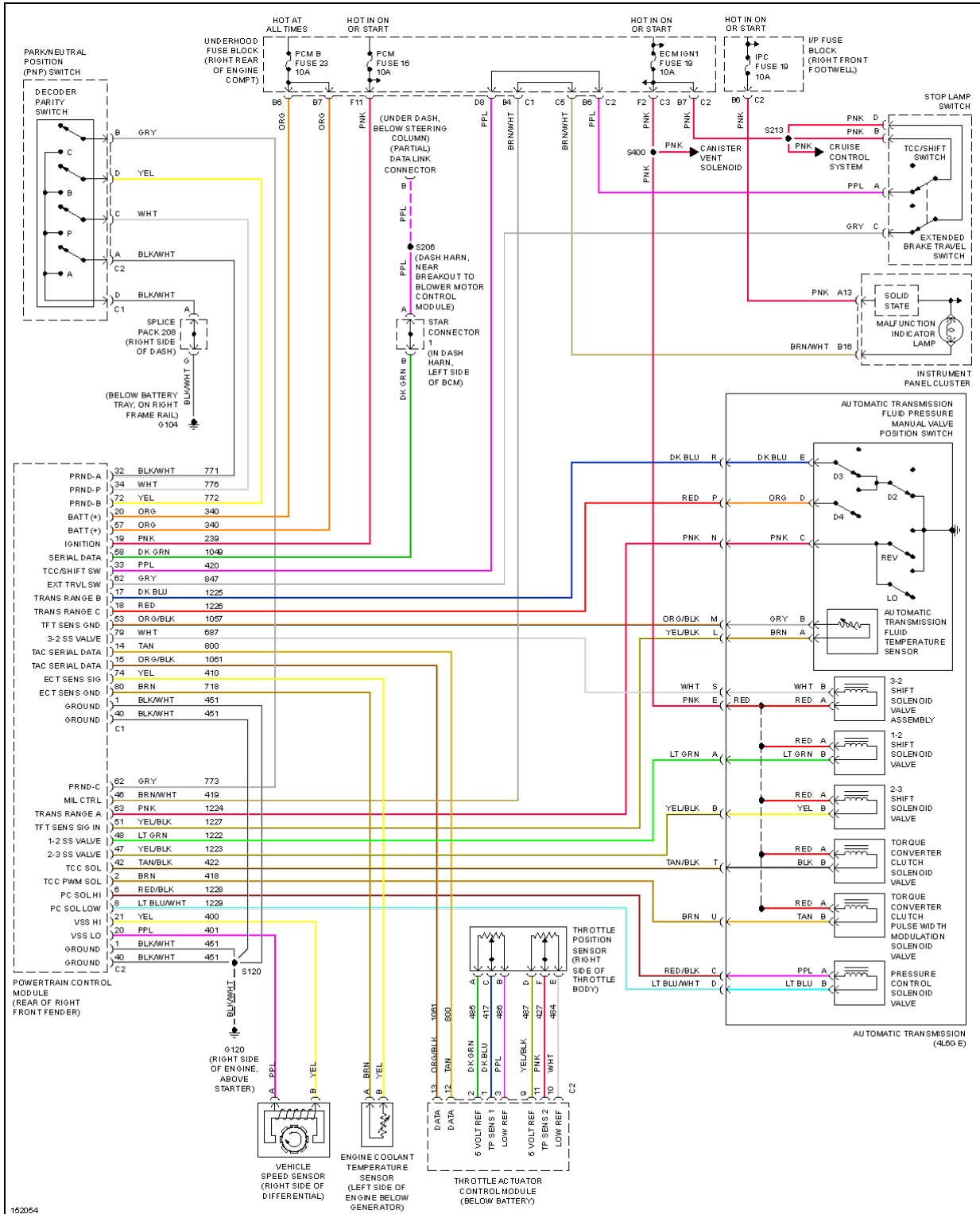

**2001 Chevrolet Corvette**

2001 SYSTEM WIRING DIAGRAMS CHEVROLET Corvette

**Fig. 46: 5.7L VIN G, A/T Circuit**

# 2001 Chevrolet Corvette

## 2001 SYSTEM WIRING DIAGRAMS CHEVROLET Corvette

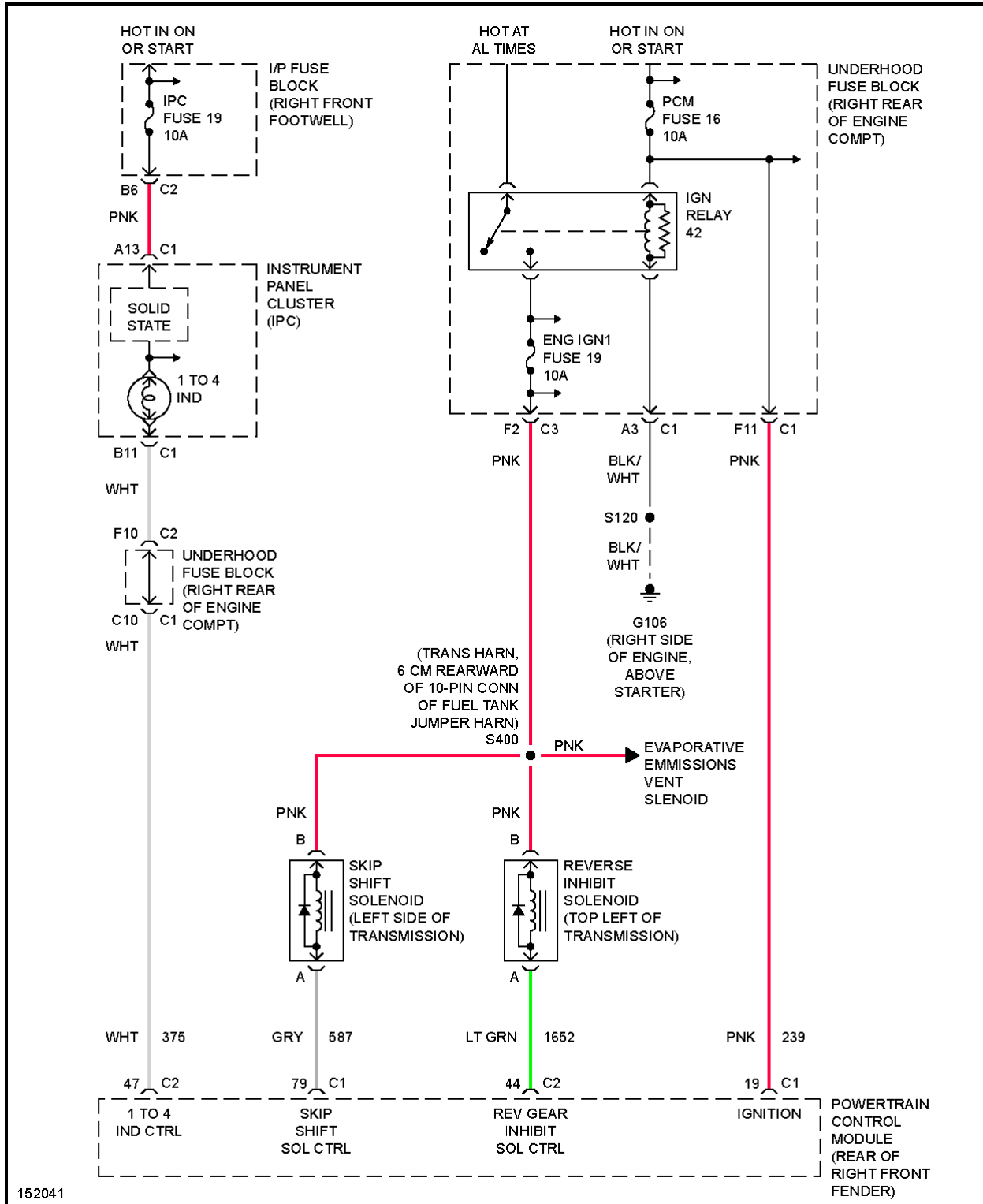
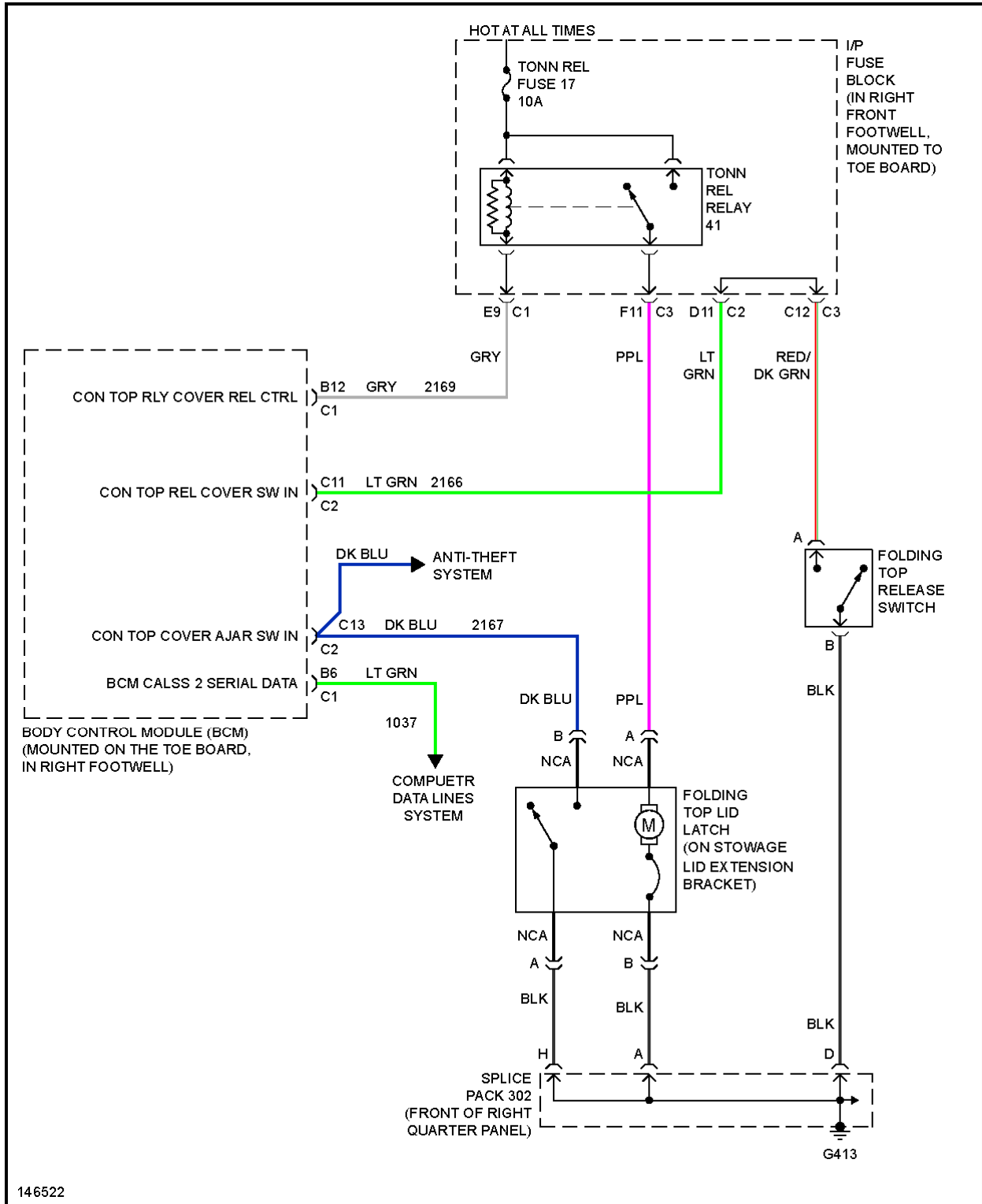

**Fig. 47: 5.7L VIN G, M/T Circuit**

**TRUNK, TAILGATE, FUEL DOOR**

# 2001 Chevrolet Corvette

## 2001 SYSTEM WIRING DIAGRAMS CHEVROLET Corvette

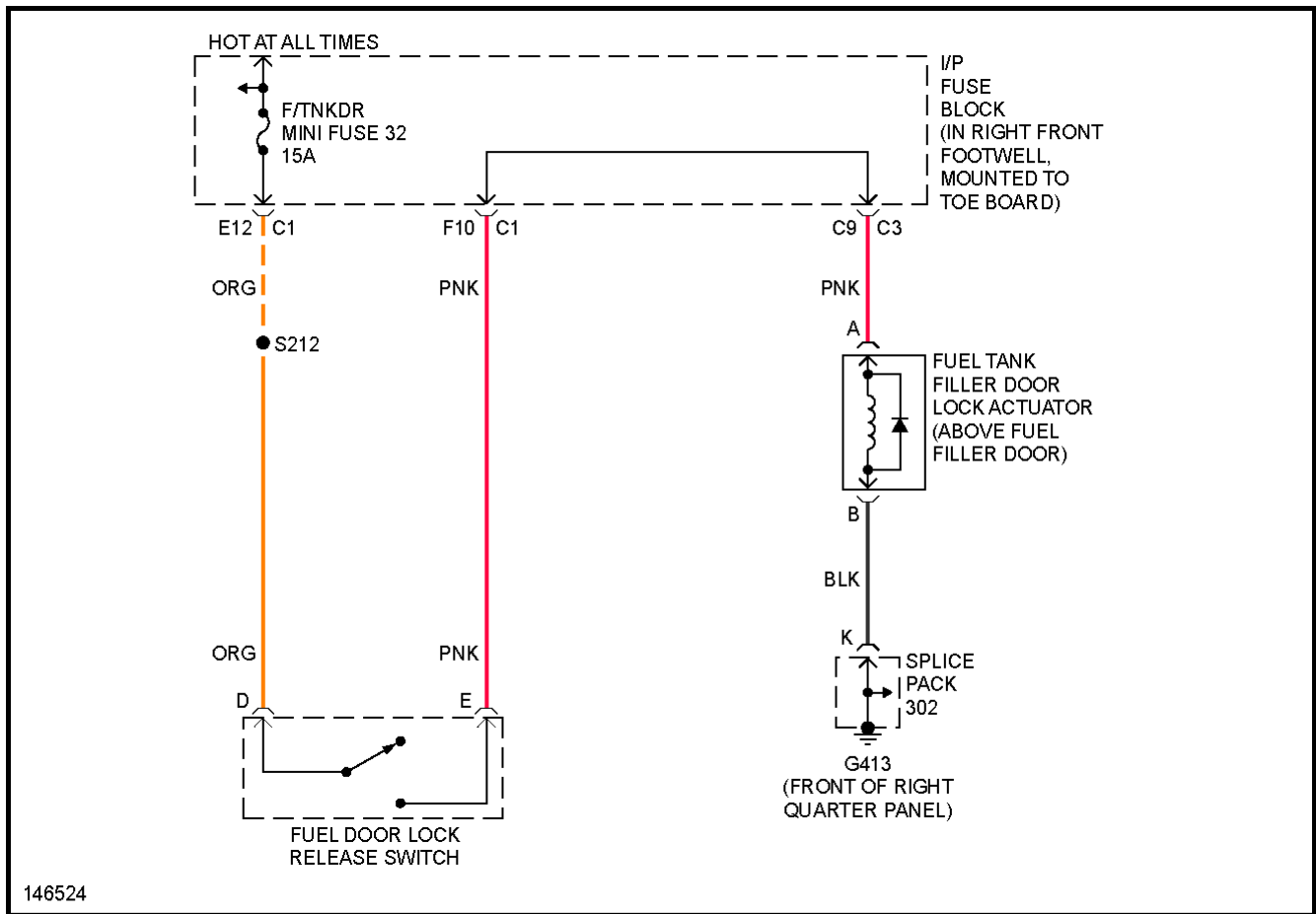



**Fig. 48: Folding Top Lid Release Circuit**

# 2001 Chevrolet Corvette

## 2001 SYSTEM WIRING DIAGRAMS CHEVROLET Corvette



**Fig. 49: Fuel Door Release Circuit**

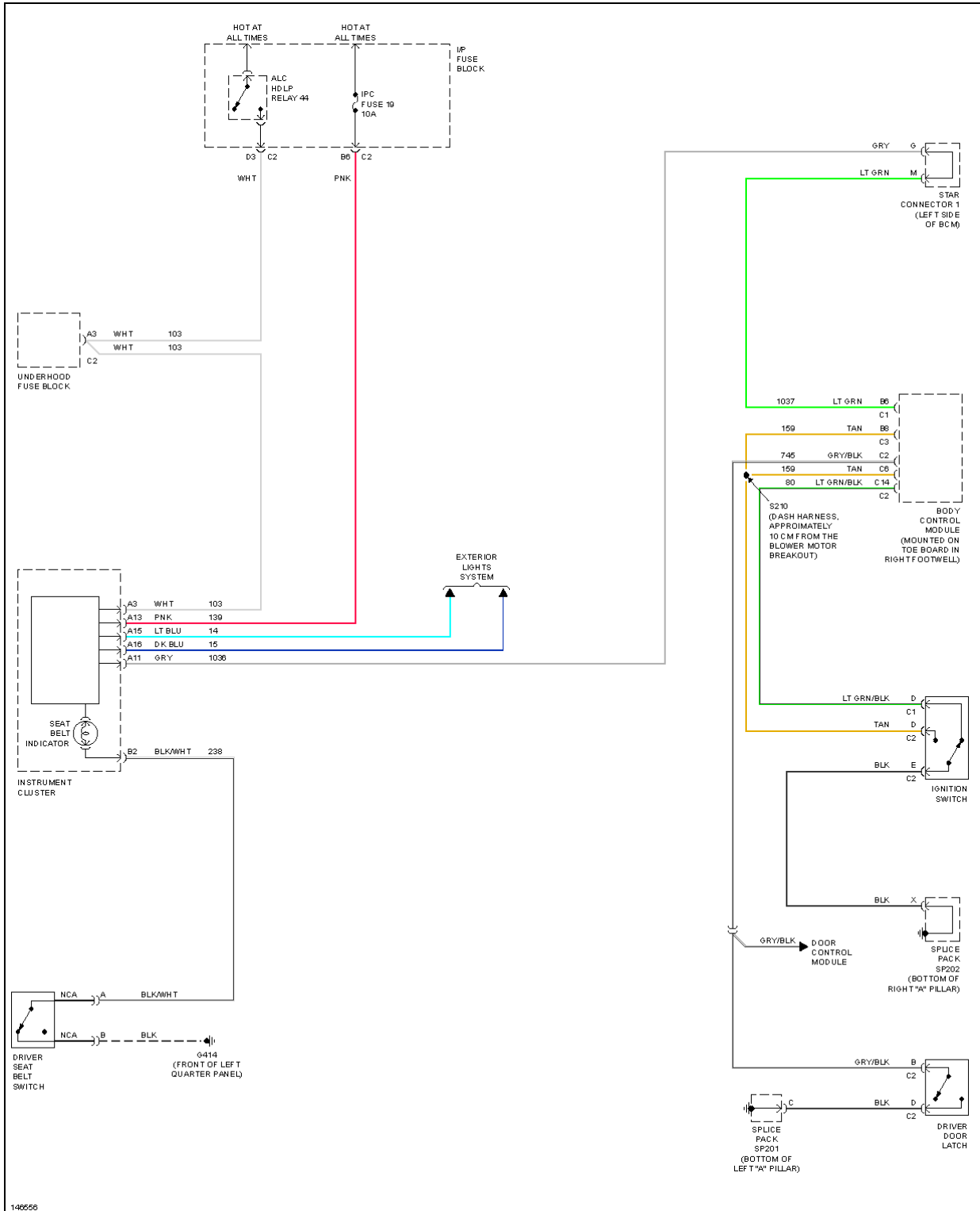

**Fig. 50: Hatch Release Circuit**

**WARNING SYSTEMS**

# 2001 Chevrolet Corvette

## 2001 SYSTEM WIRING DIAGRAMS CHEVROLET Corvette

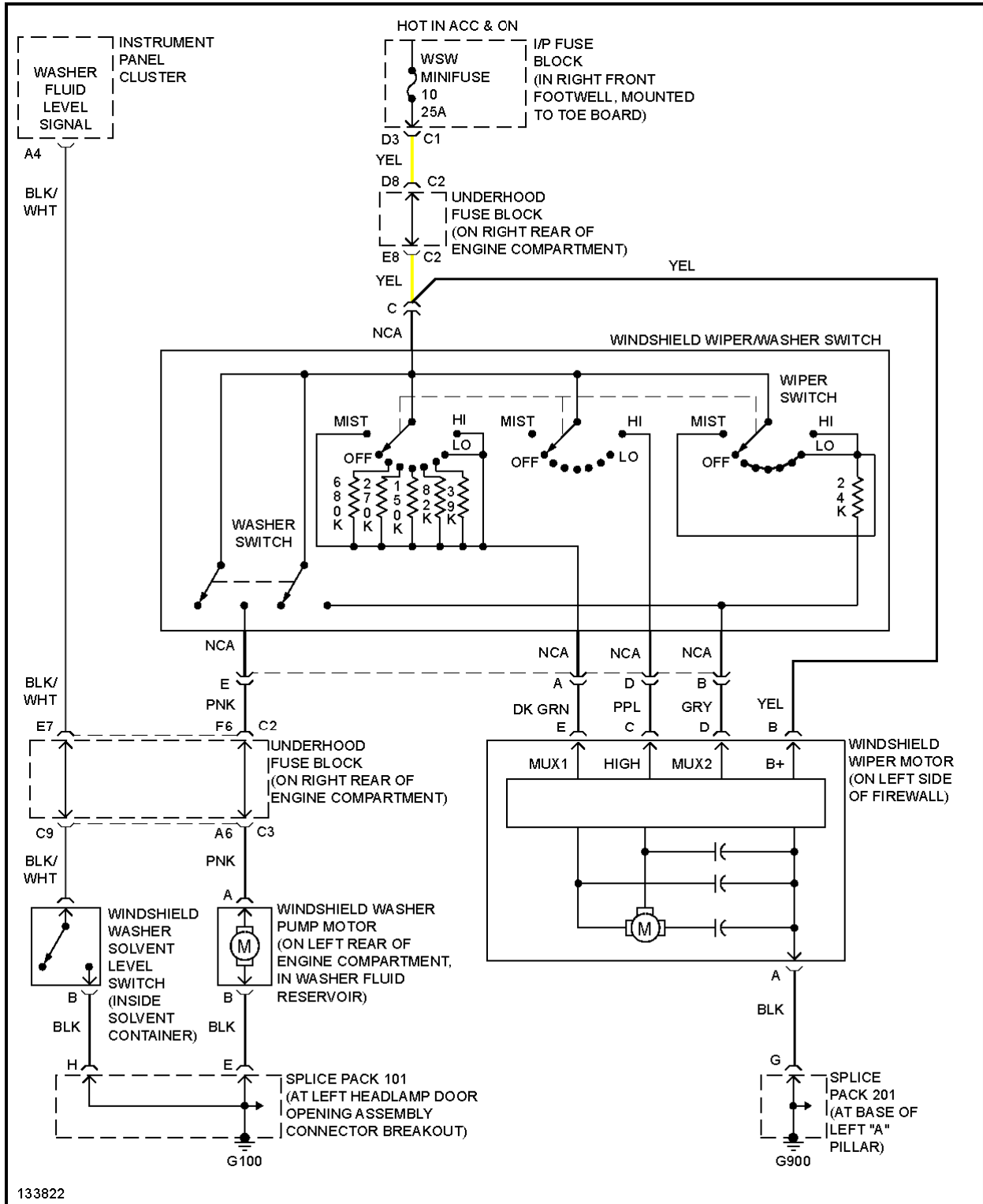

**Fig. 51: Warning System Circuits**

**WIPER/WASHER**

# 2001 Chevrolet Corvette

## 2001 SYSTEM WIRING DIAGRAMS CHEVROLET Corvette





**Fig. 52: Wiper/Washer Circuit**