

## 1998 Chevrolet Corvette

SEATS - POWER 1998 ACCESSORIES & EQUIPMENT General Motors Corp. - Power Seats

### SEATS - POWER

#### 1998 ACCESSORIES & EQUIPMENT General Motors Corp. - Power Seats

### DESCRIPTION & OPERATION

Power seats operate using toggle switches located on seat side. Seat adjusters are powered by a 12-volt, reversible motor with an internal circuit breaker. A 20-amp, plug-in circuit breaker, located in instrument panel electrical center, protects power seat wiring. Optional features include memory, power recline and power lumbar.

#### SIX-WAY POWER SEATS

Power seat uses 3 reversible motors that operate seat functions. Front and back parts of seat are operated by different motors, and can be raised and lowered independently. Third motor controls forward/backward movement.

#### MEMORY SEATS

**NOTE:** For information on memory seat systems diagnostic and repair procedures, see MEMORY SYSTEMS article.

Memory functions are controlled with buttons located in armrest of driver's door. Memory seat, outside mirror, climate control and stereo settings for up to 3 different drivers can be recorded into the seat control module through the memory panel buttons.

To program the seat control module, move seat to most comfortable position. Depress and hold the No. 1 memory button until the indicator light above the memory button glows steady. Continue to hold button down. When the position has been stored, the light will flash once. To record the second setting, repeat function and depress the No. 2 button. For the third setting, the No. 1 and 2 buttons will need to be depressed simultaneously.

To recall a position, depress the button the corresponds with the setting you want recalled. Indicator light will flash until programmed position is achieved. Memory recall will not work if the vehicle is moving, the key is out of the ignition switch or if a seat or memory switch is being used.

### COMPONENT LOCATIONS

#### COMPONENT LOCATIONS

Component	Location
Door Control Module (DCM)	Bottom Center Of Respective Door
Instrument Panel Electrical Center	(1) *
Seat Lower & Upper Motors	Under Respective Front Seat

## 1998 Chevrolet Corvette

SEATS - POWER 1998 ACCESSORIES & EQUIPMENT General Motors Corp. - Power Seats

Seat Control Module (SCM)	Under Driver's Seat
Seat Relay Center	Under Respective Front Seat
(1) Top of passenger's footwell, behind carpet. See <b>Fig. 1</b> .	

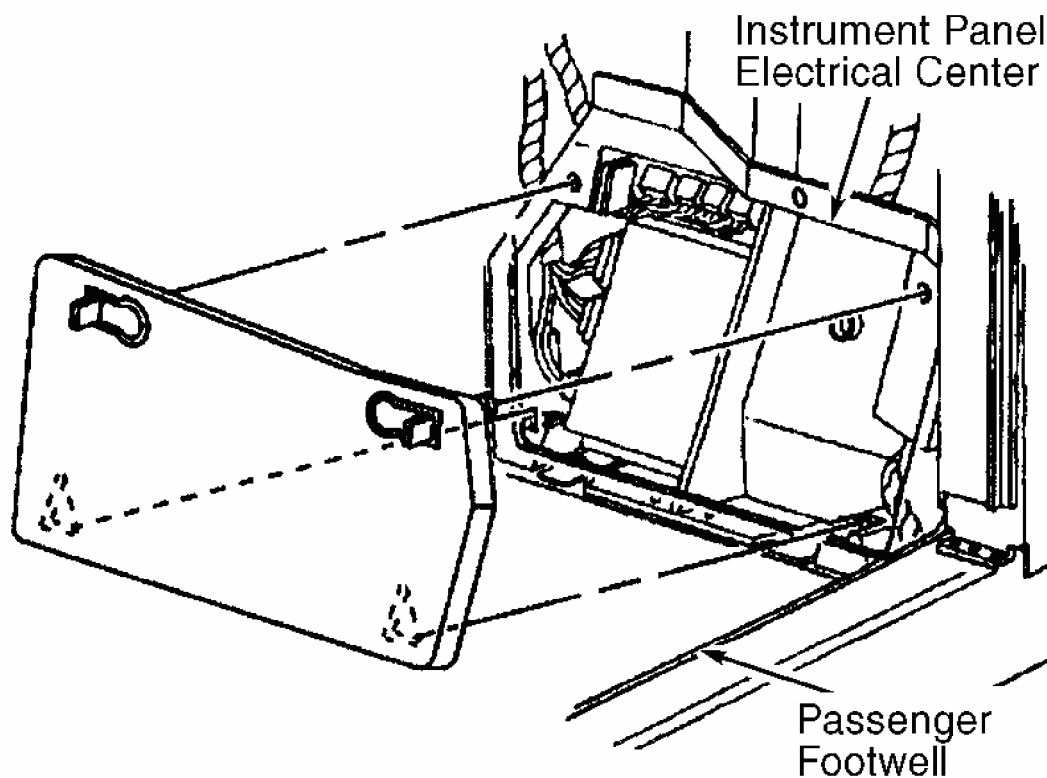

G98G12225

**Fig. 1: Locating Instrument Panel Electrical Center**  
Courtesy of GENERAL MOTORS CORP.

## TROUBLE SHOOTING

### PRELIMINARY CHECKS

1. If power accessory circuit breaker opens whenever power seat switch is operated, check circuits for a short to ground. Check fuses. Check for good, clean ground connections. Check for proper installation of aftermarket electronic equipment.
2. Check for broken or partially broken wire inside of insulation, which could cause system malfunction but prove good in a continuity/voltage check with system disconnected. These circuits may be intermittent or resistive when loaded. Check by monitoring for voltage drop with system under load.

## **SELF-DIAGNOSTICS**

### **RETRIEVING DIAGNOSTIC TROUBLE CODES (DTCS)**

#### **Using On-Board Diagnostics**

If any warning messages exist, depress the RESET button. Depress and hold the OPTIONS button and press the FUEL button 4 times within 5 seconds of depressing the OPTIONS button. The module number and module name will appear on Driver's Information Center (DIC) display. The module number for the Body Control Module (BCM) is No. 40. After module number is displayed, individual DTCs will be displayed.

To begin manual control of DTC viewing, depress the FUEL, TRIP, GAUGES, OPTIONS or RESET button. See **Fig. 2** . Depress the TRIP button to view previous module. Depress the OPTIONS button to view next module. Depress the FUEL button to view previous DTC in selected module. Depress the GAUGES button to view next DTC in selected module. After retrieving and recording current and history DTCs, proceed to appropriate DTC and follow diagnostic and repair procedures. Depress the E/M button to exit self-diagnostics.

#### **Using Scan Tool**

Diagnostic Trouble Codes (DTCs) can also be retrieved using scan tool. Connect scan tool to Data Link Connector (DLC) located under driver's side of instrument panel. Turn ignition switch to ON position. Select appropriate module on scan tool display to retrieve current and history DTCs. Record DTCs and proceed to appropriate DTC and follow diagnostic and repair procedures.

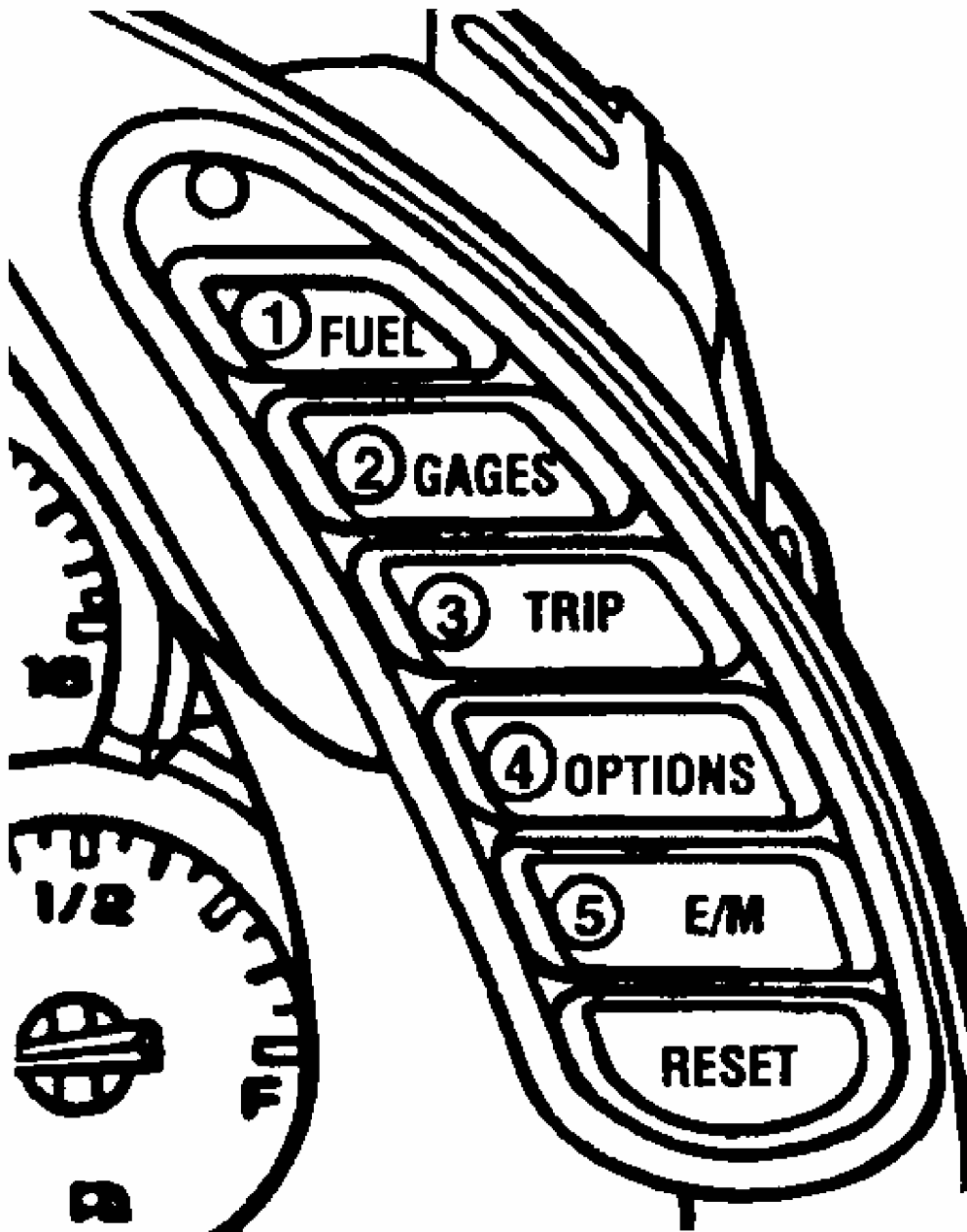

DIC CONTROL PANEL

G98J12228

## 1998 Chevrolet Corvette

SEATS - POWER 1998 ACCESSORIES & EQUIPMENT General Motors Corp. - Power Seats

### CLEARING DIAGNOSTIC TROUBLE CODES (DTCS)

Current DTCs will clear as soon as the fault is repaired. History DTCs will need to be manually cleared. One way to clear history codes is to disconnect the negative battery cable for a minimum of 10 seconds.

#### Using On-Board Diagnostics

Use manual control functions to select and view DTC. See **RETRIEVING** DTCs. Depress reset button for 2 seconds to clear the selected DTC from the selected module.

#### Using Scan Tool

Select CLEAR DTCs function on scan tool. Clear current and history DTCs. Operate vehicle and recheck for DTCs.

### DTC DEFINITIONS

#### POWER SEAT DIAGNOSTIC TROUBLE CODES (DTCs)

DTC	Application
B0851	Battery 1 Out Of Range
B0846	Battery 2 Out Of Range
B2002	Fore/Aft Seat Motor Open Or Shorted
B2007	Front Vertical Seat Motor Open Or Shorted
B2012	Rear Vertical Seat Motor Open Or Shorted
B2172	Seat Front Up Switch Shorted To Ground
B2177	Seat Front Down Switch Shorted To Ground
B2182	Seat Rear Up Switch Shorted To Ground
B2187	Seat Rear Down Switch Shorted To Ground
B2192	Seat Forward Switch Shorted To Ground
B2197	Seat Reverse Switch Shorted To Ground
B2605	Seat Front Vertical Position Sensor Failure
B2606	Seat Rear Vertical Position Sensor Failure
B2607	Seat Horizontal Position Sensor Failure

### TESTING - DIAGNOSTIC

**NOTE:** Following tests are for models equipped with memory seat. Information for testing other seat functions is not available from manufacturer at time of publication. See **WIRING DIAGRAMS** .

**DTC B0846: BATTERY 2 OUT OF RANGE**

## 1998 Chevrolet Corvette

SEATS - POWER 1998 ACCESSORIES & EQUIPMENT General Motors Corp. - Power Seats

1. Disconnect Seat Control Module (SCM) connector. Using DVOM, check voltage between SCM harness connector C3 terminal "A" (Orange wire) and ground. See **Fig. 3** . If reading is 10-14 volts, go to next step. If reading is not 10-14 volts, go to step 3).
2. Replace SCM. See **POWER SEAT ADJUSTER** under REMOVAL & INSTALLATION. Recheck system operation.
3. Disconnect left seat harness connector C301, located under left seat. Check voltage between connector C301 terminal "C" (Orange wire) and ground. If reading is 10-14 volts, go to next step. If reading is not 10-14 volts, go to step 5).
4. Repair open in Orange wire between connector C301 and SCM connector C3. Recheck system operation.
5. Disconnect instrument panel electrical center connector C2. Using DVOM, check voltage between instrument panel electrical center connector C2 (component-side) terminal F8 (Orange wire) and ground. If reading is 10-14 volts, go to next step. If reading is not 10-14 volts, go to step 7).
6. Repair open in Orange wire between connector C301 and instrument panel electrical center connector C2. Recheck system operation.
7. Replace instrument panel electrical center. Recheck system operation.

### DTC B0851: BATTERY 1 OUT OF RANGE

1. Disconnect Seat Control Module (SCM) connector. Using DVOM, check voltage between SCM harness connector C1 terminal No. 3 (Orange wire) and ground. If reading is 10-14 volts, go to next step. If reading is not 10-14 volts, go to step 3).
2. Replace SCM. See **POWER SEAT ADJUSTER** under REMOVAL & INSTALLATION. Recheck system operation.
3. Disconnect left seat harness connector C301, located under left seat. Check voltage between connector C301 terminal "E" (Orange wire) and ground. If reading is 10-14 volts, go to next step. If reading is not 10-14 volts, go to step 5).
4. Repair open in Orange wire between connector C301 and SCM connector C1. Recheck system operation.
5. Disconnect instrument panel electrical center connector C1. Using DVOM, check voltage between instrument panel electrical center connector C1 (component-side) terminal C12 (Orange wire) and ground. If reading is 10-14 volts, go to next step. If reading is not 10-14 volts, go to step 7).
6. Repair open in Orange wire between connector C301 and instrument panel electrical center connector C1. Recheck system operation.
7. Replace instrument panel electrical center. Recheck system operation.

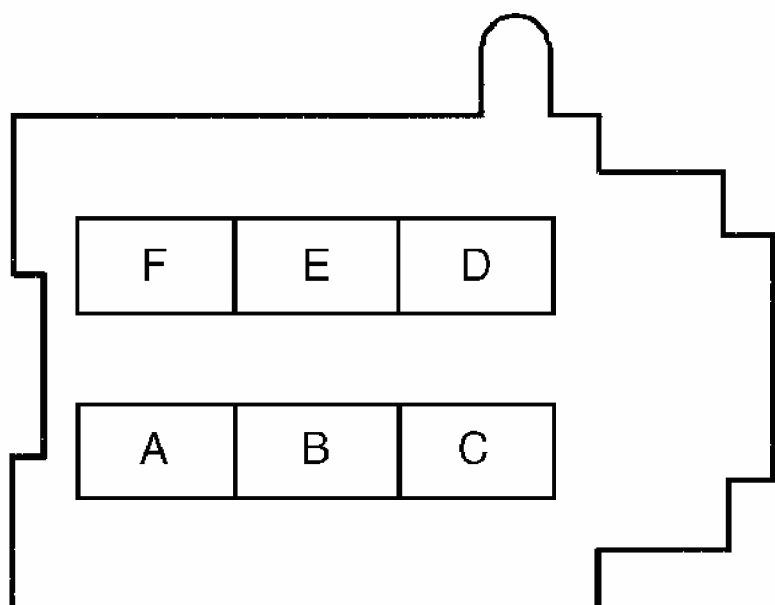

C2

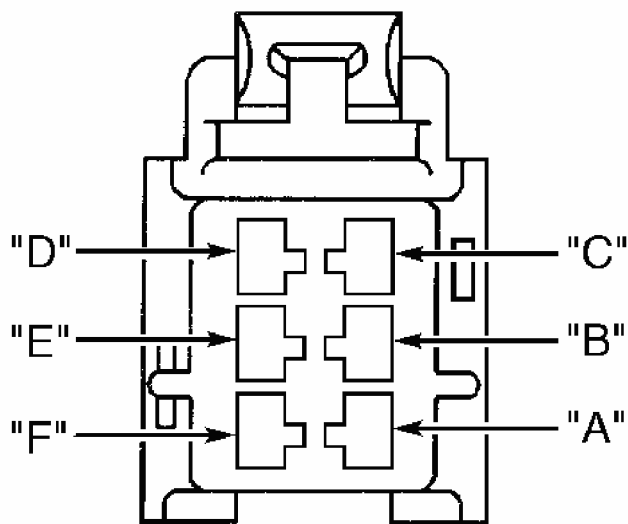

C3

G98D12222

**Fig. 3: Identifying Seat Control Module Connectors Terminals**  
Courtesy of GENERAL MOTORS CORP.

**DTC B2002: FORE/AFT SEAT MOTOR OPEN OR SHORTED**

1. Disconnect left seat lower motor connector C1. Using DVOM, check voltage between left seat lower motor harness connector C1 terminals "A" (Light Green wire) and

## 1998 Chevrolet Corvette

SEATS - POWER 1998 ACCESSORIES & EQUIPMENT General Motors Corp. - Power Seats

"B" (Light Green wire). See **Fig. 4** . Move left seat switch forward, then reverse. If reading is 10-14 volts at both positions, go to next step. If reading is not 10-14 volts at both positions, go to step 3).

2. Replace left seat lower motor. See **SEAT ADJUSTER MOTORS** under REMOVAL & INSTALLATION. Recheck system operation.
3. Check for open in appropriate Light Green wire(s) between left seat lower motor connector C1 and SCM connector C2 or C3. See **Fig. 3** . Repair as necessary. If circuit is okay, replace SCM. See **POWER SEAT ADJUSTER** under REMOVAL & INSTALLATION. Recheck system operation.

### DTC B2007: FRONT VERTICAL SEAT MOTOR OPEN OR SHORTED

1. Disconnect left seat lower motor connector C1. Using DVOM, check voltage between left seat lower motor harness connector C1 terminals "C" (Dark Green wire) and "D" (Dark Blue wire). See **Fig. 4** . Move left seat front vertical switch up, then down. If reading is 10-14 volts at both positions, go to next step. If reading is not 10-14 volts at both positions, go to step 3).
2. Replace left seat lower motor. See **SEAT ADJUSTER MOTORS** under REMOVAL & INSTALLATION. Recheck system operation.
3. Check for open in Dark Green wire or Dark Blue wire between left seat lower motor connector C1 and SCM connector C2 or C3. See **Fig. 3** . Repair as necessary. If circuit is okay, replace SCM. See **POWER SEAT ADJUSTER** under REMOVAL & INSTALLATION. Recheck system operation.



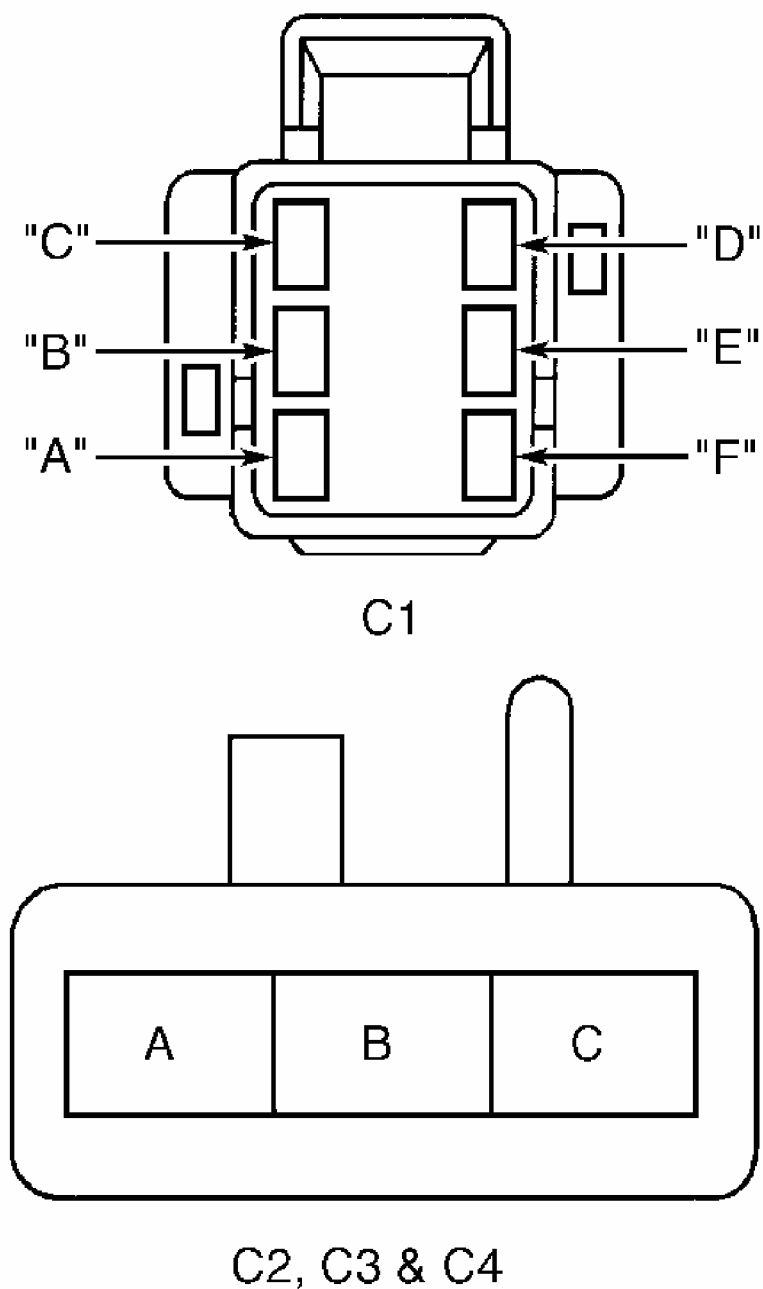

G98E12223

**Fig. 4: Identifying Left Seat Lower Motor Connectors Terminals**  
Courtesy of GENERAL MOTORS CORP.

**DTC B2012: REAR VERTICAL SEAT MOTOR OPEN OR SHORTED**

1. Disconnect left seat lower motor connector C1. Using DVOM, check voltage between left seat lower motor harness connector C1 terminals "E" (Yellow wire) and "F" (Light

## 1998 Chevrolet Corvette

SEATS - POWER 1998 ACCESSORIES & EQUIPMENT General Motors Corp. - Power Seats

Blue wire). See **Fig. 4** . Move left seat rear vertical switch up, then down. If reading is 10-14 volts at both positions, go to next step. If reading is not 10-14 volts at both positions, go to step 3).

2. Replace left seat lower motor. See **SEAT ADJUSTER MOTORS** under REMOVAL & INSTALLATION. Recheck system operation.
3. Check for open in Yellow wire or Light Blue wire between left seat lower motor connector C1 and SCM connector C2 or C3. See **Fig. 3** . Repair as necessary. If circuit is okay, replace SCM. See **POWER SEAT ADJUSTER** under REMOVAL & INSTALLATION. Recheck system operation.

### DTC B2172: SEAT FRONT UP SWITCH SHORTED TO GROUND

1. If there is any binding or obstruction in seat mechanisms, repair as necessary. If there is no binding or obstruction in seat mechanisms, go to next step.
2. Disconnect Seat Control Module (SCM) connector. While pressing seat front up switch, use DVOM to check resistance between SCM harness connector C1 terminals No. 17 (Dark Blue wire) and No. 8 (Gray/Black wire). If resistance is less than 5 ohms, go to next step. If resistance is not less than 5 ohms, go to step 4).
3. Replace SCM. See **POWER SEAT ADJUSTER** under REMOVAL & INSTALLATION. Recheck system operation.
4. Disconnect left seat switch. While pressing seat front up switch, use DVOM to check resistance between left seat switch (component-side) terminals No. 1 (Dark Blue wire) and No. 7 (Gray/Black wire). See **Fig. 5** . If resistance is less than 5 ohms, go to next step. If resistance is not less than 5 ohms, go to step 6).
5. Repair open in Dark Blue wire or Gray/Black wire between left seat switch and SCM connector C1. Recheck system operation.
6. Replace left seat switch. See **POWER SEAT SWITCH** under REMOVAL & INSTALLATION. Recheck system operation.

### DTC B2177: SEAT FRONT DOWN SWITCH SHORTED TO GROUND

1. If there is any binding or obstruction in seat mechanisms, repair as necessary. If there is no binding or obstruction in seat mechanisms, go to next step.
2. Disconnect Seat Control Module (SCM) connector. While pressing seat front down switch, use DVOM to check resistance between SCM harness connector C1 terminals No. 16 (Dark Green wire) and No. 8 (Gray/Black wire). If resistance is less than 5 ohms, go to next step. If resistance is not less than 5 ohms, go to step 4).
3. Replace SCM. See **POWER SEAT ADJUSTER** under REMOVAL & INSTALLATION. Recheck system operation.
4. Disconnect left seat switch. While pressing seat front down switch, use DVOM to check resistance between left seat switch (component-side) terminals No. 26 (Dark Green wire) and No. 7 (Gray/Black wire). See **Fig. 5** . If resistance is less than 5 ohms,

- go to next step. If resistance is not less than 5 ohms, go to step 6).
5. Repair open in Dark Green wire or Gray/Black wire between left seat switch and SCM connector C1. Recheck system operation.
  6. Replace left seat switch. See **POWER SEAT SWITCH** under REMOVAL & INSTALLATION. Recheck system operation.

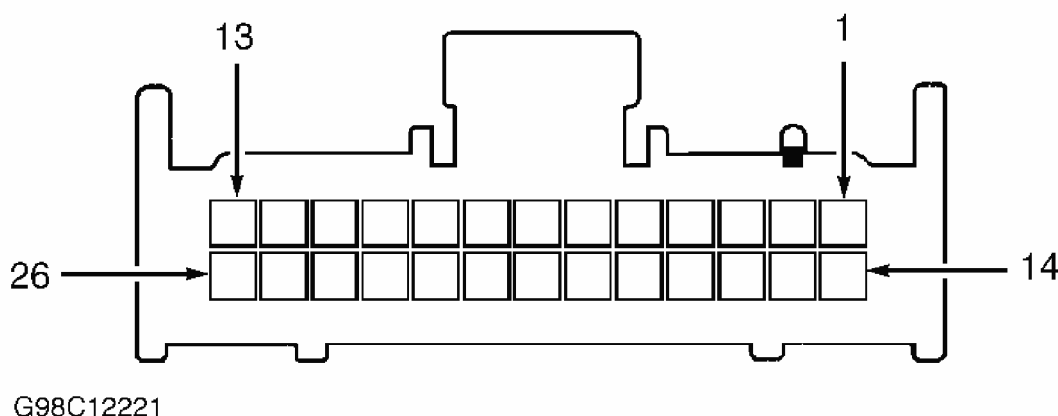

**Fig. 5: Identifying Driver Seat Switch Connector Terminals**  
 Courtesy of GENERAL MOTORS CORP.

**DTC B2182: SEAT REAR UP SWITCH SHORTED TO GROUND**

1. If there is any binding or obstruction in seat mechanisms, repair as necessary. If there is no binding or obstruction in seat mechanisms, go to next step.
2. Disconnect Seat Control Module (SCM) connector. While pressing seat rear up switch, use DVOM to check resistance between SCM harness connector C1 terminals No. 1 (Yellow wire) and No. 8 (Gray/Black wire). If resistance is less than 5 ohms, go to next step. If resistance is not less than 5 ohms, go to step 4).
3. Replace SCM. See **POWER SEAT ADJUSTER** under REMOVAL & INSTALLATION. Recheck system operation.
4. Disconnect left seat switch. While pressing seat rear up switch, use DVOM to check resistance between left seat switch (component-side) terminals No. 3 (Yellow wire) and No. 7 (Gray/Black wire). See **Fig. 5** . If resistance is less than 5 ohms, go to next step. If resistance is not less than 5 ohms, go to step 6).
5. Repair open in Yellow wire or Gray/Black wire between left seat switch and SCM connector C1. Recheck system operation.
6. Replace left seat switch. See **POWER SEAT SWITCH** under REMOVAL & INSTALLATION. Recheck system operation.

**DTC B2187: SEAT REAR DOWN SWITCH SHORTED TO GROUND**

## 1998 Chevrolet Corvette

SEATS - POWER 1998 ACCESSORIES & EQUIPMENT General Motors Corp. - Power Seats

1. If there is any binding or obstruction in seat mechanisms, repair as necessary. If there is no binding or obstruction in seat mechanisms, go to next step.
2. Disconnect Seat Control Module (SCM) connector. While pressing seat rear down switch, use DVOM to check resistance between SCM harness connector C1 terminals No. 12 (Light Blue wire) and No. 8 (Gray/Black wire). If resistance is less than 5 ohms, go to next step. If resistance is not less than 5 ohms, go to step 4).
3. Replace SCM. See **POWER SEAT ADJUSTER** under REMOVAL & INSTALLATION. Recheck system operation.
4. Disconnect left seat switch. While pressing seat rear down switch, use DVOM to check resistance between left seat switch (component-side) terminals No. 24 (Light Blue wire) and No. 7 (Gray/Black wire). See **Fig. 5** . If resistance is less than 5 ohms, go to next step. If resistance is not less than 5 ohms, go to step 6).
5. Repair open in Light Blue wire or Gray/Black wire between left seat switch and SCM connector C1. Recheck system operation.
6. Replace left seat switch. See **POWER SEAT SWITCH** under REMOVAL & INSTALLATION. Recheck system operation.

### DTC B2192: SEAT FORWARD SWITCH SHORTED TO GROUND

1. If there is any binding or obstruction in seat mechanisms, repair as necessary. If there is no binding or obstruction in seat mechanisms, go to next step.
2. Disconnect Seat Control Module (SCM) connector. While pressing seat forward switch, use DVOM to check resistance between SCM harness connector C1 terminals No. 2 (Gray wire) and No. 8 (Gray/Black wire). If resistance is less than 5 ohms, go to next step. If resistance is not less than 5 ohms, go to step 4).
3. Replace SCM. See **POWER SEAT ADJUSTER** under REMOVAL & INSTALLATION. Recheck system operation.
4. Disconnect left seat switch. While pressing seat forward switch, use DVOM to check resistance between left seat switch (component-side) terminals No. 14 (Gray wire) and No. 7 (Gray/Black wire). See **Fig. 5** . If resistance is less than 5 ohms, go to next step. If resistance is not less than 5 ohms, go to step 6).
5. Repair open in Gray wire or Gray/Black wire between left seat switch and SCM connector C1. Recheck system operation.
6. Replace left seat switch. See **POWER SEAT SWITCH** under REMOVAL & INSTALLATION. Recheck system operation.

### DTC B2197: SEAT REVERSE SWITCH SHORTED TO GROUND

1. If there is any binding or obstruction in seat mechanisms, repair as necessary. If there is no binding or obstruction in seat mechanisms, go to next step.
2. Disconnect Seat Control Module (SCM) connector. While pressing seat reverse switch, use DVOM to check resistance between SCM harness connector C1 terminals No. 15

(Brown wire) and No. 8 (Gray/Black wire). If resistance is less than 5 ohms, go to next step. If resistance is not less than 5 ohms, go to step 4).

3. Replace SCM. See **POWER SEAT ADJUSTER** under REMOVAL & INSTALLATION. Recheck system operation.
4. Disconnect left seat switch. While pressing seat reverse switch, use DVOM to check resistance between left seat switch (component-side) terminals No. 13 (Brown wire) and No. 7 (Gray/Black wire). See **Fig. 5** . If resistance is less than 5 ohms, go to next step. If resistance is not less than 5 ohms, go to step 6).
5. Repair open in Brown wire or Gray/Black wire between left seat switch and SCM connector C1. Recheck system operation.
6. Replace left seat switch. See **POWER SEAT SWITCH** under REMOVAL & INSTALLATION. Recheck system operation.

#### DTC B2605: SEAT FRONT VERTICAL POSITION SENSOR FAILURE

1. If DTC B2606 or B2607 is also set, go to next step. If DTC B2606 or B2607 is not set, go to step 6).
2. Disconnect left seat lower motor connector C2. Using DVOM, check voltage between left seat motor harness connector C2 terminal "A" (Purple wire) and ground. See **Fig. 4** . If reading is 4.5-5.5 volts, go to next step. If reading is not 4.5-5.5 volts, go to step 5).
3. Check voltage between left seat lower motor harness connector C2 terminals "A" (Purple wire) and "C" (Black wire). If reading is 4.5-5.5 volts, go to next step. If reading is not 4.5-5.5 volts, go to step 9).
4. Replace left seat lower motor. See **SEAT ADJUSTER MOTORS** under REMOVAL & INSTALLATION. Recheck system operation.
5. Check for open or short to ground in Purple wire between left seat lower motor connector C2 and SCM connector C1. Repair as necessary. If circuit is okay, replace SCM. See **POWER SEAT ADJUSTER** under REMOVAL & INSTALLATION. Recheck system operation.
6. Disconnect left seat lower motor connector C3. Using DVOM, check voltage between left seat motor harness connector C3 terminal "B" (Brown/White wire) and ground. See **Fig. 4** . If reading is 3.5-5.5 volts, go to next step. If reading is not 3.5-5.5 volts, go to step 8).
7. Replace left seat lower motor. See **SEAT ADJUSTER MOTORS** under REMOVAL & INSTALLATION. Recheck system operation.
8. Check for open, short to ground or short to voltage in Brown/White wire between left seat lower motor connector C3 and SCM connector C1. See **Fig. 3** . Repair as necessary. If circuit is okay, replace SCM. See **POWER SEAT ADJUSTER** under REMOVAL & INSTALLATION. Recheck system operation.
9. Check for open or short to voltage in Black wire between left seat lower motor

connector C2 and SCM connector C1. Repair as necessary. If circuit is okay, replace SCM. See **POWER SEAT ADJUSTER** under REMOVAL & INSTALLATION. Recheck system operation.

**DTC B2606: SEAT REAR VERTICAL POSITION SENSOR FAILURE**

1. If DTC B2605 or B2607 is also set, go to next step. If DTC B2605 or B2607 is not set, go to step 6).
2. Disconnect left seat lower motor connector C2. Using DVOM, check voltage between left seat motor harness connector C2 terminal "A" (Purple wire) and ground. See **Fig. 4** . If reading is 4.5-5.5 volts, go to next step. If reading is not 4.5-5.5 volts, go to step 5).
3. Check voltage between left seat lower motor harness connector C2 terminals "A" (Purple wire) and "C" (Black wire). If reading is 4.5-5.5 volts, go to next step. If reading is not 4.5-5.5 volts, go to step 9).
4. Replace left seat lower motor. See **SEAT ADJUSTER MOTORS** under REMOVAL & INSTALLATION. Recheck system operation.
5. Check for open or short to ground in Purple wire between left seat lower motor connector C2 and SCM connector C1. Repair as necessary. If circuit is okay, replace SCM. See **POWER SEAT ADJUSTER** under REMOVAL & INSTALLATION. Recheck system operation.
6. Disconnect left seat lower motor connector C4. Using DVOM, check voltage between left seat motor harness connector C4 terminal "B" (Tan wire) and ground. See **Fig. 4** . If reading is 3.5-5.5 volts, go to next step. If reading is not 3.5-5.5 volts, go to step 8).
7. Replace left seat lower motor. See **SEAT ADJUSTER MOTORS** under REMOVAL & INSTALLATION. Recheck system operation.
8. Check for open, short to ground or short to voltage in Tan wire between left seat lower motor connector C4 and SCM connector C1. Repair as necessary. If circuit is okay, replace SCM. See **POWER SEAT ADJUSTER** under REMOVAL & INSTALLATION. Recheck system operation.
9. Check for open or short to voltage in Black wire between left seat lower motor connector C2 and SCM connector C1. Repair as necessary. If circuit is okay, replace SCM. See **POWER SEAT ADJUSTER** under REMOVAL & INSTALLATION. Recheck system operation.

**DTC B2607: SEAT REAR HORIZONTAL POSITION SENSOR FAILURE**

1. If DTC B2605 or B2606 is also set, go to next step. If DTC B2605 or B2606 is not set, go to step 6).
2. Disconnect left seat lower motor connector C2. Using DVOM, check voltage between left seat motor harness connector C2 terminal "A" (Purple wire) and ground. See **Fig. 4** . If reading is 4.5-5.5 volts, go to next step. If reading is not 4.5-5.5 volts, go to step 5).

3. Check voltage between left seat lower motor harness connector C2 terminals "A" (Purple wire) and "C" (Black wire). If reading is 4.5-5.5 volts, go to next step. If reading is not 4.5-5.5 volts, go to step 9).
4. Replace left seat lower motor. See **SEAT ADJUSTER MOTORS** under REMOVAL & INSTALLATION. Recheck system operation.
5. Check for open or short to ground in Purple wire between left seat lower motor connector C2 and SCM connector C1. Repair as necessary. If circuit is okay, replace SCM. See **POWER SEAT ADJUSTER** under REMOVAL & INSTALLATION. Recheck system operation.
6. Disconnect left seat lower motor connector C2. Using DVOM, check voltage between left seat motor harness connector C2 terminal "B" (Dark Green wire) and ground. See **Fig. 4** . If reading is 3.5-5.5 volts, go to next step. If reading is not 3.5-5.5 volts, go to step 8).
7. Replace left seat lower motor. See **SEAT ADJUSTER MOTORS** under REMOVAL & INSTALLATION. Recheck system operation.
8. Check for open, short to ground or short to voltage in Dark Green wire between left seat lower motor connector C2 and SCM connector C1. Repair as necessary. If circuit is okay, replace SCM. See **POWER SEAT ADJUSTER** under REMOVAL & INSTALLATION. Recheck system operation.
9. Check for open or short to voltage in Black wire between left seat lower motor connector C2 and SCM connector C1. Repair as necessary. If circuit is okay, replace SCM. See **POWER SEAT ADJUSTER** under REMOVAL & INSTALLATION. Recheck system operation.

## REMOVAL & INSTALLATION

**CAUTION:** When battery is disconnected, vehicle computer and memory systems may lose memory data. Driveability problems may exist until computer systems have completed a relearn cycle. See **COMPUTER RELEARN PROCEDURES** article in the **GENERAL INFORMATION** section before disconnecting battery.

### POWER SEAT

#### Removal (With Adjusters)

1. Remove detachable roof lift off panel. Tilt steering wheel full up. Move seat to full rear position. Remove push pins, covers and nuts from front of adjuster legs. Move seat to full forward position.
2. If rear adjuster nuts are accessible, remove nuts securing rear adjuster legs. Lift front of seat and/or adjuster. Disconnect electrical connector. Remove seat from vehicle. **DO NOT** lift seat using lumbar pump.

## 1998 Chevrolet Corvette

SEATS - POWER 1998 ACCESSORIES & EQUIPMENT General Motors Corp. - Power Seats

3. If inoperative power seat motor is making rear adjuster nuts inaccessible, raise front of seat to gain access to forward motor bracket. Remove rivet retaining lumbar pump (if equipped). Cut tie strap, bend bracket ends inward and slide bracket off adjuster motors. Disconnect forward motor cables. Insert one end of cable into low-speed drill, and other end into adjuster. Using drill, move adjuster forward (alternating sides) until rear adjuster nuts are exposed. Remove rear adjuster nuts. Lift front of seat and/or adjuster. Disconnect electrical connector. Remove seat from vehicle. DO NOT lift seat using lumbar pump.
4. If inoperative seat adjuster is making rear adjuster nuts inaccessible, remove power seat switch. See **POWER SEAT SWITCH** . Cut tie string under bottom front center of seat cushion. Lift seat cover and foam, and remove 4 seat cushion-to-frame attaching bolts. Disconnect lumbar pump hose connectors (if equipped). Remove SCM. Disconnect seat belt harness rosebud clip (driver's seat). Remove seat from vehicle.

### Installation

To install, reverse removal procedure. Tighten adjuster nuts to 37 ft. lbs. (50 N.m).

### POWER SEAT ADJUSTER

#### Removal & Installation

1. Remove front seat. See **POWER SEAT** . Remove seat cushion cover. See **SEAT CUSHION COVER** . Remove seat cushion foam. Remove lumbar air hose connectors (if equipped).
2. Remove seat belt harness from seat frame (driver's seat). Remove SCM (if equipped). Remove buckle side of seat belt. Remove bolts mounting seat to adjusters. Remove power seat adjuster.
3. To install, reverse removal procedure. Tighten seat belt buckle side mounting nut to 37 ft. lbs. (50 N.m).

### POWER SEAT SWITCH

#### Removal & Installation

Remove recliner handle. See **SEATBACK RECLINER HANDLE** . Remove seat side trim panel. Disconnect electrical connector. Remove power seat switch. To install, reverse removal procedure. If necessary, remove front seat to install front trim panel screw. See **POWER SEAT R & I** .

### SEAT ADJUSTER MOTORS

#### Removal

1. Remove front seat. See **POWER SEAT** . Remove lumbar pump (if equipped). See **LUMBAR PUMP** . Slide front motor bracket to one side, and disconnect drive cable



## 1998 Chevrolet Corvette

SEATS - POWER 1998 ACCESSORIES & EQUIPMENT General Motors Corp. - Power Seats

from adjuster. Slide bracket from adjuster motor. Slide bracket in opposite direction. Disconnect drive cable and remove bracket from that adjuster motor.

2. Position bracket outward. Disconnect electrical harness connectors. Remove front adjuster motor. Mark location and position of rear adjuster motors for installation reference. Remove rear motors with wiring harness.

### Installation

1. Position adjuster motor and wiring harness to seat frame. Reconnect drive cables to 2 rear motors and adjuster. Install rear motor mounting screws. Install front motor to bracket. Reconnect electrical connectors.
2. Position bracket onto one adjuster motor. Insert drive cable into motor, then into transmission (turn cable as necessary to allow cable to slide into transmission).
3. Repeat previous step to install other adjuster motor. Bend bracket ends outward enough to prevent bracket from sliding off transmissions. To complete installation, reverse removal procedure.

## SEATBACK RECLINER ACTUATOR

### Removal

Remove front seat. See **POWER SEAT** . Remove seat cushion cover. See **SEAT CUSHION COVER** . Remove nuts and release cables from hinge bolts. Remove hinge bolts. Lay seatback down. Remove front actuator "E" clip and pin. Disconnect recliner cable from actuator. Remove "E" clip from rear pin. Raise seatback, and remove rear pin. See **Fig. 6** . Remove seatback recliner actuator.

### Installation

Position hinge on actuator with arrow on hinge pointed forward. Install rear pin and "E" clip. Connect recliner cable with tab up. To complete installation, reverse removal procedure.

## LUMBAR BLADDER

### Removal

1. Remove front seat. See **POWER SEAT** . Remove seat cushion cover. See **SEAT CUSHION COVER** . Remove seatback insert pillow. See **SEATBACK COVER (SPORT SEAT)** .
2. Disconnect bladder hose connector from lumbar pump. Slide upper lumbar bladder up slightly, tuck mounting tab under bladder sleeve, and slide bladder down over tab. Slide lower lumbar bladder up slightly, tuck mounting tab under bladder sleeve, and slide bladder down over tab. Slide air hoses from under seatback cover. Remove lumbar bladders.

### Installation

## 1998 Chevrolet Corvette

SEATS - POWER 1998 ACCESSORIES & EQUIPMENT General Motors Corp. - Power Seats

Slide lower bladder sleeve up over mounting tab, pull tab out over bladder sleeve, and slide bladder slightly downward. Slide upper bladder sleeve up over mounting tab, pull tab out over bladder sleeve, and slide bladder slightly downward. Tuck hoses under corner of seatback cover foam. To complete installation, reverse removal procedure.

### LUMBAR PUMP

#### Removal & Installation

Remove front seat. See **POWER SEAT** . Remove rivet attaching pump to seat bracket. Disengage rear mounting tabs on pump from seat, and slide pump forward. Disconnect electrical connectors. Disconnect air hose connectors. Remove lumbar pump. To install, reverse removal procedure.

### SEATBACK RECLINER HANDLE

#### Removal & Installation

Push seat cushion in to expose handle to shaft retaining clip. Insert blunt-ended tool between cushion and recliner handle. Push recliner handle retaining spring clip down, and pull handle from shaft. See **Fig. 6** . To install, position handle retaining spring clip into lock position and snap handle onto reclining mechanism shaft.

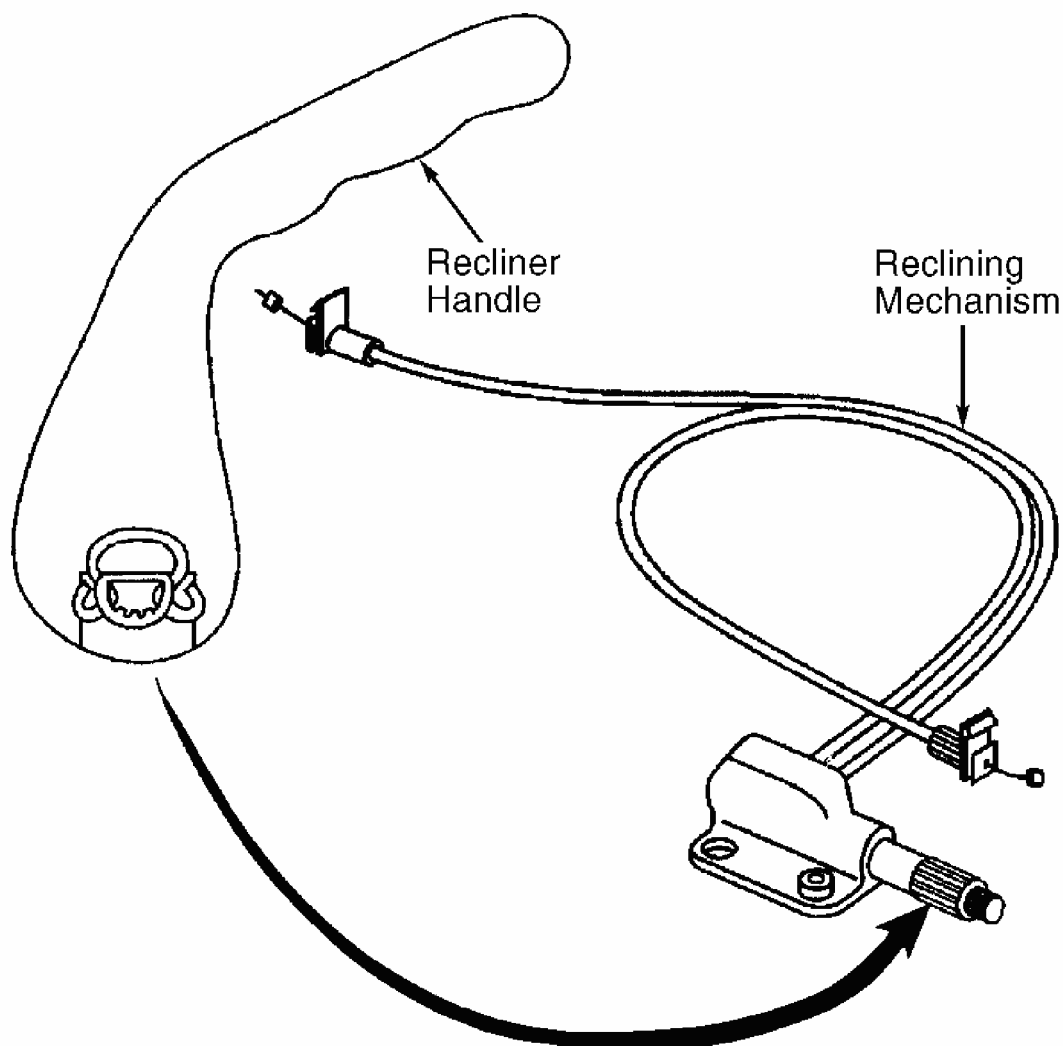

G98H12226

**Fig. 6: Identifying Recliner Mechanism Components**  
Courtesy of GENERAL MOTORS CORP.

### SEAT CUSHION COVER

#### Removal

1. Remove front seat. See **POWER SEAT** . Remove seatback recliner handle. See **SEATBACK RECLINER HANDLE** . Remove power seat switch. See **POWER SEAT SWITCH** .
2. Remove hog rings from rear flap. Unfasten draw string, and remove hog rings attaching rear corners of seat cushion cover. Remove seat cushion cover.

#### Installation

## 1998 Chevrolet Corvette

SEATS - POWER 1998 ACCESSORIES & EQUIPMENT General Motors Corp. - Power Seats

1. If draw string was not cut, go to next step. If draw string was cut, remove hog rings attaching seat cushion cover rear flap. Untie draw string. Make a very small cut in cushion cover just in front of where draw string receded when it was cut. Pull draw string out enough to securely tie ends together.
2. With seat cushion cover properly positioned over foam and seat frame, tighten draw string at rear of seat and tie securely. Install hog rings attaching rear side corners of seat cushion cover. Install hog rings attaching rear center flap.
3. If draw string was cut and step 1) was performed, wrap front seat material around draw string and hog ring material to string. Ensure no sharp points of hog rings are pointed down. To complete installation, reverse removal procedure.

### SEATBACK COVER (SPORT SEAT)

#### Removal

1. Remove front seat. See **POWER SEAT** . Unzip zipper at top of pillow insert. Undo insert pillow lower "J" strips. Tip side of insert pillow out to access upper side christmas tree fasteners attaching cover to seat frame. Slightly raise fasteners, and slide cover tabs out from under fasteners. Slide insert pillow tabs out from under fasteners, and remove insert pillow.
2. Slightly raise christmas tree fasteners attaching seatback cover to seat frame. Slide cover tabs out from under fasteners. Unzip seatback cover upper zipper. Pull seatback cover up over headrest. Remove christmas tree fasteners from foam upper retaining strap, and remove foam.
3. Remove seatback release lever. Remove bezel and cover from release lever. Remove bezel from seatback cover.

#### Installation

To install, reverse removal procedure. Ensure christmas tree fasteners are pushed in tight.

### WIRING DIAGRAMS

# 1998 Chevrolet Corvette

## SEATS - POWER 1998 ACCESSORIES & EQUIPMENT General Motors Corp. - Power Seats

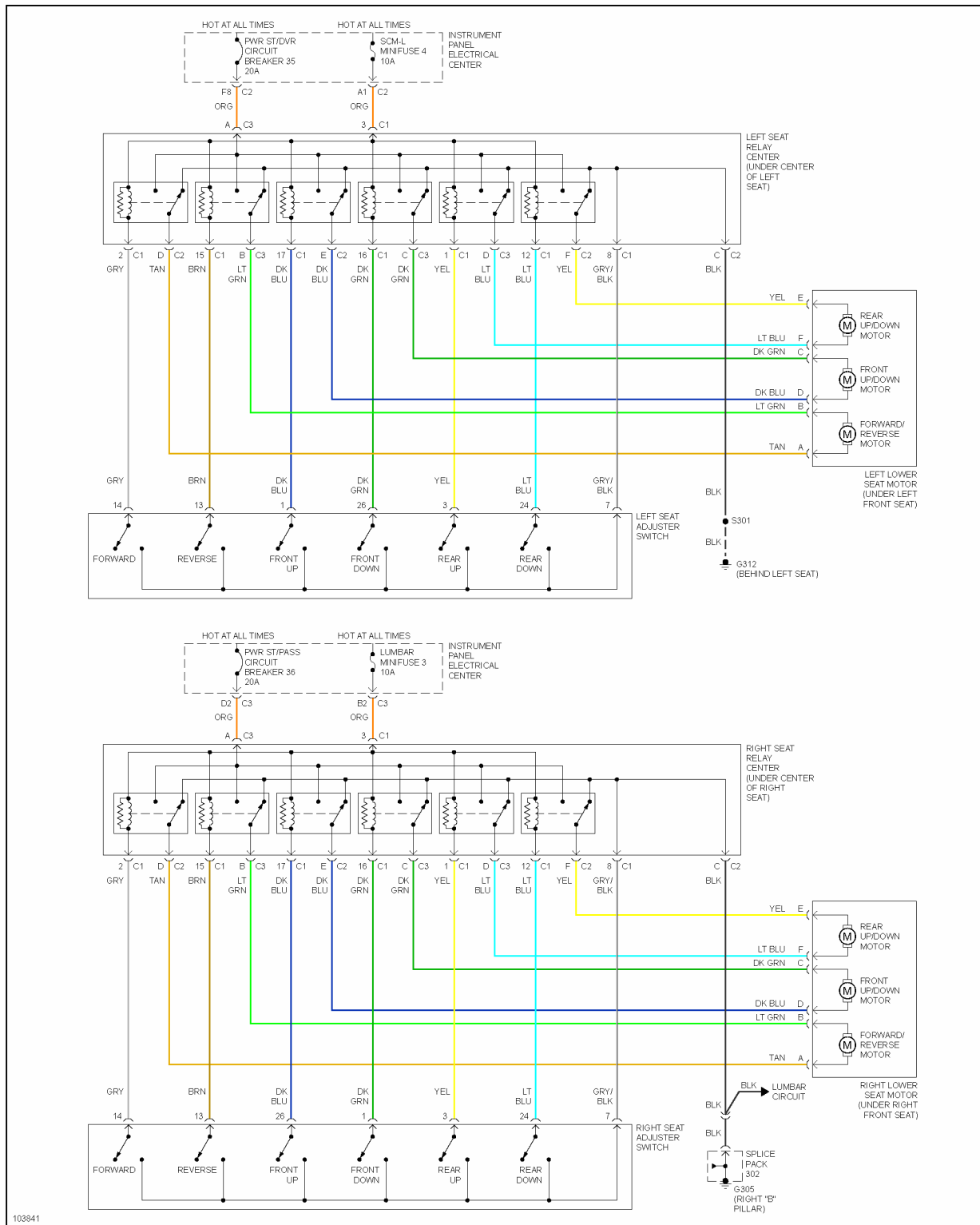
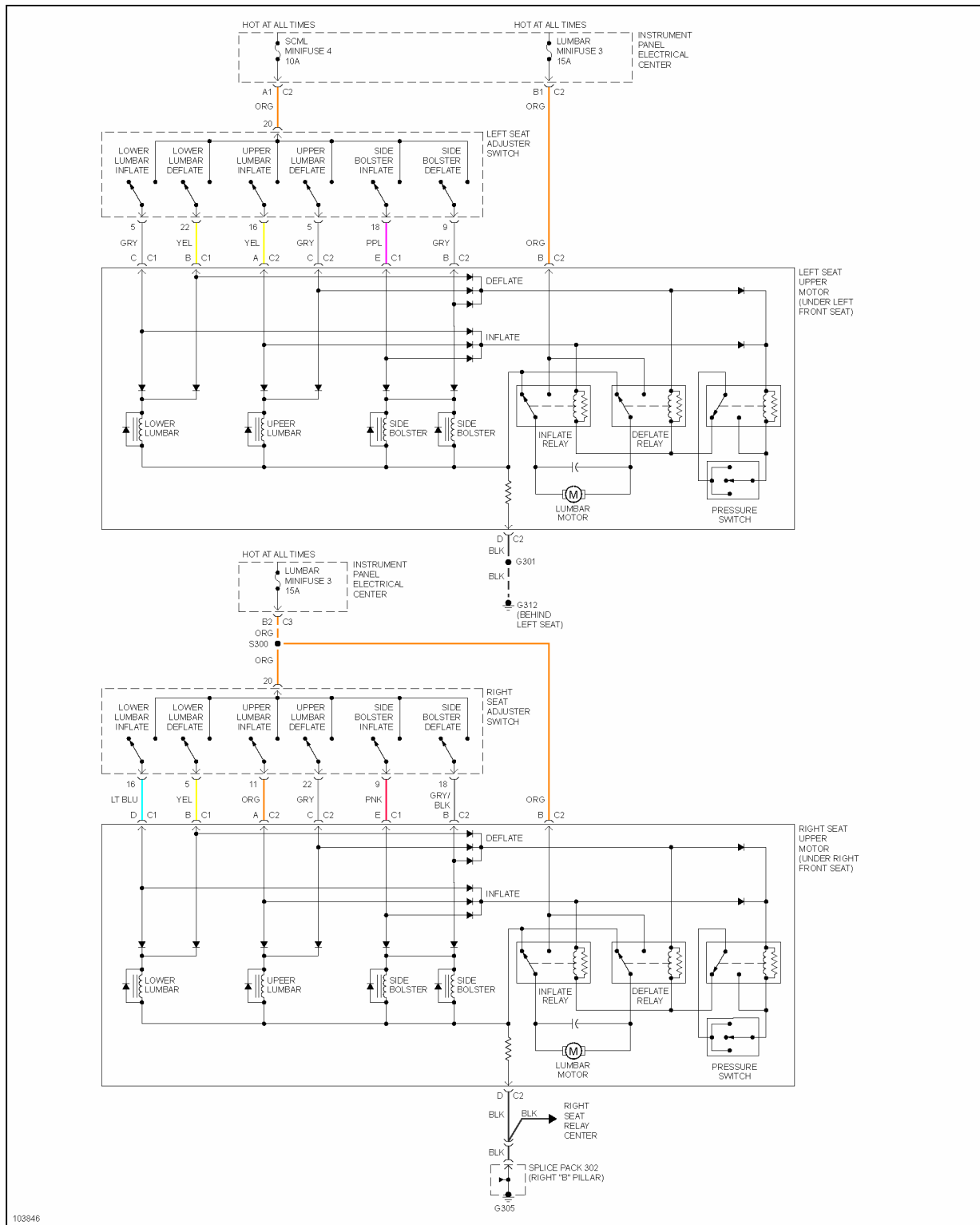

Fig. 7: Power Seats Wiring Diagram

# 1998 Chevrolet Corvette

## SEATS - POWER 1998 ACCESSORIES & EQUIPMENT General Motors Corp. - Power Seats



**Fig. 8: Power Lumbar Seats Wiring Diagram**