

POWER WINDOWS

1997-98 ACCESSORIES & EQUIPMENT General Motors Corp. - Power Windows

DESCRIPTION

Power window system uses a permanent-magnet motor to operate each window. Motor operation is controlled by Left Door Control Module (LDCM) or Right Door Control Module (RDCM). Window is raised or lowered depending on polarity of current applied to window motor.

OPERATION

When ignition switch is in RUN position, power for window system is supplied to left and right Door Control Modules (LDCM and RDCM) through fuses No. 30, 31, 33 and 34. Left window switch controls both left and right window functions. Express down feature is driver side only feature in 1997 and both a driver side and passenger side feature in 1998. Feature allows left or right front window to be fully opened by pressing appropriate front window switch down to second detent. Express travel can be stopped at any position by momentarily pressing either switch to UP or DOWN position. Window switches provide a ground signal to control module when operated.

COMPONENT LOCATIONS

COMPONENT LOCATIONS

Component	Location
Body Control Module	Right Footwell, Mounted To Toeboard Behind Carpet
Data Link Connector	Left Side Of Instrument Panel, Below Steering Column
Door Control Module (DCM)	Behind Bottom Center Of Door Trim Panel
Instrument Panel	Right Footwell, Mounted
Electrical Center	To Toeboard Behind Carpet
Underhood Electrical Center	Right Rear Corner Of Engine Compartment, Between Battery & Coolant Reservoir

TROUBLE SHOOTING

PRELIMINARY CHECK

1. Using scan tool, attempt to establish communication with door control modules. If communication is not successful, repair serial data link fault first. See **WIRING DIAGRAMS** . If communication with modules is successful, retrieve all Diagnostic

Trouble Codes (DTCs). Perform necessary repairs if DTCs exist. See **DTC DEFINITIONS** table under SELF-DIAGNOSTICS.

2. If both windows are inoperative from left switch, Check fuses No. 30, 31, 33 and 34. Replace as necessary.
3. If windows move slowly, ensure battery is fully charged, terminal contact and ground connections are okay. Ground points are located behind left and right kick panels. Check window regulator lubrication. Ensure aftermarket equipment is properly installed.

POWER WINDOW SYSTEM CHECK

NOTE: See appropriate system test for abnormal symptom. Ensure cause of DTCs is cleared before trouble shooting other problems.

1. With ignition switch in RUN position, operate each window up and down from left door power window switch. Each window should operate quietly and smoothly, with no sticking.
2. Operate each window from individual window switch. Each window should operate quietly and smoothly, with no sticking. Each window should travel down fully without switch being held (express down feature).

SYSTEM TESTS

CAUTION: To prevent damage to terminals, connector Test Adaptor Kit (J-35616-A) must be used whenever a diagnostic procedure requires checking or probing terminals. To locate and identify terminals, see **WIRING DIAGRAMS** .

LEFT FRONT POWER WINDOW INOPERATIVE

1. Using scan tool, check LDCM history for DTCs. If DTC B2202, B2204 or B2274 is stored as history, go to applicable DTC. If no DTCs are stored, go to next step.
2. Using scan tool, select LDCM and command left window up and down. If window operates as commanded, go to step 4). If window does not operate as commanded, go to next step.
3. Turn ignition switch to OFF position. Disconnect left window motor connector. Turn ignition switch to RUN position. Connect test light between left window motor connector terminals "A" (Dark Blue wire) and "B" (Brown wire). Using scan tool, command left window UP and DOWN. If test light illuminates with each command, go to step 10). If test light does not illuminate with each command, go to next step 6).
4. Using scan tool, select LDCM inputs and monitor driver window switch status. Depress left window switch to UP position. If scan tool displays driver window UP switch as ACTIVE, go to next step. If scan tool does not display driver window UP switch as

1998 Chevrolet Corvette

POWER WINDOWS 1997-98 ACCESSORIES & EQUIPMENT General Motors Corp. - Power Windows

- ACTIVE, go to step 7).
- Using scan tool, select LDCM inputs and monitor driver window switch status. Depress left window switch to DOWN position. If scan tool displays driver window DOWN switch as ACTIVE, system is okay. If scan tool does not display driver window DOWN switch as ACTIVE, go to step 8).
 - Repair open or short in Dark Blue or Brown wire between left power window motor and LDCM. After, repair go to step 12). If circuits are okay, go to step 10).
 - Repair open in Brown or Black wire between LDCM and Left door power window switch. After repair, go to step 12). If circuits are okay, go to step 11).
 - Repair open in Gray or Black wire between LDCM and left door power window switch. After repair, go to step 12). If circuits are okay, go to step 11).
 - Replace left power window motor. See **WINDOW MOTOR** under REMOVAL & INSTALLATION.
 - Replace LDCM. See **COMPONENT LOCATIONS** table.
 - Replace left door switch assembly. See **WINDOW SWITCH** under REMOVAL & INSTALLATION.
 - Turn ignition switch to OFF position. Reconnect or install any connectors or components that were disconnected or removed. Turn ignition switch to ON position. Clear any DTCs. See **CLEARING DIAGNOSTIC TROUBLE CODES (DTCs)** . Recheck system operation.

RIGHT WINDOW INOPERATIVE FROM LEFT SWITCH

- Using scan tool, check LDCM history for DTCs. If DTC B2205, B2206 or B2208 is stored as history, go to applicable DTC. If no DTCs are stored, go to next step.
- Depress right window switch UP and DOWN. If right window operates, go to next step. If right window does not operate, refer to **RIGHT POWER WINDOW INOPERATIVE** .
- Using left window switch, depress right switch window up and down. If right window operates up and down, system is okay. If right window does not operate, go to next step.
- Using scan tool, select LDCM inputs and monitor passenger window switch status. Using left window switch, depress right window switch to UP position. If scan tool display shows UP status ACTIVE, go to next step. If scan tool display does not show ACTIVE, go to step 7).
- Using scan tool, select LDCM inputs and monitor passenger window switch status. Using left window switch, depress right window switch to DOWN position. If scan tool displays DOWN status ACTIVE, system is okay. If scan tool does not display ACTIVE, go to next step.
- Repair open in Tan or Black wire between LDCM and left door switch. After repair go to step 9). If circuits are okay, go to step 8).

1998 Chevrolet Corvette

POWER WINDOWS 1997-98 ACCESSORIES & EQUIPMENT General Motors Corp. - Power Windows

7. Repair open in Light Blue or Black wire between LDCM and left door switch. After repair go to step 9). If circuits are okay, go to next step.
8. Replace left door switch assembly. See **WINDOW SWITCH** under REMOVAL & INSTALLATION.
9. Turn ignition switch to OFF position. Reconnect or install any connectors or components that were disconnected or removed. Turn ignition switch to ON position. Clear any DTCs. See **CLEARING DIAGNOSTIC TROUBLE CODES (DTCs)** . Recheck system operation.

RIGHT POWER WINDOW INOPERATIVE

1. Using scan tool, check LDCM history for DTCs. If DTC B2203, B2205 or B2275 is stored as history, go to applicable DTC. If no DTCs are stored, go to next step.
2. Using scan tool, select RDCM and command right window up and down. If window operates as commanded, go to step 4). If window does not operate as commanded, go to next step.
3. Turn ignition switch to OFF position. Disconnect right window motor connector. Turn ignition switch to RUN position. Connect test light between right window motor connector terminals "A" (Dark Blue wire) and "B" (Brown wire). Using scan tool, command right window up and down. If test light illuminates with each command, go to step 10). If test light does not illuminate with each command, go to next step 6).
4. Using scan tool, select RDCM inputs and monitor passenger window switch status. Depress right window switch to UP position. If scan tool displays passenger window UP switch as ACTIVE, go to next step. If scan tool does not display driver window UP switch as ACTIVE, go to step 7).
5. Using scan tool, select LDCM inputs and monitor passenger window switch status. Depress right window switch to DOWN position. If scan tool displays passenger window DOWN switch as ACTIVE, system is okay. If scan tool does not display passenger window DOWN switch as ACTIVE, go to step 8).
6. Repair open or short in Dark Blue or Brown wire between left power window motor and LDCM. After, repair go to step 12). If circuits are okay, go to step 10).
7. Repair open in Light Blue or Black wire between RDCM and right door power window switch. After repair, go to step 12). If circuits are okay, go to step 11).
8. Repair open in Tan or Black wire between RDCM and right door power window switch. After repair, go to step 12). If circuits are okay, go to step 11).
9. Replace right power window motor. See **WINDOW MOTOR** under REMOVAL & INSTALLATION.
10. Replace RDCM. See **COMPONENT LOCATION** table.
11. Replace left door switch assembly. See **WINDOW SWITCH** under REMOVAL & INSTALLATION.
12. Turn ignition switch to OFF position. Reconnect or install any connectors or

components that were disconnected or removed. Turn ignition switch to ON position. Clear any DTCs. See **CLEARING DIAGNOSTIC TROUBLE CODES (DTCS)** . Recheck system operation.

SELF-DIAGNOSTICS

RETRIEVING DIAGNOSTIC TROUBLE CODES (DTCS)

Using On-Board Diagnostics

If any warning messages exist, depress RESET button. Depress and hold OPTIONS button and press FUEL button 4 times within 5 seconds of depressing the OPTIONS button. Module number and module name will appear on Driver's Information Center (DIC) display. Module number for the Left Door Control Module (LDCM) is A0, module number for Right Door Control Module (RCDM) is A1. After module is displayed, individual DTCs will be displayed.

To begin manual control of DTC viewing, depress FUEL, TRIP, GAUGES, OPTIONS or RESET button. Depress TRIP button to view previous module. Depress OPTIONS button to view next module. Depress FUEL button to view previous DTC in selected module. Depress GAUGES button to view next DTC in selected module. After retrieving and recording current and history DTCs, proceed to appropriate DTC and follow diagnostic and repair procedures. Depress E/M button to exit self-diagnostics.

Using Scan Tool

Diagnostic Trouble Codes (DTCs) can also be retrieved using scan tool. Connect scan tool to Data Link Connector (DLC) located under driver's side of instrument panel. Turn ignition switch to ON position. Select appropriate module on scan tool display to retrieve current and history DTCs. Record DTCs and proceed to appropriate DTC and follow diagnostic and repair procedures.

CLEARING DIAGNOSTIC TROUBLE CODES (DTCS)

Seat Control Module (SCM) DTCs can be cleared by using IPC clearing feature, using a scan tool, or will automatically clear if malfunction has not occurred within 50 ignition cycles.

Using On-Board Diagnostics

Use manual control functions to select and view DTC. See **RETRIEVING DIAGNOSTIC TROUBLE CODES (DTCS)** . Depress reset button for 2 seconds to clear selected DTC from selected module.

Using Scan Tool

Select CLEAR DTCs function on scan tool. Clear current and history DTCs. Operate vehicle

1998 Chevrolet Corvette

POWER WINDOWS 1997-98 ACCESSORIES & EQUIPMENT General Motors Corp. - Power Windows

and recheck for DTCs.

DTC DEFINITIONS

DTC	Description
B2202	Left Window Up Switch Fault (LDCM)
B2203	Right Window Up Switch Fault (RDCM)
B2204	Left Window Down Switch Fault (LDCM)
B2205	Right Window Down Switch Fault (RDCM)
B2206	Right Window Up Switch Fault (LDCM)
B2208	Right Window Down Switch Fault (LDCM)
B2274	Left Window Motor Fault (LDCM)
B2275	Right Window Motor Fault (RDCM)
B2282	Battery No. 1 Fault (LDCM)
B2283	Battery No. 1 Fault (RDCM)
B2284	Battery No. 2 Fault (LDCM)
B2285	Battery No. 2 Fault (RDCM)

DIAGNOSTIC TESTS (1997 MODELS)

CAUTION: To prevent damage to terminals, Connector Test Adaptor Kit (J-35616-A) must be used whenever a diagnostic procedure requires checking or probing terminals. To identify terminals, see WIRING DIAGRAMS .

DTC B2202: LEFT WINDOW UP SWITCH FAULT (LDCM)

Testing

1. Disconnect LDCM White, 26-pin harness connector C4. Using DVOM, measure resistance at DCM connector C4 terminals No. 7 (Brown wire) and No. 9 (Black wire) while pressing left door left window switch to UP position. See [Fig. 1](#) . If resistance is less than 5 ohms, go to next step. If resistance is more than 5 ohms, go to step 3).
2. Replace LDCM. Recheck system operation.
3. Disconnect left door switch White, 26-pin connector C4. Using DVOM, measure resistance at left door switch connector C4 terminals No. 7 (Brown wire) and No. 9 (Black wire) while pressing left door left window switch to UP position. If resistance is less than 5 ohms, go to next step. If resistance is more than 5 ohms, go to step 5).
4. Repair on in Brown or Black wire between left door control module and left door switch. Recheck system operation.
5. Replace left door switch. Recheck system operation.

DTC B2203: RIGHT WINDOW UP SWITCH FAULT (RDCM)

1998 Chevrolet Corvette

POWER WINDOWS 1997-98 ACCESSORIES & EQUIPMENT General Motors Corp. - Power Windows

Testing

1. Disconnect RDCM 26-pin harness connector C4. Using DVOM, measure resistance at RDCM connector C4 terminals No. 9 (Black wire) and No. 7 (Light Blue wire) while pressing right door window switch to UP position. See **Fig. 1** . If resistance is less than 5 ohms, go to next step. If resistance is more than 5 ohms, go to step 3).
2. Replace RDCM. Recheck system operation.
3. Disconnect right door switch 7-pin connector C1. Using DVOM, measure resistance at right door switch connector C1 terminals No. 5 (Black wire) and No. 4 (Light Blue wire) while pressing right door window switch to UP position. See **Fig. 2** . If resistance is less than 5 ohms, go to next step. If resistance is more than 5 ohms, go to step 5).
4. Repair on in Black or Light Blue wire between right door control module and right door switch. Recheck system operation.
5. Replace right door switch. Recheck system operation.

DTC B2204: LEFT WINDOW DOWN SWITCH FAULT (LDCM)

Testing

1. Disconnect LDCM White, 26-pin harness connector C4. Using DVOM, measure resistance at DCM connector C4 terminals No. 8 (Gray wire) and No. 9 (Black wire) while pressing left door left window switch to DOWN position. See **Fig. 1** . If resistance is less than 5 ohms, go to next step. If resistance is not less than 5 ohms, go to step 3).
2. Replace LDCM. Recheck system operation.
3. Disconnect left door switch 26-pin harness connector C4. Using DVOM, measure resistance at left door switch connector C4 terminals No. 8 (Gray wire) and No. 9 (Black wire) while pressing left door left window switch to DOWN position. If resistance is less than 5 ohms, go to next step. If resistance is not less than 5 ohms, go to step 5).
4. Repair on in Gray or Black wire between left door control module and left door switch. Recheck system operation.
5. Replace left door switch. Recheck system operation.

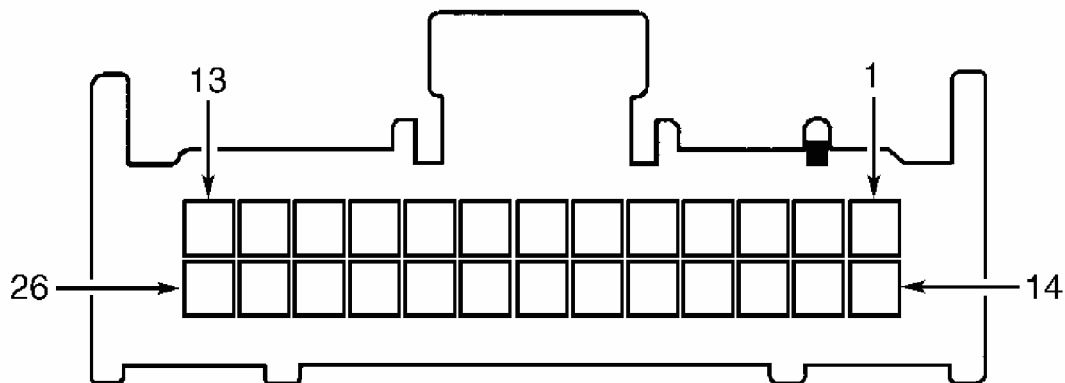

G98A12443

Fig. 1: Identifying Door Control Modules Connectors C1 & C4 & Left Window Switch Connector Terminals
Courtesy of GENERAL MOTORS CORP.

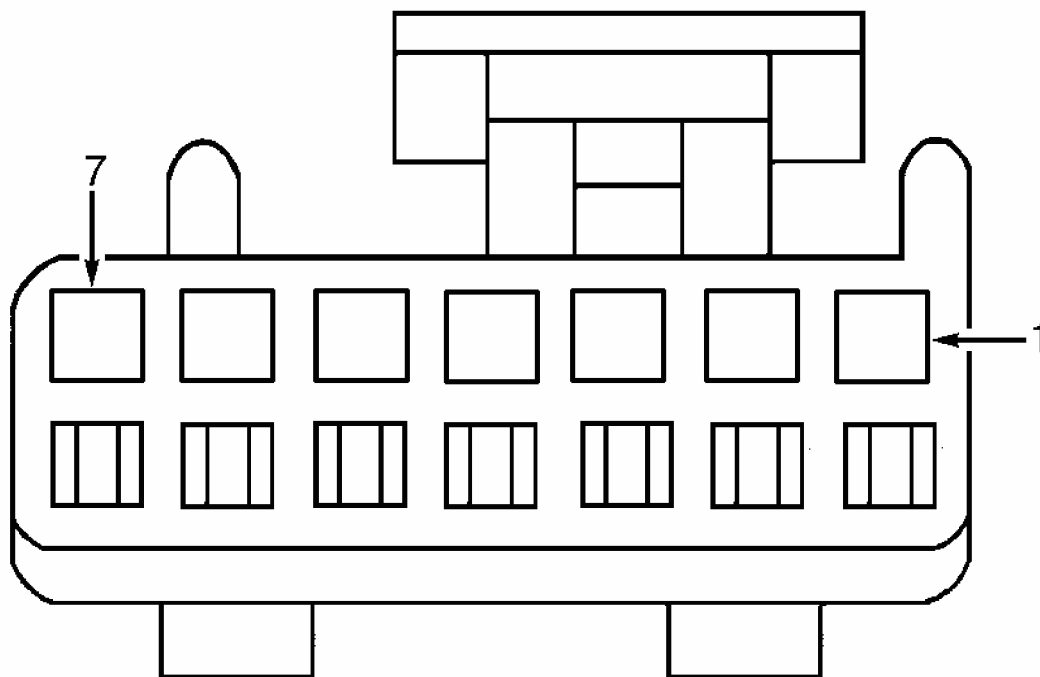

G98C12445

Fig. 2: Identifying Right Door Window Switch Connector C1 Terminals
Courtesy of GENERAL MOTORS CORP.

DTC B2205: RIGHT WINDOW DOWN SWITCH FAULT (RDCM)

1998 Chevrolet Corvette

POWER WINDOWS 1997-98 ACCESSORIES & EQUIPMENT General Motors Corp. - Power Windows

Testing

1. Disconnect RDCM 26-pin harness connector C4. Using DVOM, measure resistance at DCM connector C4 terminals No. 9 (Black wire) and No. 8 (Tan wire) while pressing right door window switch to DOWN position. See **Fig. 1** . If resistance is less than 5 ohms, go to next step. If resistance is not less than 5 ohms, go to step 3).
2. Replace RDCM. Recheck system operation.
3. Disconnect right door switch 7-pin harness connector C1. Using DVOM, measure resistance at right door switch connector C1 terminals No. 5 (Black wire) and No. 7 (Tan wire) while pressing right door window switch to DOWN position. If resistance is less than 5 ohms, go to next step. If resistance is not less than 5 ohms, go to step 5).
4. Repair on in Black or Tan wire between right door control module and right door switch. Recheck system operation.
5. Replace right door switch. Recheck system operation.

DTC B2206: RIGHT WINDOW UP SWITCH FAULT (LDCM)

Testing

1. Disconnect LDCM White, 26-pin harness connector C4. Using DVOM, measure resistance at DCM connector C4 terminals No. 9 (Black wire) and No. 24 (Light Blue wire) while pressing left door right window switch to UP position. See **Fig. 1** . If resistance is less than 5 ohms, go to next step. If resistance is not less than 5 ohms, go to step 3).
2. Replace LDCM. Recheck system operation.
3. Disconnect left door switch White, 26-pin harness connector C4. Using DVOM, measure resistance at right door switch connector C4 terminals No. 9 (Black wire) and No. 24 (Light Blue wire) while pressing left door right window switch to UP position. If resistance is less than 5 ohms, go to next step. If resistance is not less than 5 ohms, go to step 5).
4. Repair on in Black or Light Blue wire between right door control module and right door switch. Recheck system operation.
5. Replace left door switch. Recheck system operation.

DTC B2208: RIGHT WINDOW DOWN SWITCH FAULT (LDCM)

Testing

1. Disconnect LDCM White, 26-pin harness connector C4. Using DVOM, measure resistance at DCM connector C4 terminals No. 9 (Black wire) and No. 25 (Tan wire) while pressing left door right window switch DOWN. See **Fig. 1** . If resistance is less than 5 ohms, go to next step. If resistance is not less than 5 ohms, go to step 3).
2. Replace LDCM. Recheck system operation.

1998 Chevrolet Corvette

POWER WINDOWS 1997-98 ACCESSORIES & EQUIPMENT General Motors Corp. - Power Windows

3. Disconnect left door switch White, 26-pin harness connector C4. Using DVOM, measure resistance at left door switch connector C4 terminals No. 9 (Black wire) and No. 25 (Tan wire) while pressing left door right window switch UP. If resistance is less than 5 ohms, go to next step. If resistance is not less than 5 ohms, go to step 5).
4. Repair on in Black or Tan wire between right door control module and right door switch. Recheck system operation.
5. Replace left door switch. Recheck system operation.

DTC B2274: LEFT WINDOW MOTOR FAULT (LDCM)

Testing

1. Disconnect left window motor. Connect DVOM from left window motor terminals "A" (Dark Blue wire) and "B" (Brown wire). Move left window switch to UP and DOWN positions. If 10-14 volts exists in both positions, go to next step. If 10-14 volts does not exist in both positions, go to step 3).
2. Replace left window motor. Recheck system operation.
3. Repair open in Dark Blue wire and Brown wire between left window motor and left door control module.

DTC B2275: RIGHT WINDOW MOTOR FAULT (RDCM)

Testing

1. Disconnect right window motor. Connect DVOM from right window motor terminals "A" (Dark Blue wire) and "B" (Brown wire). Move right window switch to UP and DOWN positions. If 10-14 volts exists in both positions, go to next step. If 10-14 volts does not exist in both positions, go to step 3).
2. Replace right window motor. Recheck system operation.
3. Repair open in Dark Blue wire and Brown wire between right window motor and right door control module.

DTC B2282: BATTERY NO. 1 FAULT (LDCM)

Testing

1. Disconnect LDCM White, 26-pin harness connector C1. Measure voltage between ground and left door control module connector C1 terminal No. 1 (Orange wire). See **Fig. 1** . If 10-14 volts exists, go to next step. If 10-14 volts does not exist, go to step 3).
2. Replace LDCM. Recheck system operation.
3. Disconnect 6-pin connector C201. Measure voltage between ground and connector C201 terminal "C" (Orange wire). If 10-14 volts exists, go to next step. If 10-14 volts does not exist, go to step 5).
4. Repair open in Orange wire between connector C201 and left door control module.

1998 Chevrolet Corvette

POWER WINDOWS 1997-98 ACCESSORIES & EQUIPMENT General Motors Corp. - Power Windows

Recheck system operation.

5. Disconnect instrument panel electrical center connector C1. Measure voltage between ground and instrument panel electrical center connector C1 terminal C12 (Orange wire). If 10-14 volts exists, go to next step. If 10-14 volts does not exist, go to step 7).
6. Repair open in Orange wire between connector C201 and instrument panel electrical. Recheck system operation.
7. Replace instrument panel electrical center. Recheck system operation.

DTC B2283: BATTERY NO. 1 FAULT (RDCM)

Testing

1. Disconnect RDCM 26-pin harness connector C1. Measure voltage between ground and right door control module connector C1 terminal No. 1 (Orange wire). See **Fig. 1** . If 10-14 volts exists, go to next step. If 10-14 volts does not exist, go to step 3).
2. Replace RDCM. Recheck system operation.
3. Disconnect 6-pin connector C200. Measure voltage between ground and connector C200 terminal "C" (Orange wire). If 10-14 volts exists, go to next step. If 10-14 volts does not exist, go to step 5).
4. Repair open in Orange wire between connector C200 and right door control module. Recheck system operation.
5. Disconnect instrument panel electrical center connector C1. Measure voltage between ground and instrument panel electrical center connector C1 terminal C11 (Orange wire). If 10-14 volts exists, go to next step. If 10-14 volts does not exist, go to step 7).
6. Repair open in Orange wire between connector C200 and instrument panel electrical. Recheck system operation.
7. Replace instrument panel electrical center. Recheck system operation.

DTC B2284: BATTERY NO. 2 FAULT (LDCM)

Testing

1. Disconnect LDCM Black, 6-pin harness connector C3. Measure voltage between ground and left door control module connector C3 terminal "A" (Orange wire). See **Fig. 3** . If 10-14 volts exists, go to next step. If 10-14 volts does not exist, go to step 3).
2. Replace LDCM. Recheck system operation.
3. Disconnect 6-pin connector C201. Measure voltage between ground and connector C201 terminal "A" (Orange wire). If 10-14 volts exists, go to next step. If 10-14 volts does not exist, go to step 5).
4. Repair open in Orange wire between connector C201 and LDCM. Recheck system operation.
5. Disconnect instrument panel electrical center connector C1. Measure voltage between

ground and instrument panel electrical center connector C1 terminal B12 (Orange wire). If 10-14 volts exists, go to next step. If 10-14 volts does not exist, go to step 7).

6. Repair open in Orange wire between connector C201 and instrument panel electrical. Recheck system operation.
7. Replace instrument panel electrical center. Recheck system operation.

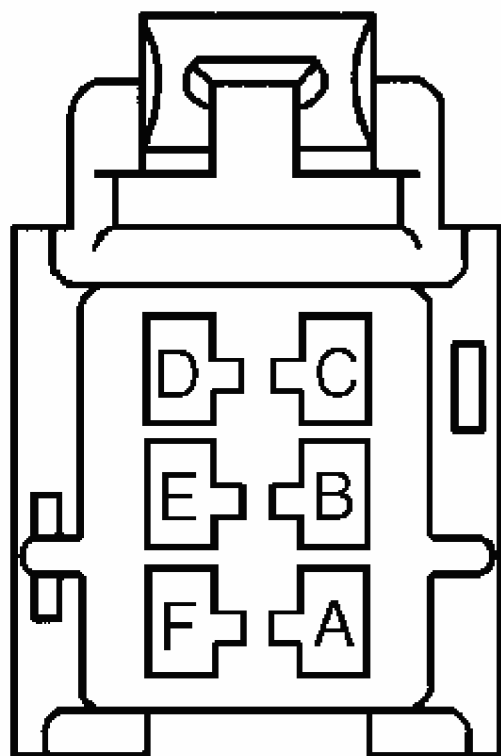

G98B12444

Fig. 3: Door Control Module Connector C3 Connector Terminals
Courtesy of GENERAL MOTORS CORP.

DTC B2285: BATTERY NO. 2 FAULT (RDCM)

Testing

1. Disconnect RDCM Black, 6-pin harness connector. Measure voltage between ground and right door control module connector C3 terminal "A" (Orange wire). See **Fig. 3** . If 10-14 volts exists, go to next step. If 10-14 volts does not exist, go to step 3).
2. Replace RCDM. Recheck system operation.

3. Disconnect 6-pin connector C200. Measure voltage between ground and connector C200 terminal "A" (Orange wire). If 10-14 volts exists, go to next step. If 10-14 volts does not exist, go to step 5).
4. Repair open in Orange wire between connector C200 and RCDM. Recheck system operation.
5. Disconnect instrument panel electrical center connector C1. Measure voltage between ground and instrument panel electrical center connector C1 terminal B11 (Orange wire). If 10-14 volts exists, go to next step. If 10-14 volts does not exist, go to step 7).
6. Repair open in Orange wire between connector C200 and instrument panel electrical center. Recheck system operation.
7. Replace instrument panel electrical center. Recheck system operation.

DIAGNOSTIC TESTS (1998 MODELS)

CAUTION: To prevent damage to terminals, connector Test Adaptor Kit (J-35616-A) must be used whenever a diagnostic procedure requires checking or probing terminals. To locate and identify terminals, see WIRING DIAGRAMS .

DTC B2202: LEFT WINDOW UP SWITCH FAULT (LDCM)

Circuit Description

Left door switch circuit provides input to left door control module (LDCM) when left window switch is depressed to UP or DOWN position. This input allows LDCM to detect a left window up or down request. LDCM provides both power and ground to window switches. When left window switch is depressed to UP or DOWN position, ground is supplied through left window switch to left window up or down switch input is pulled low. When LDCM detects low voltage on left window up or down switch input, LDCM will command left window up or down. When switch is released, LDCM will command left window to stop (window express down feature down not activated). LDCM monitors both left window input circuits and determines how long ground had been applied. If ground is applied for longer than expected, a malfunction is present and a DTC will set.

DTC B2202 will set if LDCM detects a low voltage level (short to ground) at left window down switch input circuit. This condition must exist for more than 20 seconds. DTC B2202 will store as a history code in LDCM memory. No driver warning will be displayed.

Under all fault conditions, DTC B2202 will clear automatically when LDCM no longer detects a low voltage level (short to ground) at left window down switch input circuit for longer than 20 seconds. Current and history DTCs can be cleared using scan tool or IPC clearing DTCs feature.

Testing

1998 Chevrolet Corvette

POWER WINDOWS 1997-98 ACCESSORIES & EQUIPMENT General Motors Corp. - Power Windows

1. Using scan tool, select LDCM input display and monitor driver window status. If scan tool displays driver window UP status as ACTIVE, go to next step. If scan tool does not display driver window UP status as ACTIVE, go to step 6).
2. Disconnect left door window switch. Using scan tool, select LDCM input display and monitor driver side window UP switch status. If scan tool display shows driver window UP status as ACTIVE, go to next step. If scan tool display shows driver window UP switch as INACTIVE, go to step 4).
3. Check for short to ground in Brown wire between left door window switch and LDCM. Repair as necessary. After repair go to step 8). If circuit is okay, go to step 5).
4. Replace left door window switch assembly. Go to step 8).
5. Replace LDCM. Go to step 8).
6. Check left door window switch for intermittent malfunction. See **DIAGNOSTIC AIDS**. If problem is found and repaired, go to step 8). If no problem is found, go to next step.
7. Turn ignition switch to OFF position. Reconnect or install any connectors or components that were disconnected or removed. Clear any DTCs. See **CLEARING DIAGNOSTIC TROUBLE CODES (DTCS)** . Wait 20 seconds. Check for DTCs. If DTC B2202 sets as history again, go to step 5). If DTC B2202 does not reset, system is okay.
8. Turn ignition switch to OFF position. Reconnect or install any connectors or components that were disconnected or removed. Turn ignition switch to ON position. Clear any DTCs. See **CLEARING DIAGNOSTIC TROUBLE CODES (DTCS)** . Recheck system operation.

Diagnostic Aids

Following conditions may cause an intermittent malfunction:

- Intermittent short to ground in left window UP switch input circuit (Brown wire).
- Left window UP switch is shorted to ground internally or is sticking.
- Left window UP switch was depressed for longer than 20 seconds.
- If Brown wire is shorted to ground or left window down switch is stuck closed, left window will remain up at all times.
- Using scan tool, select LDCM inputs and monitor driver window up switch status. If scan tool displays ACTIVE, disconnect left window switch. If status did not change, check Brown wire for short to ground.

DTC B2203: RIGHT WINDOW UP SWITCH FAULT (RDCM)

Circuit Description

Right door switch circuit provides input to right door control module (RDCM) when right window switch is depressed to UP or DOWN position. This input allows RDCM to detect a

1998 Chevrolet Corvette

POWER WINDOWS 1997-98 ACCESSORIES & EQUIPMENT General Motors Corp. - Power Windows

right window up or down request. RDCM provides both power and ground to window switches. When right window switch is depressed to UP or DOWN position, ground is supplied through right window switch to left window up or down switch input is pulled low. When RDCM detects low voltage on right window up or down switch input, RDCM will command right window up or down. When switch is released, RDCM will command right window to stop (window express down feature down not activated). RDCM monitors both left window input circuits and determines how long ground had been applied. If ground is applied for longer than expected, a malfunction is present and a DTC will set.

DTC B2203 will set if RDCM detects a low voltage level (short to ground) at right window down switch input circuit. This condition must exist for more than 20 seconds. DTC B2203 will store as a history code in RDCM memory. No driver warning will be displayed.

Under all fault conditions, DTC B2203 will clear automatically when RDCM no longer detects a low voltage level (short to ground) at right window down switch input circuit for longer than 20 seconds. Current and history DTCs can be cleared using scan tool or IPC clearing DTCs feature.

Testing

1. Using scan tool, select RDCM input display and monitor driver window status. If scan tool displays passenger window UP status as ACTIVE, go to next step. If scan tool does not display passenger window UP status as ACTIVE, go to step 6).
2. Disconnect right door window switch. Using scan tool, select RDCM input display and monitor passenger side window switch status. If scan tool display shows passenger window UP status as ACTIVE, go to next step. If scan tool display shows passenger window UP status as INACTIVE, go to step 4).
3. Check for short to ground in Light Blue wire between right door window switch and RDCM. Repair as necessary. Then go to step 8). If circuit is okay, go to step 5).
4. Replace right door window switch assembly. Go to step 8).
5. Replace RDCM. Go to step 8).
6. Check right door window switch for intermittent malfunction. See DIAGNOSTIC AIDS. If problem is found and repaired, go to step 8). If no problem is found, go to next step.
7. Turn ignition switch to OFF position. Reconnect or install any connectors or components that were disconnected or removed. Clear any DTCs. See **CLEARING DIAGNOSTIC TROUBLE CODES (DTCs)** . Wait 20 seconds. Check for DTCs. If DTC B2202 sets as history again, go to step 5). If DTC B2203 does not reset, system is okay.
8. Turn ignition switch to OFF position. Reconnect or install any connectors or components that were disconnected or removed. Turn ignition switch to ON position. Clear any DTCs. See **CLEARING DIAGNOSTIC TROUBLE CODES (DTCs)** . Recheck system operation.

1998 Chevrolet Corvette

POWER WINDOWS 1997-98 ACCESSORIES & EQUIPMENT General Motors Corp. - Power Windows

Diagnostic Aids

Following conditions may cause an intermittent malfunction:

- Intermittent short to ground in right window switch UP input circuit (Light Blue wire).
- Right window UP switch is shorted to ground internally or is sticking.
- Right window down switch was depressed for longer than 20 seconds.
- If Light Blue wire is shorted to ground or right window UP switch is stuck closed, right window will remain up at all times.
- Using scan tool, select RDCM inputs and monitor passenger window up switch status. If scan tool displays ACTIVE, disconnect right window switch. If status did not change, check Light Blue wire for short to ground.

DTC B2204: LEFT WINDOW DOWN SWITCH FAULT (LDCM)

Circuit Description

Left door switch circuit provides input to left door control module (LDCM) when left window switch is depressed to UP or DOWN position. This input allows LDCM to detect a left window up or down request. LDCM provides both power and ground to window switches. When left window switch is depressed to UP or DOWN position, ground is supplied through left window switch to left window up or down switch input is pulled low. When LDCM detects low voltage on left window up or down switch input, LDCM will command left window up or down. When switch is released, LDCM will command left window to stop (window express down feature down not activated). LDCM monitors both left window input circuits and determines how long ground had been applied. If ground is applied for longer than expected, a malfunction is present and a DTC will set.

DTC B2204 will set if LDCM detects a low voltage level (short to ground) at left window down switch input circuit. This condition must exist for more than 20 seconds. DTC B2204 will store as a history code in LDCM memory. No driver warning will be displayed.

Under all fault conditions, DTC B2204 will clear automatically when LDCM no longer detects a low voltage level (short to ground) at left window down switch input circuit for longer than 20 seconds. Current and history DTCs can be cleared using scan tool or IPC clearing DTCs feature.

Testing

1. Using scan tool, select LDCM input display and monitor driver window status. If scan tool displays driver window DOWN status as ACTIVE, go to next step. If scan tool does not display driver window DOWN status as ACTIVE, go to step 6).
2. Disconnect left door window switch. Using scan tool, select LDCM input display and monitor driver side window switch status. If scan tool display shows driver window DOWN switch as ACTIVE, go to next step. If scan tool display shows driver window

1998 Chevrolet Corvette

POWER WINDOWS 1997-98 ACCESSORIES & EQUIPMENT General Motors Corp. - Power Windows

- DOWN switch as INACTIVE, go to step 4).
3. Check for short to ground in Gray wire between left door window switch and LDCM. Repair as necessary. Then go to step 8). If circuit is okay, go to step 5).
 4. Replace left door window switch assembly. Go to step 8).
 5. Replace LDCM. Go to step 8).
 6. Check left door window switch for intermittent malfunction. See **DIAGNOSTIC AIDS**. If problem is found and repaired, go to step 8). If no problem is found, go to next step.
 7. Turn ignition switch to OFF position. Reconnect or install any connectors or components that were disconnected or removed. Clear any DTCs. See **CLEARING DIAGNOSTIC TROUBLE CODES (DTCs)** . Wait 20 seconds. Check for DTCs. If DTC B2203 sets as history again, go to step 5). If DTC B2204 does not reset, system is okay.
 8. Turn ignition switch to OFF position. Reconnect or install any connectors or components that were disconnected or removed. Turn ignition switch to ON position. Clear any DTCs. See procedures in **CLEARING DIAGNOSTIC TROUBLE CODES (DTCs)** . Recheck system operation.

Diagnostic Aids

Following conditions may cause an intermittent malfunction:

- Intermittent short to ground in left window down switch input circuit (Gray wire).
- Left window down switch is shorted to ground internally or is sticking.
- Left window down switch was depressed for longer than 20 seconds.
- If Gray wire is shorted to ground or left window down switch is stuck closed, left window will remain down at all times.
- Using scan tool, select LDCM inputs and monitor driver window down switch status. If scan tool displays ACTIVE, disconnect left window switch. If status did not change, check Gray wire for short to ground.

DTC B2205: RIGHT WINDOW DOWN SWITCH FAULT (RDCM)

Circuit Description

Right door switch circuit provides input to right door control module (RDCM) when right window switch is depressed to UP or DOWN position. This input allows RDCM to detect a right window up or down request. RDCM provides both power and ground to window switches. When right window switch is depressed to UP or DOWN position, ground is supplied through right window switch to left window up or down switch input is pulled low. When RDCM detects low voltage on right window up or down switch input, RDCM will command right window up or down. When switch is released, RDCM will command right window to stop (window express down feature down not activated). RDCM monitors both left window input circuits and determines how long ground had been applied. If ground is

1998 Chevrolet Corvette

POWER WINDOWS 1997-98 ACCESSORIES & EQUIPMENT General Motors Corp. - Power Windows

applied for longer than expected, a malfunction is present and a DTC will set.

DTC B2205 will set if RDCM detects a low voltage level (short to ground) at right window down switch input circuit. This condition must exist for more than 20 seconds. DTC B2205 will store as a history code in RDCM memory. No driver warning will be displayed.

Under all fault conditions, DTC B2205 will clear automatically when RDCM no longer detects a low voltage level (short to ground) at right window down switch input circuit for longer than 20 seconds. Current and history DTCs can be cleared using scan tool or IPC clearing DTC's feature.

Testing

1. Using scan tool, select RDCM input display and monitor driver window status. If scan tool displays passenger window DOWN status as ACTIVE, go to next step. If scan tool does not display passenger window DOWN status as ACTIVE, go to step 6).
2. Disconnect right door window switch. Using scan tool, select RDCM input display and monitor passenger side window switch status. If scan tool display shows passenger window DOWN switch as ACTIVE, go to next step. If scan tool display shows passenger window DOWN switch as INACTIVE, go to step 4).
3. Check for short to ground in Tan wire between right door window switch and RDCM. Repair as necessary. After repair go to step 8). If circuit is okay, go to step 5).
4. Replace right door window switch assembly. Go to step 8).
5. Replace RDCM. Go to step 8).
6. Check right door window switch for intermittent malfunction. See **DIAGNOSTIC AIDS**. If problem is found and repaired, go to step 8). If no problem is found, go to next step.
7. Turn ignition switch to OFF position. Reconnect or install any connectors or components that were disconnected or removed. Clear any DTCs. See **CLEARING DIAGNOSTIC TROUBLE CODES (DTCS)** . Wait 20 seconds. Check for DTCs. If DTC B2205 sets as history again, go to step 5). If DTC B2205 does not reset, system is okay.
8. Turn ignition switch to OFF position. Reconnect or install any connectors or components that were disconnected or removed. Turn ignition switch to ON position. Clear any DTCs. See **CLEARING DIAGNOSTIC TROUBLE CODES (DTCS)** . Recheck system operation.

Diagnostic Aids

Following conditions may cause an intermittent malfunction:

- Intermittent short to ground in right window down switch input circuit (Tan wire).
- Right window down switch is shorted to ground internally or is sticking.

1998 Chevrolet Corvette

POWER WINDOWS 1997-98 ACCESSORIES & EQUIPMENT General Motors Corp. - Power Windows

- Right window down switch was depressed for longer than 20 seconds.
- If Tan wire is shorted to ground or left window down switch is stuck closed, left window will remain down at all times.
- Using scan tool, select LDCM inputs and monitor driver window down switch status. If scan tool displays ACTIVE, disconnect left window switch. If status did not change, check Tan wire for short to ground.

DTC B2206: RIGHT WINDOW UP SWITCH FAULT (LDCM)

Circuit Description

Left door switch circuit provides input to left door control module (LDCM) when left window switch is depressed to UP or DOWN position. This input allows LDCM to detect a right window up or down request. LDCM provides both power and ground to window switches. When left door, right window switch is depressed to UP or DOWN position, ground is supplied through right window switch to right window up or down switch input is pulled low. When LDCM detects low voltage on right window up or down switch input, LDCM will send a message over serial data line to RDCM to command right window up or down direction. When switch is released, LDCM will send a second message to RDCM to command right window to stop (window express down feature down not activated). LDCM monitors both left window input circuits and determines how long ground had been applied. If ground is applied for longer than expected, a malfunction is present and a DTC will set.

DTC B2206 will set if LDCM detects a low voltage level (short to ground) at right window up switch input circuit. This condition must exist for more than 20 seconds. DTC B2206 will store as a history code in RDCM memory. No driver warning will be displayed.

Under all fault conditions, DTC B2206 will clear automatically when LDCM no longer detects a low voltage level (short to ground) at right window up switch input circuit for longer than 20 seconds. Current and history DTCs can be cleared using scan tool or IPC clearing DTCs feature.

Testing

1. Using scan tool, select LDCM input display and monitor passenger window status. If scan tool displays passenger window UP status as ACTIVE, go to next step. If scan tool does not display passenger window UP status as ACTIVE, go to step 6).
2. Disconnect right door window switch. Using scan tool, select LDCM input display and monitor passenger side window switch status. If scan tool display shows passenger window switch UP as ACTIVE, go to next step. If scan tool display shows passenger window switch DOWN as INACTIVE, go to step 4).
3. Check for short to ground in Light Blue wire between left door window switch and LDCM. Repair as necessary. Then go to step 8). If circuit is okay, go to step 5).
4. Replace left door window switch assembly. Go to step 8).

1998 Chevrolet Corvette

POWER WINDOWS 1997-98 ACCESSORIES & EQUIPMENT General Motors Corp. - Power Windows

5. Replace LDCM. Go to step 8).
6. Check left door window switch passenger window up circuit for intermittent malfunction. See DIAGNOSTIC AIDS. If problem is found and repaired, go to step 8). If no problem is found, go to next step.
7. Turn ignition switch to OFF position. Reconnect or install any connectors or components that were disconnected or removed. Clear any DTCs. See **CLEARING DIAGNOSTIC TROUBLE CODES (DTCs)** . Wait 20 seconds. Check for DTCs. If DTC B2206 sets as history again, go to step 5). If DTC B2206 does not reset, system is okay.
8. Turn ignition switch to OFF position. Reconnect or install any connectors or components that were disconnected or removed. Turn ignition switch to ON position. Clear any DTCs. See procedures in **CLEARING DIAGNOSTIC TROUBLE CODES (DTCs)** . Recheck system operation.

Diagnostic Aids

Following conditions may cause an intermittent malfunction:

- Intermittent short to ground in left window switch passenger window up input circuit (Light Blue wire).
- Right window up switch is shorted to ground internally or is sticking.
- Left window switch passenger window UP switch was depressed for longer than 20 seconds.
- If Light Blue wire is shorted to ground or left window switch passenger window UP switch is stuck closed, right window will remain up at all times.
- Using scan tool, select LDCM inputs and monitor passenger window up switch status. If scan tool displays ACTIVE, disconnect right window switch. If status did not change to INACTIVE, check Light Blue wire for short to ground.

DTC B2208: RIGHT WINDOW DOWN SWITCH FAULT (LDCM)

Circuit Description

Left door switch circuit provides input to left door control module (LDCM) when left window switch is depressed to UP or DOWN position. This input allows LDCM to detect a right window up or down request. LDCM provides both power and ground to window switches. When left window switch is depressed to UP or DOWN position, ground is supplied through right window switch to right window up or down switch input is pulled low. When LDCM detects low voltage on right window up or down switch input, LDCM will send a message over serial data line to RDCM to command right window in UP or DOWN direction. When switch is released, LDCM will send a second message to RDCM to command right window to stop (window express down feature down not activated). LDCM monitors both left window input circuits and determines how long ground had been applied.

1998 Chevrolet Corvette

POWER WINDOWS 1997-98 ACCESSORIES & EQUIPMENT General Motors Corp. - Power Windows

If ground is applied for longer than expected, a malfunction is present and a DTC will set.

DTC B2208 will set if LDCM detects a low voltage level (short to ground) at right window up switch input circuit. This condition must exist for more than 20 seconds. DTC B2208 will store as a history code in RDCM memory. No driver warning will be displayed.

Under all fault conditions, DTC B2208 will clear automatically when LDCM no longer detects a low voltage level (short to ground) at right window up switch input circuit for longer than 20 seconds. Current and history DTCs can be cleared using scan tool or IPC clearing DTCs feature.

Testing

1. Using scan tool, select LDCM input display and monitor passenger window status. If scan tool displays passenger window DOWN status as ACTIVE, go to next step. If scan tool does not display passenger window DOWN status as ACTIVE, go to step 6).
2. Disconnect right door window switch. Using scan tool, select LDCM input display and monitor passenger side window switch status. If scan tool display shows passenger window switch DOWN status as ACTIVE, go to next step. If scan tool display shows passenger window switch DOWN status as INACTIVE, go to step 4).
3. Check for short to ground in Tan wire between left door window switch and LDCM. Repair as necessary. Then go to step 8). If circuit is okay, go to step 5).
4. Replace left door window switch assembly. Go to step 8).
5. Replace LDCM. Go to step 8).
6. Check left door window switch passenger window up circuit for intermittent malfunction. See DIAGNOSTIC AIDS. If problem is found and repaired, go to step 8). If no problem is found, go to next step.
7. Turn ignition switch to OFF position. Reconnect or install any connectors or components that were disconnected or removed. Clear any DTCs. See **CLEARING DIAGNOSTIC TROUBLE CODES (DTCS)** . Wait 20 seconds. Check for DTCs. If DTC B2208 sets as history again, go to step 5). If DTC B2208 does not reset, system is okay.
8. Turn ignition switch to OFF position. Reconnect or install any connectors or components that were disconnected or removed. Turn ignition switch to ON position. Clear any DTCs. See procedures in **CLEARING DIAGNOSTIC TROUBLE CODES (DTCS)** . Recheck system operation.

Diagnostic Aids

Following conditions may cause an intermittent malfunction:

- Intermittent short to ground in left window switch passenger window down input circuit (Tan wire).

1998 Chevrolet Corvette

POWER WINDOWS 1997-98 ACCESSORIES & EQUIPMENT General Motors Corp. - Power Windows

- Right window down switch is shorted to ground internally or is sticking.
- Left window switch passenger window UP switch was depressed for longer than 20 seconds.
- If Tan wire is shorted to ground or left window switch passenger window DOWN switch is stuck closed, right window will remain down at all times.
- Using scan tool, select LDCM inputs and monitor passenger window down switch status. If scan tool displays ACTIVE, disconnect right window switch. If status did not change to INACTIVE, check Tan wire for short to ground.

DTC B2274: WINDOW MOTOR FAULT (LDCM)

Circuit Description

Left door control module (LDCM) provides left motor control output functions. This output control allows LDCM to command left power window up or down. Left door switch circuit provides an input to LDCM when window switch is depressed to UP or DOWN position. When LDCM detects an active window command from left window switch, DCM will command left window motor in appropriate direction. LDCM applies ground or voltage to appropriate circuit (Dark Blue or Brown wire) depending on desired direction. LDCM monitors amount of current draw on left window motor circuit. If current draw is not within acceptable range, a malfunction is present and DTC will set.

DTC B2274 will set if LDCM detects a short to voltage condition in left window motor control circuit when left window motor is not activated. This condition must exist for more than 20 seconds. DTC B2274 will store as a history code in LDCM memory. No driver warning will be displayed.

Under all fault conditions, DTC B2274 will clear automatically when LDCM no longer detects a short to voltage in left window motor control circuit for longer than 120 milliseconds. Current and history DTCs can be cleared using scan tool or IPC clearing DTCs feature.

Testing

1. Turn ignition switch to OFF position. Disconnect left window motor connector. Turn ignition switch to RUN position. Using DVOM, check voltage between left motor harness connector terminals "A" (Dark Blue wire) and "B" (Brown wire). Operate left window up and down. If 10-14 volts exists in both positions, go to step 5). If 10-14 volts does not exist in both positions, go to next step.
2. Check for open or short to ground or voltage in Dark Blue or Brown wire between left window motor and LDCM. If problem is found, repair as necessary, go to step 6). If no problem was found, go to step 5).
3. Replace left window motor. After repair, go to step 6).
4. Replace LDCM. Go to step 6).

1998 Chevrolet Corvette

POWER WINDOWS 1997-98 ACCESSORIES & EQUIPMENT General Motors Corp. - Power Windows

5. Check left door window motor circuit for intermittent malfunction. See DIAGNOSTIC AIDS. If problem is found and repaired, go to next step. If no problem is found, go to next step.
6. Turn ignition switch to OFF position. Reconnect or install any connectors or components that were disconnected or removed. Turn ignition switch to ON position. Clear any DTCs. See **CLEARING DIAGNOSTIC TROUBLE CODES (DTCs)** . Recheck system operation.

Diagnostic Aids

Following conditions may cause an intermittent malfunction:

- Intermittent short to ground in left window motor circuits (Dark Blue or Brown wire).
- Left window motor is shorted to ground internally.
- Left window motor circuit is shorted to voltage, allowing operation in one direction only in certain directions depending on circuit affected.
- Using scan tool, select LDCM inputs and monitor window motor load while operating left window up and down. If scan tool displays motor load a zero, check left window motor circuit for opens.

DTC B2275: WINDOW MOTOR FAULT (RDCM)

Circuit Description

Right door control module (RDCM) provides right motor control output functions. This output control allows RDCM to command right power window up or down. Right door switch circuit provides an input to RDCM when window switch is depressed to UP or DOWN position. When RDCM detects an active window command from either right window switch or window command on serial data line from LDCM, RDCM will command left window motor in appropriate direction. RDCM applies ground or voltage to appropriate circuit (Dark Blue or Brown wire) depending on desired direction. RDCM monitors amount of current draw on left window motor circuit. If current draw is not within the acceptable range, a malfunction is present and DTC B2275 will set.

DTC B2275 will set if RDCM detects a short to voltage condition in right window motor control circuit when right window motor is not activated. This condition must exist for more than 20 seconds. DTC B2275 will store as a history code in RDCM memory. No driver warning will be displayed.

Under all fault conditions, DTC B2275 will clear automatically when RDCM no longer detects a short to voltage in right window motor control circuit for longer than 120 milliseconds. Current and history DTCs can be cleared using scan tool or IPC clearing DTCs feature.

Testing

1998 Chevrolet Corvette

POWER WINDOWS 1997-98 ACCESSORIES & EQUIPMENT General Motors Corp. - Power Windows

1. Turn ignition switch to OFF position. Disconnect right window motor connector. Turn ignition switch to RUN position. Using DVOM, check voltage between right motor harness connector terminals "A" (Dark Blue wire) and "B" (Brown wire). Operate right window UP and DOWN. If 10-14 volts is measured in both positions, go to step 5). If 10-14 volts does not exist in both positions, go to next step.
2. Check for open or short to ground or voltage in Dark Blue or Brown wire between right window motor and RDCM. If problem is found, repair as necessary, go to step 6). If no problem was found, go to step 5).
3. Replace right window motor. After repair, go to step 6).
4. Replace RDCM. Go to step 6).
5. Check right door window motor circuit for intermittent malfunction. See DIAGNOSTIC AIDS. If problem is found and repaired, go to next step. If no problem is found, go to next step.
6. Turn ignition switch to OFF position. Reconnect or install any connectors or components that were disconnected or removed. Turn ignition switch to ON position. Clear any DTCs. See **CLEARING DIAGNOSTIC TROUBLE CODES (DTCs)** . Recheck system operation.

Diagnostic Aids

Following conditions may cause an intermittent malfunction:

- Intermittent short to ground in right window motor circuits (Dark Blue or Brown wire).
- Right window motor is shorted to ground internally.
- Right window motor circuit is shorted to voltage, allowing operation in one direction only in certain directions depending on circuit affected.
- Using scan tool, select RDCM inputs and monitor window motor load while operating right window up and down. If scan tool displays motor load a zero, check right window motor circuit for opens.

DTC B2282: BATTERY NO. 1 FAULT (LDCM)

Circuit Description

LDCM has two main power feeds (high and low), and one main ground. Low power feed (battery No. 1) is used to provide power for LDCM logic and internal driver operation. High power feed (battery No. 2) is used to provide power for systems that draw higher amounts of current (motors, light, etc.). For most functions, LDCM will operate properly when vehicle system voltage is 9.0-16.0 volts. LDCM also monitors voltage level at battery No. 1 and battery No. 2 and can determine if voltage level received is out of range. If voltage is out of range in either circuit, a malfunction is present and DTC will set.

DTC B2282 will set if LDCM detects battery No. 1 voltage range less than 8.5 volts or

1998 Chevrolet Corvette

POWER WINDOWS 1997-98 ACCESSORIES & EQUIPMENT General Motors Corp. - Power Windows

greater than 16.3 volts. This condition must exist for 2 seconds. DTC B2282 will store as a history code in LDCM memory. No driver warning will be displayed.

Under all fault conditions, DTC B2282 will clear automatically when LDCM detects battery No. 1 voltage range 8.5-16.3 volts for longer than 2 seconds. Current and history DTCs can be cleared using scan tool or IPC clearing DTCs feature.

Testing

1. Verify vehicle starting/charging system is functioning properly. See appropriate **STARTING & CHARGING SYSTEMS** article. Repair as necessary. If starting and charging systems are functioning properly, go to next step.
2. Using scan tool, select LDCM data display and monitor battery No. 1 data. If scan tool display shows 8.5-16.3 volts, go to step 4). If scan tool display does not show 8.5-16.3 volts, go to next step.
3. Turn ignition switch to OFF position. Disconnect LDCM Red, 26-pin connector C1. Turn ignition switch to RUN position. Check voltage between LDCM harness connector C1, terminal No. 1 (Orange wire) and ground. If 8.5-16.3 volts exists, go to step 7). If 8.5-16.3 volts does not exist, go to step 5).
4. Using scan tool, select LDCM DTC display. Check for DTC B2272, B2274, B2276 or B2278. If any of these DTCs are stored as history, go to applicable DTC test. If no DTCs are stored in history, go to step 8).
5. Repair open or short to ground in instrument panel electrical center or Orange wire between instrument panel electrical center and LDCM. After repair, go to step 9).
6. Replace LDCM. Go to step 9).
7. Problem is intermittent, check battery No. 1 circuit for malfunction. See **DIAGNOSTIC AIDS**. If a problem was found. Repair as necessary and go to step 9). If no problem was found, go to next step.
8. Turn ignition switch to OFF position. Reconnect or install any connectors or components that were disconnected or removed. Turn ignition switch to RUN position. Clear any DTCs. See procedures in **CLEARING DIAGNOSTIC TROUBLE CODES (DTCS)** . Wait 2 seconds. If DTC B2282 resets, go to step 7). If DTC B2282 does not reset, system is okay.
9. Turn ignition switch to OFF position. Reconnect or install any connectors or components that were disconnected or removed. Turn ignition switch to ON position. Clear any DTCs. See **CLEARING DIAGNOSTIC TROUBLE CODES (DTCS)** . Recheck system operation.

Diagnostic Aids

Following conditions may cause an intermittent malfunction:

- Intermittent open or short to ground in battery No. 1 circuit (Orange wire).

1998 Chevrolet Corvette

POWER WINDOWS 1997-98 ACCESSORIES & EQUIPMENT General Motors Corp. - Power Windows

- Battery voltage is not within range (8.5-16.3 volts).
- Charging system malfunction.
- Using scan tool, select LDCM data display and monitor battery No. 1 voltage while test driving vehicle and operating different devices (windows, door locks, etc.). This can determine if battery No. 1 voltage is affected by these devices and can help duplicate malfunction.

DTC B2283: BATTERY NO. 1 FAULT (RDCM)

Circuit Description

RDCM has 2 main power feeds (high and low), and one main ground. Low power feed (battery No. 1) is used to provide power for RDCM logic and internal driver operation. High power feed (battery No. 2) is used to provide power for systems that draw higher amounts of current (motors, light, etc.). For most functions, RDCM will operate properly when vehicle system voltage is 9.0-16.0 volts. RDCM also monitors voltage level at battery No. 1 and battery No. 2 and can determine if voltage level received is out of range. If voltage is out of range in either circuit, a malfunction is present and DTC will set.

DTC B2283 will set if RDCM detects battery No. 1 voltage range less than 8.5 volts or greater than 16.3 volts. This condition must exist for 2 seconds. DTC B2283 will store as a history code in RDCM memory. No driver warning will be displayed.

Under all fault conditions, DTC B2283 will clear automatically when LDCM detects battery No. 1 voltage range is 8.5-16.3 volts for longer than 2 seconds. Current and history DTCs can be cleared using scan tool or IPC clearing DTCs feature.

Testing

1. Verify vehicle starting/charging system is functioning properly. STARTER article or GENERATOR & REGULATOR article in ELECTRICAL section. Repair as necessary. If starting and charging systems are functioning properly, go to next step.
2. Using scan tool, select RDCM data display and monitor battery No. 1 data. If scan tool display shows 8.5-16.3 volts, go to step 4). If scan tool display does not show 8.5-16.3 volts, go to next step.
3. Turn ignition switch to OFF position. Disconnect RDCM Red, 26-pin connector C1. Turn ignition switch to RUN position. Check voltage between RDCM harness connector C1 terminal No. 1 (Orange wire) and ground. If 8.5-16.3 volts exists, go to step 7). If 8.5-16.3 volts does not exist, go to step 5).
4. Using scan tool, select RDCM DTC display. Check for DTC B2273, B2275, B2277 or B2279. If any of these DTCs are stored as history, go to applicable DTC test. If no DTCs are stored in history, go to step 8).
5. Repair open or short to ground in instrument panel electrical center or Orange wire between instrument panel electrical center and RDCM. After repair, go to step 9).

1998 Chevrolet Corvette

POWER WINDOWS 1997-98 ACCESSORIES & EQUIPMENT General Motors Corp. - Power Windows

6. Replace RDCM. Go to step 9).
7. Problem is intermittent, check battery No. 1 circuit for malfunction. See DIAGNOSTIC AIDS. If a problem was found and repaired, go to step 9). If no problem was found, go to next step.
8. Turn ignition switch to OFF position. Reconnect or install any connectors or components that were disconnected or removed. Turn ignition switch to RUN position. Clear any DTCs. See procedures in **CLEARING DIAGNOSTIC TROUBLE CODES (DTCS)** . Wait 2 seconds. If DTC B2283 resets, go to step 7). If DTC B2283 does not reset, system is okay.
9. Turn ignition switch to OFF position. Reconnect or install any connectors or components that were disconnected or removed. Turn ignition switch to ON position. Clear any DTCs. See **CLEARING DIAGNOSTIC TROUBLE CODES (DTCS)** . Recheck system operation.

Diagnostic Aids

Following conditions may cause an intermittent malfunction:

- Intermittent open or short to ground in battery No. 1 circuit (Orange wire).
- Battery voltage is not within range (8.5-16.3 volts).
- Charging system malfunction.
- Using scan tool, select RDCM data display and monitor battery No. 1 voltage while test driving vehicle and operating different devices (windows, door locks, etc.). This can determine if battery No. 1 voltage is affected by these devices and can help duplicate malfunction.

DTC B2284: BATTERY NO. 2 FAULT (LDCM)

Circuit Description

LDCM has two main power feeds (high and low), and one main ground. Low power feed (battery No. 1) is used to provide power for LDCM logic and internal driver operation. High power feed (battery No. 2) is used to provide power for systems that draw higher amounts of current (motors, light, etc.). For most functions, LDCM will operate properly when vehicle system voltage is 9.0-16.0 volts. LDCM also monitors voltage level at battery No. 1 and battery No. 2 and can determine if voltage level received is out of range. If voltage is out of range in either circuit, a malfunction is present and DTC will set.

DTC B2284 will set if LDCM detects battery No. 2 voltage range under 8.5 volts or over 16.3 volts. This condition must exist for 2 seconds. DTC B2284 will store as a history code in LDCM memory. No driver warning will be displayed.

Under all fault conditions, DTC B2284 will clear automatically when LDCM detects battery No. 2 voltage range is 8.5-16.3 volts for longer than 2 seconds. Current and history DTCs

can be cleared using scan tool or IPC clearing DTCs feature.

Testing

1. Verify vehicle starting/charging system is functioning properly. See STARTER article or GENERATOR & REGULATOR article in ELECTRICAL section. Repair as necessary. If starting and charging systems are functioning properly, go to next step.
2. Using scan tool, select LDCM data display and monitor battery No. 2 data. If scan tool display shows 8.5-16.3 volts, go to step 4). If scan tool display does not show 8.5-16.3 volts, go to next step.
3. Turn ignition switch to OFF position. Disconnect LDCM Black, 6-pin connector C3. Turn ignition switch to RUN position. Check voltage between LDCM harness connector C3 terminal "A" (Orange wire) and ground. See **Fig. 3** . If 8.5-16.3 volts exists, go to step 7). If 8.5-16.3 volts does not exist, go to step 5).
4. Using scan tool, select LDCM DTC display. Check for DTC B2272, B2274, B2276 or B2278. If any of these DTCs are stored as history, go to applicable DTC test. If no DTCs are stored in history, go to step 8).
5. Repair open or short to ground in instrument panel electrical center or Orange wire between instrument panel electrical center and LDCM. After repair, go to step 9).
6. Replace LDCM. Go to step 9).
7. Problem is intermittent, check battery No. 2 circuit for malfunction. See DIAGNOSTIC AIDS. If a problem was found and repaired, go to step 9). If no problem was found, go to next step.
8. Turn ignition switch to OFF position. Reconnect or install any connectors or components that were disconnected or removed. Turn ignition switch to RUN position. Clear any DTCs. See procedures in **CLEARING DIAGNOSTIC TROUBLE CODES (DTCs)** . Wait 2 seconds. If DTC B2284 resets, go to step 7). If DTC B2284 does not reset, system is okay.
9. Turn ignition switch to OFF position. Reconnect or install any connectors or components that were disconnected or removed. Turn ignition switch to ON position. Clear any DTCs. See procedures in **CLEARING DIAGNOSTIC TROUBLE CODES (DTCs)** . Recheck system operation.

Diagnostic Aids

Following conditions may cause an intermittent malfunction:

- Intermittent open or short to ground in battery No. 2 circuit (Orange wire).
- Battery voltage is not within range (8.5-16.3 volts).
- Charging system malfunction.
- Using scan tool, select LDCM data display and monitor battery No. 2 voltage while test driving vehicle and operating different devices (windows, door locks, etc.). This can

determine if battery No. 2 voltage is affected by these devices and can help duplicate malfunction.

DTC B2285: BATTERY NO. 2 FAULT (RDCM)

Circuit Description

RDCM has 2 main power feeds (high and low), and one main ground. Low power feed (battery No. 1) is used to provide power for RDCM logic and internal driver operation. High power feed (battery No. 2) is used to provide power for systems that draw higher amounts of current (motors, light, etc.). For most functions, RDCM will operate properly when vehicle system voltage is 9.0-16.0 volts. RDCM also monitors voltage level at battery No. 1 and battery No. 2 and can determine if voltage level received is out of range. If voltage is out of range in either circuit, a malfunction is present and DTC will set.

DTC B2285 will set if RDCM detects battery No. 1 voltage range less than 8.5 volts or greater than 16.3 volts. This condition must exist for 2 seconds. DTC B2285 will store as a history code in RDCM memory. No driver warning will be displayed.

Under all fault conditions, DTC B2285 will clear automatically when RDCM detects battery No. 2 voltage range is 8.5-16.3 volts for longer than 2 seconds. Current and history DTCs can be cleared using scan tool or IPC clearing DTCs feature.

Testing

1. Verify vehicle starting/charging system is functioning properly. See STARTER article or GENERATOR & REGULATOR article in ELECTRICAL section. Repair as necessary. If starting and charging systems are functioning properly, go to next step.
2. Using scan tool, select RDCM data display and monitor battery No. 2 data. If scan tool display shows 8.5-16.3 volts, go to step 4). If scan tool display does not show 8.5-16.3 volts, go to next step.
3. Turn ignition switch to OFF position. Disconnect RDCM Black, 6-pin connector C3. Turn ignition switch to RUN position. Check voltage between RDCM harness connector C3 terminal "A" (Orange wire) and ground. See **Fig. 3** . If 8.5-16.3 volts exists, go to step 7). If 8.5-16.3 volts does not exist, go to step 5).
4. Using scan tool, select RDCM DTC display. Check for DTC B2273, B2275, B2277 or B2279. If any of these DTCs are stored as history, go to applicable DTC test. If no DTCs are stored in history, go to step 8).
5. Repair open or short to ground in instrument panel electrical center or Orange wire between instrument panel electrical center and RDCM. After repair, go to step 9).
6. Replace RDCM. Go to step 9).
7. Problem is intermittent, check battery No. 2 circuit for malfunction. See Diagnostic Aids. If a problem was found and repaired, go to step 9). If no problem was found, go to next step.

1998 Chevrolet Corvette

POWER WINDOWS 1997-98 ACCESSORIES & EQUIPMENT General Motors Corp. - Power Windows

8. Turn ignition switch to OFF position. Reconnect or install any connectors or components that were disconnected or removed. Turn ignition switch to RUN position. Clear any DTCs. See procedures in **CLEARING DIAGNOSTIC TROUBLE CODES (DTCS)** . Wait 2 seconds. If DTC B2285 resets, go to step 7). If DTC B2285 does not reset, system is okay.
9. Turn ignition switch to OFF position. Reconnect or install any connectors or components that were disconnected or removed. Turn ignition switch to ON position. Clear any DTCs. See **CLEARING DIAGNOSTIC TROUBLE CODES (DTCS)** . Recheck system operation.

Diagnostic Aids

Following conditions may cause an intermittent malfunction:

- Intermittent open or short to ground in battery No. 2 circuit (Orange wire).
- Battery voltage is not within range (8.5-16.3 volts).
- Charging system malfunction.
- Using scan tool, select RDCM data display and monitor battery No. 2 voltage while test driving vehicle and operating different devices (windows, door locks, etc.). This can determine if battery No. 2 voltage is affected by these devices and can help duplicate malfunction.

REMOVAL & INSTALLATION

WINDOW MOTOR

See WINDOW REGULATOR.

WINDOW REGULATOR

NOTE: Window regulator and motor are serviced as an assembly.

WARNING: Disconnect power window switch when working inside door. Express down feature will cause window to drop rapidly, which could cause injury.

Removal & Installation

1. Pull inside door handle to access door handle bezel locking tabs. Insert a screwdriver below bezel. Pry downward while pulling on bezel. Remove bezel.
2. Remove power window switch. See WINDOW SWITCH. Remove 2 screws hidden behind pull handle. Pry door panel clips to remove door trim panel. Remove door panel with speaker grill.

1998 Chevrolet Corvette

POWER WINDOWS 1997-98 ACCESSORIES & EQUIPMENT General Motors Corp. - Power Windows

3. Remove watershield. Remove speaker from door. Remove plugs from window clamp access holes. Reinstall window switch to adjust window height for access to window clamp nuts. Remove window clamp nuts and window from door.
4. Disconnect window motor electrical connector. Remove access plug from under front of door. Place marks on regulator to aid in installation adjustment. Remove nuts from top and bottom of each regulator channel.
5. Remove regulator motor mounting nuts. Remove regulator assembly through door inner opening. To install, adjust regulator jack screws to same position as old regulator. Install nuts to regulator channel studs in following order, upper front, lower front, upper rear then lower rear. Tighten nuts to 89 INCH lbs. (10 mm) To complete installation, reverse removal procedure.

WINDOW SWITCH

Removal & Installation

On passenger side, pry up front edge of switch assembly and slide forward. Disconnect electrical connector. On driver side, pry up rear edge of switch assembly and slide rearward. Disconnect electrical connector. To Install, reverse removal procedure.

WIRING DIAGRAMS

1998 Chevrolet Corvette

POWER WINDOWS 1997-98 ACCESSORIES & EQUIPMENT General Motors Corp. - Power Windows

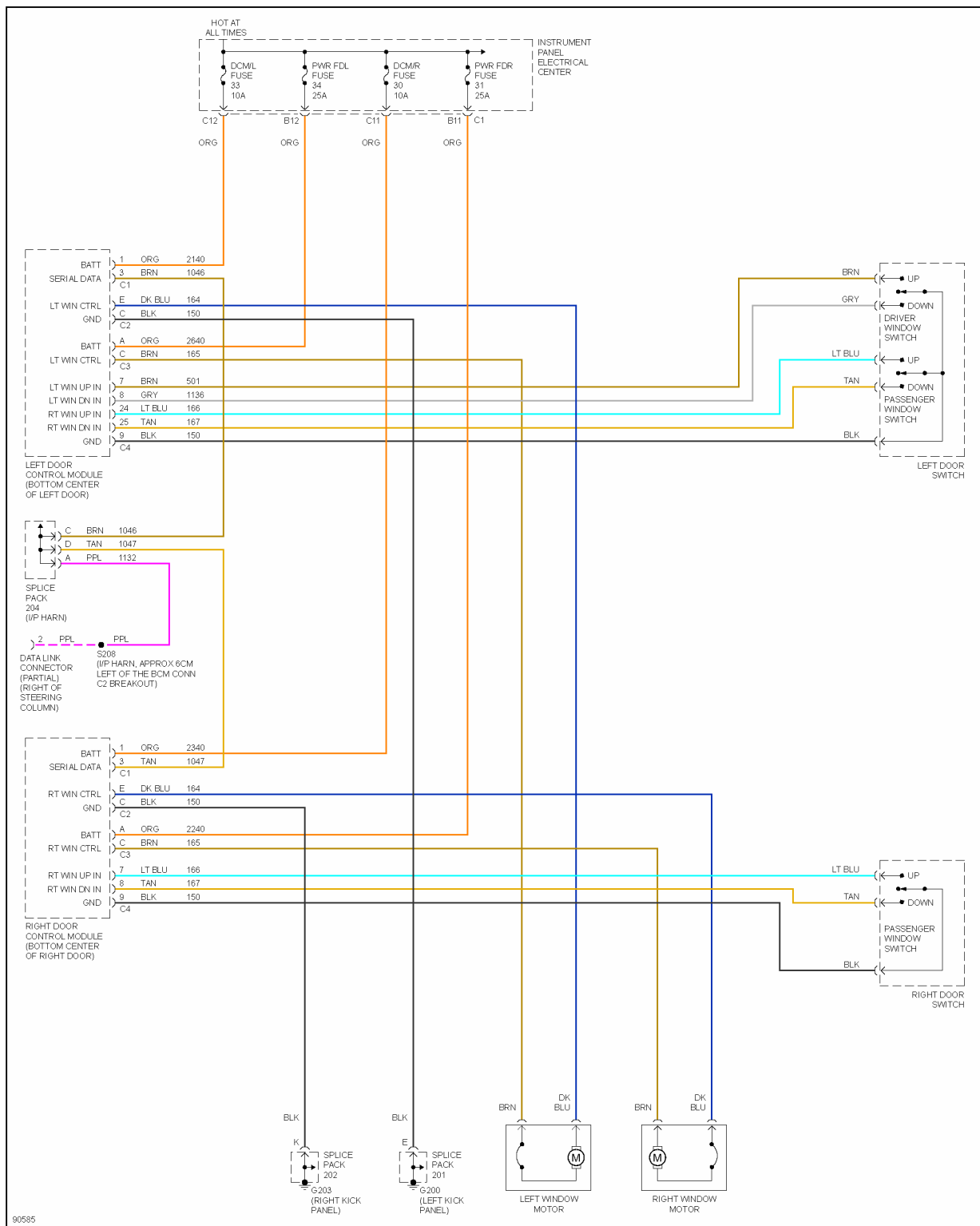

Fig. 4: Power Window System Wiring Diagram (1997)

1998 Chevrolet Corvette

POWER WINDOWS 1997-98 ACCESSORIES & EQUIPMENT General Motors Corp. - Power Windows

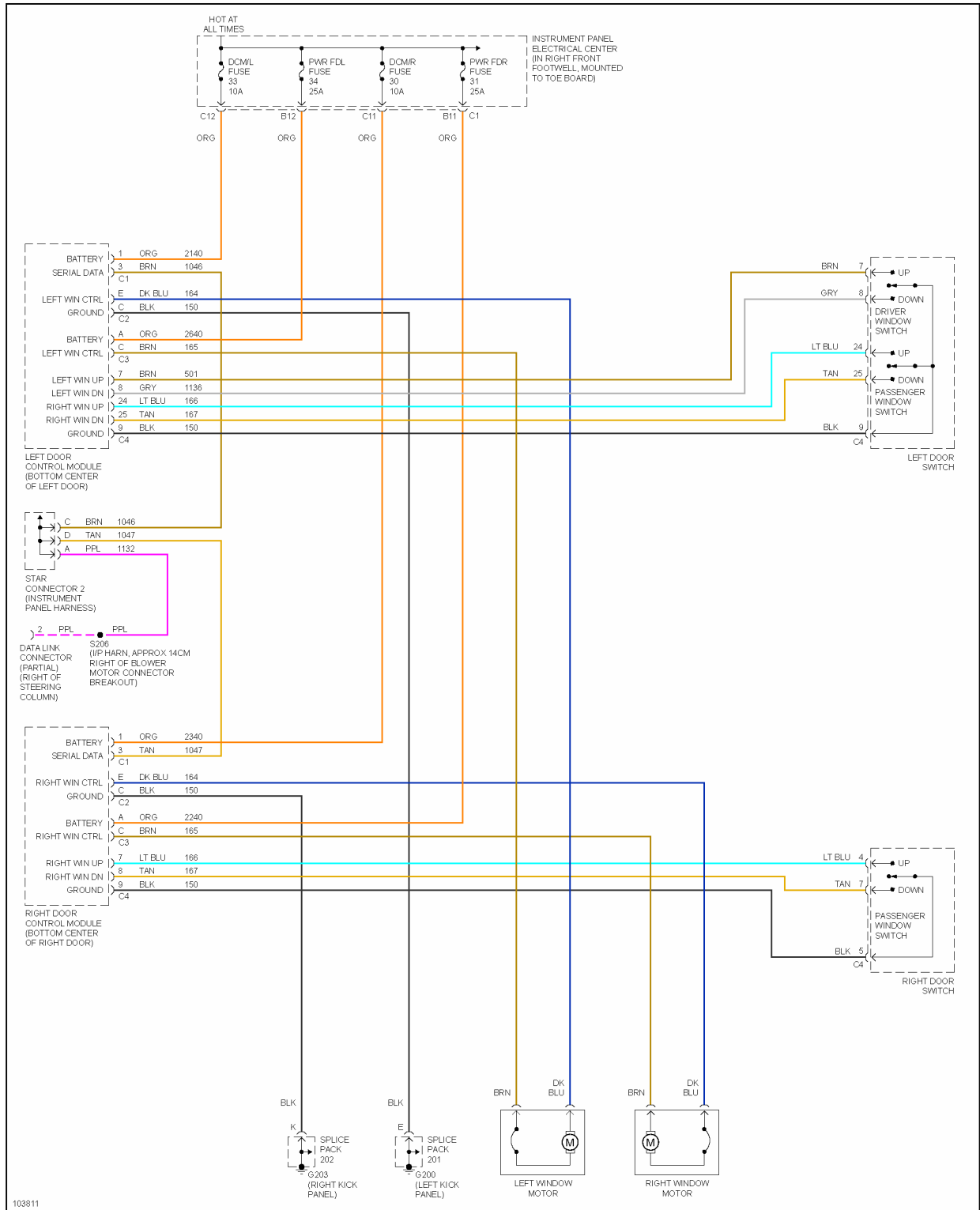
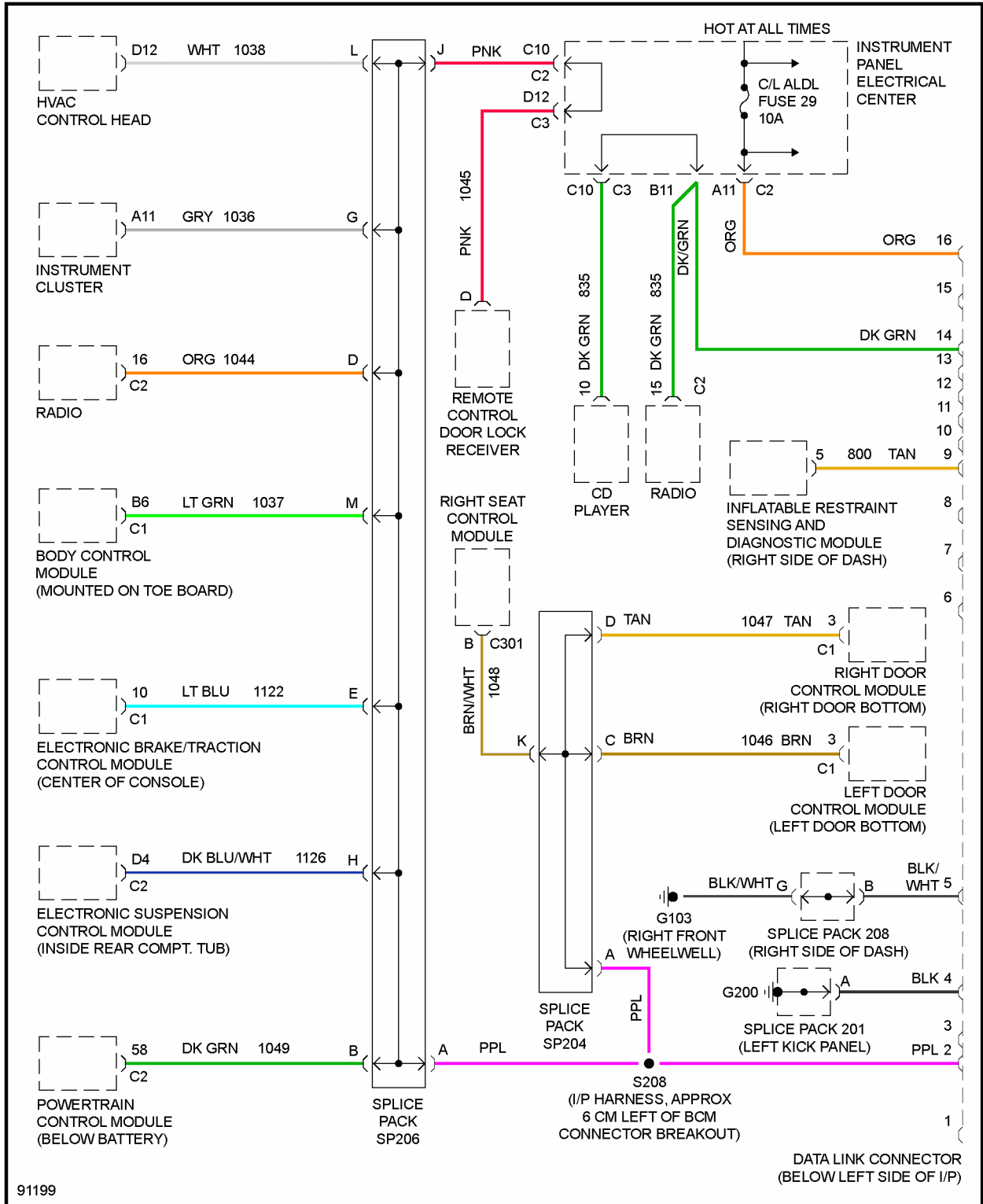

Fig. 5: Power Window System Wiring Diagram (1998)

1998 Chevrolet Corvette

POWER WINDOWS 1997-98 ACCESSORIES & EQUIPMENT General Motors Corp. - Power Windows



91199

Fig. 6: Data Link Connector Wiring Diagram (1997)

1998 Chevrolet Corvette

POWER WINDOWS 1997-98 ACCESSORIES & EQUIPMENT General Motors Corp. - Power Windows

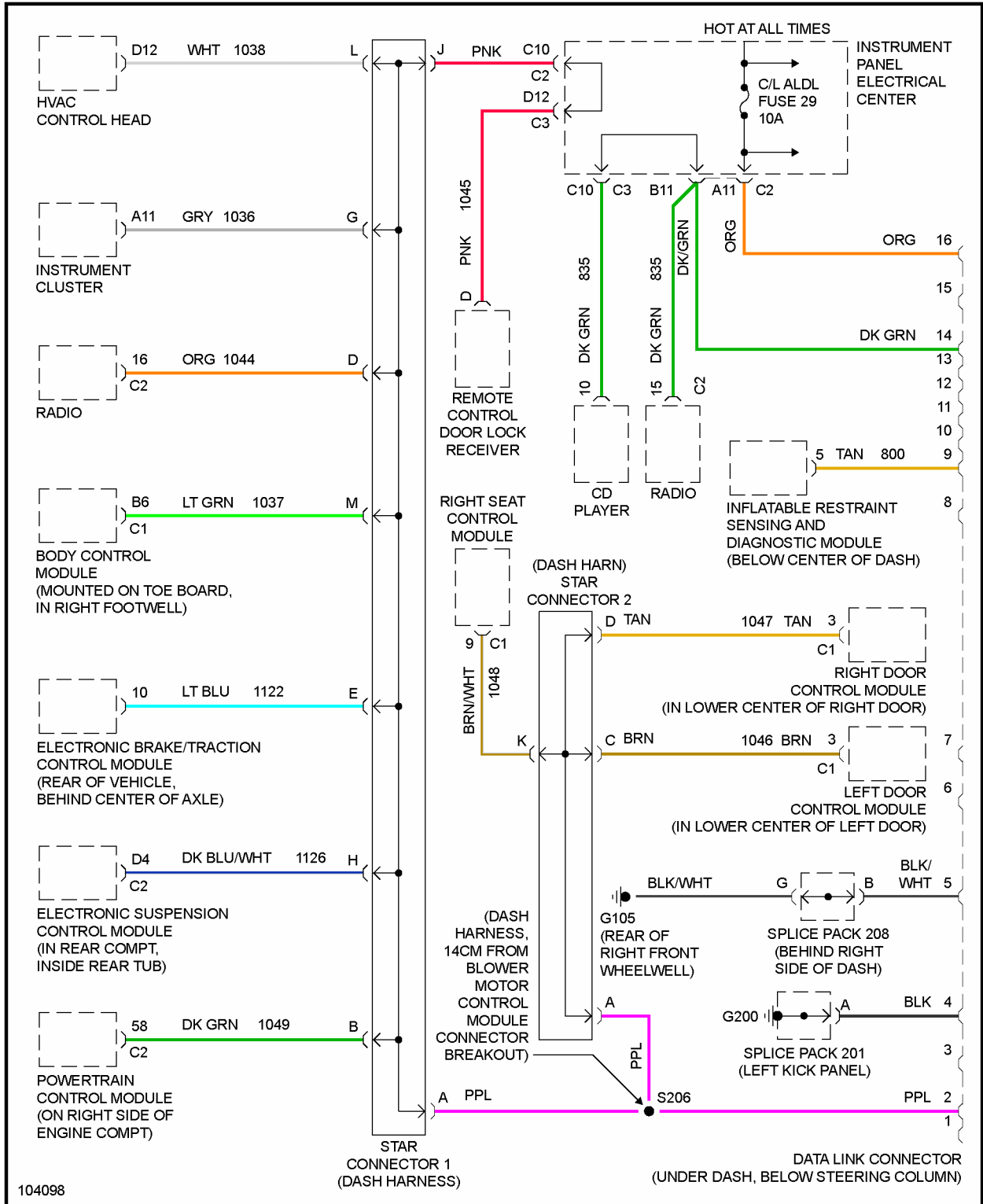

Fig. 7: Data Link Connector Wiring Diagram (1998)